

Introduction

Purpose

This manual provides instructions for usage, installation, and maintenance of the Back Room Communication Module 2 (BRCM2).

Intended Users

This manual is intended for Gilbarco®-trained and certified Authorized Service Contractors (ASCs).

Table of Contents

Topic	Page
Introduction	1
Important Safety Information	5
Consignes de sécurité importantes	7
Federal Communications Commission (FCC) Warning	9
Supplier's Declaration of Conformity (PA0422 series)	9
Supplier's Declaration of Conformity (PA0435 series)	9
Before You Begin	10
Summary of BRCM2 Variants	11
Mounting Requirement and In-Store Wiring	11
General Site Configurations	14
BRCM2 Field Wiring Detail for Pass-Through Mode (PA04222000002B and PA0435200002)	19
BRCM2 Field Wiring Detail and Configuring the PA0422000x022B	20
D-Box Board Jumper Configurations	21
Upgrade existing D-box using PA04222000002x, or PA0435200002	24
RJ-45 Access	27
Networking Considerations	27
BRCM2 Tool	27

Required Tools

The following tools and materials are required for installing BRCM2.x:

- Needle-Nose Pliers
- Wire Strippers
- Phillips® Screwdriver
- Diagonal Cutters
- Wire Nuts
- Tools to Install Conduit

Required Reading



Before performing the installation, read, understand, and follow:

- This manual
- NFPA 30A, The Automotive and Marine Service Station Code
- NFPA 70®, The National Electric Code (NEC®)
- Applicable federal, state, and local codes and regulations

Failure to do so may adversely affect the safe use and operation of the equipment.

Note: To ensure valid warranty, this kit must be installed by a Gilbarco-trained ASC.

Prior to Ordering

- Review “[BRCM2 Field Wiring Detail for Pass-Through Mode \(PA0422200002B and PA0435200002\)](#)” on [page 19](#), which discusses the potential use-cases for the BRCM2. Understand whether you will be using the internal D-box function or your POS system provides the current drive to each dispenser's pump controller. If provided by the POS, pass-through mode is typically used, but [Figure 5](#) on [page 16](#) and [Figure 7](#) on [page 18](#) describe alternate solutions.
- Review “[Summary of BRCM2 Variants](#)” on [page 11](#) to confirm the BRCM2 model that you need to order or to confirm that you have a model that can be used.
- See “[Networking Considerations](#)” on [page 27](#) regarding in-store networking considerations.
- Read “[BRCM2 Tool](#)” on [page 27](#), to be used after installation.

Theory of Operation

The BRCM2 is on the store side of a solution that allows TCP/IP communication between a store and a dispenser over a wire-pair. Because this high-speed communication occurs in a high-frequency band, there are two model types:

- Models that include a Distribution Box (D-Box) to provide the fan-out for a legacy current loop on the same wire-pair.
- Models that rely on external current loops drive and simply add the high-speed signal to those wires.

The wire-pair to the dispensers can be twisted or untwisted. At the dispenser, the high and low frequencies are separated (recovering the original current loop) and the high-speed communication is converted back into Ethernet normal form.

A BRCM2 can support 16 physical connections. If additional dispensers need to be supported, a BRCM2 Expander can be used.

Low Voltage Disconnect Function - NEC 514.11

The BRCM2 is designed to meet the National Electric Code, section 514.11, the low voltage disconnect function. To provide this function, the BRCM2 must be powered by an E-stop disconnect AC source and all field wiring must go through the Field Wiring Board (M14881) or the new D-box board (M16107).

The BRCM2 is further designed to be lockout/tagout capable. This is accomplished with a power switch that is only accessible from the interior and a lockable lid.

Figure 1: Locking Hasp Provision and Lockout/Tagout Power Switch

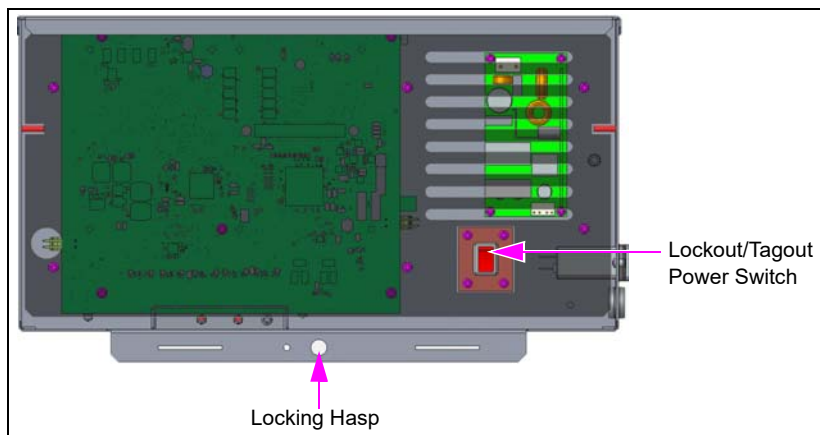

Related Documents

Document Number	Title	GOLD SM Library
MDE-5234	Distribution Box (D-Box) to Verifone® Commander Point of Sale (POS) Adapter Kit (M14671K001) Installation Instructions	M14671K001 installation instructions
MDE-5503	BRCM2 Expander Installation Instructions	Expander

Glossary

Term	Description
FP2	Flexpay™ II: A PCI 2 device, recognizable by the plastic housing on the back of the display, and the Flexpay Control Board having a heat sink.
BRCM1	Back Room Communication Module 1: Introduced with FP2. This is the back-room portion of a DSL-based wire pair solution. Twisted pair wiring to dispenser STRONGLY suggested. NOT COMPATIBLE WITH DCM2/DCM3.
DCM1	Dispenser Communication Module 1: Introduced with FP2. This is the dispenser-side solution for the BRCM1. NOT COMPATIBLE WITH BRCM2.
FP4	Flexpay IV: A PCI 4 or 5 device, recognizable by the square, metal card reader.
BRCM2	Back Room Communication Module 2: Introduced with FP4. Similar in function to BRCM1, although not interchangeable. Can use twisted or untwisted wire.
DCM2 (CCP)	Dispenser Communication Module 2: Introduced with FP4 and is used in non-Omnia dispenser solutions. The DCM2 will optionally include GSOMs, and/or an SSoM. For this document, this includes M14576 and M15341.
DCM3	Dispenser Communication Module 2: Introduced with FP4 and is used in Omnia dispenser solutions. Board # M15724.
BRCM2 Expander	A simplified BRCM2, but without the Ethernet to high-speed conversion. Instead, the high-speed signal from the BRCM2 is routed to the Expander and is further distributed. The Expander also has the options to include the D-box function or not. See Expander MDE for details.
Pass-through mode	This is used for cases where the POS, forecourt controller, or an external D-box (or FCI box) provides current loop drive for each dispenser. In this mode the high-speed signal is added to each of the current loop pairs.

Abbreviations and Acronyms

Term	Description
ASC	Authorized Service Contractor
BRCM	Back Room Communication Module
CCP	Cloud Control Processor
CPR	Cardiopulmonary Resuscitation
CRIND®	Card Reader in Dispenser
COMM	Communication
D-Box	Distribution Box
DCM	Dispenser Communication Module
DEF	Diesel Exhaust Fluid
E-CIM	Enhanced Customer Interface Module
EMV	Europay®, MasterCard®, and Visa®
EPP	Encrypting PIN Pad
ESD	Electrostatic Discharge
FCC	Federal Communications Commission
FCI	Forecourt Communications Interface
GOLD	Gilbarco Online Documentation
HCM	High Speed Communication Module
LAN	Local Area Network
LED	Light Emitting Diode
NEC	National Electrical Code
NFPA	National Fire Protection Association
OSHA	Occupational Safety and Health Administration
PCA	Printed Circuit Assembly
POS	Point of Sale
SCR	Secure Card Reader
SSoM	Secure Systems on Module
STP	Submersible Turbine Pump
TAC	Technical Assistance Center
TCP/IP	Transmission Control Protocol/Internet Protocol
TRIND®	Transmitter/Receiver In Dispenser

Important Safety Information

Notes: 1) Save this Important Safety Information section in a readily accessible location.

2) Although DEF is non-flammable, Diesel is flammable. Therefore, for DEF cabinets that are attached to Diesel dispensers, follow all the notes in this section that pertain to flammable fuels.



This section introduces the hazards and safety precautions associated with installing, inspecting, maintaining or servicing this product. Before performing any task on this product, read this safety information and the applicable sections in this manual, where additional hazards and safety precautions for your task will be found. Fire, explosion, electrical shock or pressure release could occur and cause death or serious injury, if these safe service procedures are not followed.

Preliminary Precautions

You are working in a potentially dangerous environment of flammable fuels, vapors, and high voltage or pressures. Only trained or authorized individuals knowledgeable in the related procedures should install, inspect, maintain or service this equipment.

Emergency Total Electrical Shut-Off

The first and most important information you must know is how to stop all fuel flow to the pump/dispenser and island. Locate the switch or circuit breakers that shut off all power to all fueling equipment, dispensing devices, and Submerged Turbine Pumps (STPs).

 WARNING	
	The EMERGENCY STOP, ALL STOP, and PUMP STOP buttons at the cashier's station WILL NOT shut off electrical power to the pump/dispenser. This means that even if you activate these stops, fuel may continue to flow uncontrolled.
	
	You must use the TOTAL ELECTRICAL SHUT-OFF in the case of an emergency and not the console's ALL STOP and PUMP STOP or similar keys.

Total Electrical Shut-Off Before Access

Any procedure that requires access to electrical components or the electronics of the dispenser requires total electrical shut off of that unit. Understand the function and location of this switch or circuit breaker before inspecting, installing, maintaining, or servicing Gilbarco equipment.

Evacuating, Barricading and Shutting Off

Any procedure that requires access to the pump/dispenser or STPs requires the following actions:



- An evacuation of all unauthorized persons and vehicles from the work area
- Use of safety tape, cones or barricades at the affected unit(s)
- A total electrical shut-off of the affected unit(s)

Read the Manual

Read, understand and follow this manual and any other labels or related materials supplied with this equipment. If you do not understand a procedure, call the Gilbarco Technical Assistance Center (TAC) at 1-800-743-7501. It is imperative to your safety and the safety of others to understand the procedures before beginning work.

Follow the Regulations

Applicable information is available in National Fire Protection Association (NFPA) 30A; *Code for Motor Fuel Dispensing Facilities and Repair Garages*, NFPA 70; *National Electrical Code (NEC)*, Occupational Safety and Health Administration (OSHA) regulations and federal, state, and local codes. All these regulations must be followed. Failure to install, inspect, maintain or service this equipment in accordance with these codes, regulations and standards may lead to legal citations with penalties or affect the safe use and operation of the equipment.

Replacement Parts

Use only genuine Gilbarco replacement parts and retrofit kits on your pump/dispenser. Using parts other than genuine Gilbarco replacement parts could create a safety hazard and violate local regulations.

Safety Symbols and Warning Words

This section provides important information about warning symbols and boxes.

Alert Symbol



This safety alert symbol is used in this manual and on warning labels to alert you to a precaution which must be followed to prevent potential personal safety hazards. Obey safety directives that follow this symbol to avoid possible injury or death.

Signal Words

These signal words used in this manual and on warning labels tell you the seriousness of particular safety hazards. The precautions below must be followed to prevent death, injury or damage to the equipment:



DANGER: Alerts you to a hazard or unsafe practice which will result in death or serious injury.



WARNING: Alerts you to a hazard or unsafe practice that could result in death or serious injury.



CAUTION with Alert symbol: Designates a hazard or unsafe practice which may result in minor injury.

CAUTION without Alert symbol: Designates a hazard or unsafe practice which may result in property or equipment damage.

Working With Fuels and Electrical Energy

Prevent Explosions and Fires

Fuels and their vapors will explode or burn, if ignited. Spilled or leaking fuels cause vapors. Even filling customer tanks will cause potentially dangerous vapors in the vicinity of the dispenser or island.

DEF is non-flammable. Therefore, explosion and fire safety warnings do not apply to DEF fluid lines.

Important Safety Information

No Open Fire



Open flames from matches, lighters, welding torches or other sources can ignite fuels and their vapors.

No Sparks - No Smoking



Sparks from starting vehicles, starting or using power tools, burning cigarettes, cigars or pipes can also ignite fuels and their vapors. Static electricity, including an electrostatic charge on your body, can cause a spark sufficient to ignite fuel vapors. Every time you get out of a vehicle, touch the metal of your vehicle, to discharge any electrostatic charge before you approach the dispenser island.

Working Alone

It is highly recommended that someone who is capable of rendering first aid be present during servicing. Familiarize yourself with Cardiopulmonary Resuscitation (CPR) methods, if you work with or around high voltages. This information is available from the American Red Cross. Always advise the station personnel about where you will be working, and caution them not to activate power while you are working on the equipment. Use the OSHA Lockout/Tagout procedures. If you are not familiar with this requirement, refer to this information in the service manual and OSHA documentation.

Working With Electricity Safely

Ensure that you use safe and established practices in working with electrical devices. Poorly wired devices may cause a fire, explosion or electrical shock. Ensure that grounding connections are properly made. Take care that sealing devices and compounds are in place. Ensure that you do not pinch wires when replacing covers. Follow OSHA Lockout/Tagout requirements. Station employees and service contractors need to understand and comply with this program completely to ensure safety while the equipment is down.

Hazardous Materials

Some materials present inside electronic enclosures may present a health hazard if not handled correctly. Ensure that you clean hands after handling equipment. Do not place any equipment in the mouth

WARNING

In the event of inclement weather, including snow, ice, or flooding that makes driving conditions dangerous, please avoid servicing units. Always use available door stops to secure upper doors against unwanted/unexpected movement, especially during high winds. If necessary, reschedule service to avoid damage to the equipment. Weather may change unexpectedly; be aware of local weather conditions. During service, if conditions develop making service unsafe, close the unit(s) and proceed to a safe location.

WARNING

The pump/dispenser contains a chemical known to the State of California to cause cancer.

WARNING

The pump/dispenser contains a chemical known to the State of California to cause birth defects or other reproductive harm.



Gilbarco Veeder-Root encourages the recycling of our products. Some products contain electronics, batteries, or other materials that may require special management practices depending on your location. Please refer to your local, state, or country regulations for these requirements.

In an Emergency

Inform Emergency Personnel

Compile the following information and inform emergency personnel:

- Location of accident (for example, address, front/back of building, and so on)
- Nature of accident (for example, possible heart attack, run over by car, burns, and so on)
- Age of victim (for example, baby, teenager, middle-age, elderly)
- Whether or not victim has received first aid (for example, stopped bleeding by pressure, and so on)
- Whether or not a victim has vomited (for example, if swallowed or inhaled something, and so on)

WARNING



Gasoline/DEF ingested may cause unconsciousness and burns to internal organs. Do not induce vomiting. Keep airway open. Oxygen may be needed at scene. Seek medical advice immediately.

WARNING

DEF generates ammonia gas at higher temperatures. When opening enclosed panels, allow the unit to air out to avoid breathing vapors. If respiratory difficulties develop, move victim away from source of exposure and into fresh air. If symptoms persist, seek medical attention.

WARNING



Gasoline inhaled may cause unconsciousness and burns to lips, mouth and lungs. Keep airway open. Seek medical advice immediately.

WARNING



Gasoline/DEF spilled in eyes may cause burns to eye tissue. Irrigate eyes with water for approximately 15 minutes. Seek medical advice immediately.

WARNING



Gasoline/DEF spilled on skin may cause burns. Wash area thoroughly with clear water. Seek medical advice immediately.

WARNING

DEF is mildly corrosive. Avoid contact with eyes, skin, and clothing. Ensure that eyewash stations and safety showers are close to the work location. Seek medical advice/recommended treatment if DEF spills into eyes.

IMPORTANT: Oxygen may be needed at scene if gasoline has been ingested or inhaled. Seek medical advice immediately.

Lockout/Tagout

Lockout/Tagout covers servicing and maintenance of machines and equipment in which the unexpected energization or start-up of the machine(s) or equipment or release of stored energy could cause injury to employees or personnel. Lockout/Tagout applies to all mechanical, hydraulic, chemical, or other energy, but does not cover electrical hazards. Subpart S of 29 CFR Part 1910 - Electrical Hazards, 29 CFR Part 1910.333 contains specific Lockout/Tagout provision for electrical hazards.

Consignes de sécurité importantes

Remarque : Conserver cette section Consignes de sécurité importantes dans un endroit facilement accessible.

Cette section présente les dangers et les mesures de sécurité associées à l'installation, à l'inspection, à la maintenance et à l'entretien de ce produit. Avant d'effectuer une intervention sur ce produit, l'utilisateur doit lire ces consignes de sécurité et les sections applicables de ce manuel où sont exposés les dangers et mesures de sécurité à adopter relativement à son intervention. Un incendie, des explosions, des chocs électriques ou un relâchement de la pression pourraient survenir et provoquer des blessures graves voire la mort si ces procédures d'intervention sécurisée n'étaient pas observées.

Précautions préliminaires

Les interventions ont lieu dans un environnement potentiellement dangereux de vapeurs, carburants inflammables, et de pressions ou tensions élevées. Seuls les personnes formées ou agréées et connaissant les procédures concernées doivent installer, inspecter, maintenir ou entretenir cet équipement.

Coupeure totale d'urgence de l'énergie électrique

L'information la plus importante à connaître est de savoir arrêter tout écoulement de carburant vers la pompe/le distributeur et l'îlot. Repérer l'interrupteur ou les disjoncteurs qui coupent toute l'alimentation à toute la distribution de carburant, aux dispositifs de distribution et aux pompes immergées à turbine (STP).

⚠ AVERTISSEMENT

 Les boutons EMERGENCY STOP (Arrêt d'urgence), ALL STOP (Tout arrêter) et PUMP STOP (Arrêt de la pompe) au niveau de la caisse de la station ne couperont PAS l'alimentation électrique de la pompe/du distributeur. Autrement dit, le carburant continue de circuler sans contrôle même quand on actionne ces dispositifs d'arrêts.

 Vous devez utiliser TOTAL ELECTRICAL SHUT-OFF (SYSTÈME DE FERMETURE ÉLECTRIQUE TOTAL) en cas d'urgence et non les boutons ALL STOP (TOUT STOPPER) ou PUMP STOP (STOPPER POMPE) ou autres touches semblables.

Coupeure totale de l'énergie électrique avant l'accès

Toute procédure exigeant d'accéder aux composants électriques ou à l'électronique du distributeur nécessitent de couper l'énergie électrique de cette unité. Il est important de comprendre la fonction et l'emplacement de cet interrupteur ou disjoncteur avant d'inspecter, d'installer, de maintenir ou d'entretenir les équipements de Gilbarco.

Évacuation, bouclage de la zone et coupeure de l'alimentation

Toute procédure exigeant l'accès à la pompe/au distributeur ou aux pompes immergées à turbine (STP) exige les actions suivantes:



- l'évacuation de tous les véhicules ou personnes non autorisées de la zone d'intervention
- l'utilisation de ruban de sécurité, de cônes ou d'un bouclage des unités affectées
- la coupeure totale de l'énergie électrique des unités affectées

Lire le manuel

L'intervenant doit lire, comprendre et suivre ce manuel et toutes les autres étiquettes ou documentations apparentées fournies avec cet équipement. Si l'intervenant ne comprend pas une procédure, il doit appeler un Prestataire de service agréé par Gilbarco ou le Centre d'assistance de Gilbarco au 1-800-743-7501. Il est impératif pour sa sécurité et celle d'autrui de bien comprendre les procédures avant d'engager les interventions.

Respecter les réglementations

Les informations applicables sont disponibles dans la NFPA (National Fire Protection Association) 30A; le *Code pour les ateliers de réparation automobile et les sites de distribution de carburant Repair Garages*, NFPA 70; le *Code national américain de l'électricité NEC (National Electrical Code)*, les règlements de Occupational Safety and Health Administration (OSHA) des États-Unis, ainsi que dans les codes fédéraux, provinciaux et locaux. Toutes ces réglementations doivent être observées. Le non-respect de ces codes, réglementations et normes lors de l'installation, de l'inspection, de la maintenance ou de l'entretien de ces équipements pourrait mener à des contraventions avec sanctions ou affecter l'utilisation sécurisée de ces équipements.

Pièces de rechange

N'utiliser que d'authentiques pièces de rechange et trousse de modification Gilbarco sur la pompe/le distributeur. L'utilisation de pièces autres que d'authentiques pièces de rechange Gilbarco pourrait entraîner un risque d'accident et enfreindre la réglementation en vigueur.

Symboles de sécurité et mises en garde



Cette section fournit des informations importantes sur les encadrés et symboles de mise en garde.

Symbole d'avertissement

 Ce symbole d'avertissement est utilisé dans ce manuel et sur les étiquettes de mise en garde pour signaler une précaution à suivre afin d'éviter les risques d'accidents potentiels. Observer les directives de sécurité qui suivent ce symbole afin d'éviter des blessures potentielles, voire la mort.

Termes de signalisation

Les termes de signalisation utilisés dans ce manuel et sur les étiquettes de mise en garde informent l'opérateur de la gravité des risques d'accident particuliers. Observer les précautions suivantes pour éviter les dommages matériels et corporels, voire la mort:

-  **DANGER:** Ce message signale un danger ou une pratique dangereuse qui entraînera des blessures graves, voire la mort.
-  **AVERTISSEMENT:** Ce message signale un danger ou une pratique dangereuse qui pourrait entraîner des blessures graves, voire la mort.
-  **ATTENTION** avec le symbole d'avertissement : Ce message désigne un danger ou une pratique dangereuse qui pourrait entraîner des blessures mineures.
- ATTENTION** sans le symbole d'avertissement : Ce message désigne un danger ou une pratique dangereuse qui pourrait entraîner l'endommagement des biens ou du matériel.

Utilisation des carburants et de l'énergie électrique

Prévenir les explosions et les incendies

Les carburants et leurs vapeurs exploseront ou brûleront s'ils s'enflamment. Les fuites ou les déversements de carburant provoquent des vapeurs. Même le remplissage du réservoir des clients provoquera des vapeurs potentiellement dangereuses à proximité du distributeur ou de l'îlot.

Consignes de sécurité importantes

Pas de feu en plein air



Les flammes nues des allumettes, briquets, torches de soudage ou d'autres sources capables d'enflammer les carburants et leurs vapeurs.

Pas d'étincelles, interdit de fumer



Les étincelles des véhicules au démarrage, le démarrage ou l'utilisation d'outils électriques, les cigarettes, cigares ou pipes allumées, peuvent également enflammer les carburants et leurs vapeurs. L'électricité statique, y compris une charge électrostatique sur le corps, peut provoquer une étincelle suffisante pour enflammer les vapeurs de carburant. Déchargez la charge électrostatique chaque fois que vous sortez d'un véhicule, en touchant sa surface métallique, avant d'approcher l'îlot de distribution.

Travail en solitaire

Il est vivement recommandé d'être accompagné d'une personne capable de donner les premiers soins pendant une intervention. L'intervenant doit se familiariser avec les méthodes de réanimation cardiopulmonaire (RCP) s'il travaille sur ou à proximité de tensions élevées. Ces informations sont disponibles auprès de la Croix-Rouge. L'intervenant doit toujours indiquer au personnel de la station l'endroit où il va intervenir, et signaler de ne pas actionner l'alimentation électrique lors de son intervention sur l'équipement. Utiliser les procédures de cadenassage et d'étiquetage de l'OSHA. Si l'intervenant n'est pas familiarisé avec cette exigence, il doit consulter ces informations dans le manuel de service et dans la documentation de l'OSHA.

Travailler en sécurité avec l'électricité

Veiller à appliquer des pratiques sécuritaires et établies lors de tout travail avec des appareils électriques. Les appareils mal préparés peuvent provoquer un incendie, une explosion ou un choc électrique. Vérifier que les mises à la terre sont correctement établies. S'assurer que les mastics et dispositifs d'étanchéité sont en place. Veiller à ne pas pincer les fils lors du repositionnement des capots. Respecter les exigences de cadenassage et d'étiquetage de l'OSHA. Les employés de la station et les prestataires de service doivent comprendre ces exigences et les respecter complètement pour garantir la sécurité lorsque l'équipement est hors service.

Matières dangereuses

Certaines matières présentes dans les enceintes électroniques peuvent présenter un danger pour la santé si elles ne sont pas manipulées correctement. Veiller à se nettoyer les mains après avoir manipulé l'équipement. Ne mettre aucun équipement dans la bouche.

AVERTISSEMENT

La pompe/le distributeur contient une substance chimique connue dans l'État de Californie pour provoquer le cancer.



Gilbarco Veeder-Root vous encourage à faire la pratique de recyclage de nos divers produits. Certains de nos produits contiennent des pièces électroniques, des piles, ou d'autres matériaux qui peuvent nécessiter des pratiques de gestion des déchets ou de recyclage en fonction de votre emplacement. Veuillez-vous référer à votre municipalité, aux normes provinciales ou fédérales pour connaître leurs diverses réglementations en vigueur sur le sujet.

AVERTISSEMENT

La pompe/le distributeur contient une substance chimique connue dans l'État de Californie pour provoquer des anomalies congénitales ou exercer des effets nocifs sur la reproduction.

En cas d'urgence

Informez le personnel du service d'urgence

Collecter les informations suivantes et informer le personnel du service d'urgence :

- Lieu de l'accident (par exemple, adresse, avant/arrière du bâtiment, etc.)
- Nature de l'accident (par exemple, crise cardiaque éventuelle, renversé par une voiture, brûlures, etc.)
- Âge de la victime (par exemple, bébé, adolescent, âge moyen, personne âgée)
- Si la victime a reçu ou non les premiers soins (par exemple, arrêt des saignements par pression, etc.)
- Si la victime a vomi ou non (par exemple, si elle a avalé ou inhalé quelque chose, etc.)

AVERTISSEMENT



L'ingestion d'essence peut provoquer une perte de conscience et des brûlures aux organes internes. Ne pas induire de vomissements. Garder les voies respiratoires ouvertes. Un apport en oxygène peut s'avérer nécessaire sur place. Solliciter immédiatement l'avis d'un médecin.

AVERTISSEMENT



L'inhalation d'essence peut provoquer une perte de conscience et des brûlures aux lèvres, à la bouche et aux poumons. Garder les voies respiratoires ouvertes. Solliciter immédiatement l'avis d'un médecin.

AVERTISSEMENT



Le déversement d'essence dans les yeux peut provoquer des brûlures aux tissus oculaires. Rincer les yeux sous l'eau pendant environ 15 minutes. Solliciter immédiatement l'avis d'un médecin.

AVERTISSEMENT



Le déversement d'essence sur la peau peut provoquer des brûlures. Laver abondamment la région affectée à l'eau claire. Solliciter immédiatement l'avis d'un médecin.

IMPORTANT: Un apport en oxygène peut s'avérer nécessaire sur place en cas d'ingestion ou d'inhalation d'essence. Solliciter immédiatement l'avis d'un médecin.

Cadenassage/étiquetage

Cadenasser et étiqueter les capots lors de l'entretien et de la maintenance des machines et des équipements afin d'éviter qu'une mise sous tension ou un démarrage imprévu des machines ou des équipements ou la libération de l'énergie emmagasinée ne provoquent des blessures sur les employés ou le personnel. La procédure de cadenassage et d'étiquetage s'applique à toutes les énergies mécaniques, hydrauliques, chimiques ou autres, mais ne couvre pas les dangers électriques. La sous-section S de 29 CFR Partie 1910 - Risques liés à l'électricité, 29 CFR Partie 1910.333 contient une disposition spécifique de verrouillage/étiquetage concernant les risques électriques.

Federal Communications Commission (FCC) Warning

This equipment has been tested and found to comply with the limits for a Class A digital device pursuant to Part 15 of the FCC rules. These limits are designed to provide reasonable protection against harmful interference when the equipment is operated in a commercial environment. This equipment generates, uses, and can radiate radio frequency energy, and if not installed and used in accordance with the instruction manual, may cause harmful interference to radio communications. Operation of this equipment in a residential area is likely to cause harmful interference in which case the user will be required to correct the interference at his own expense. Changes or modifications not expressly approved by the manufacturer could void the user's authority to operate this equipment.

Supplier's Declaration of Conformity (PA0422 series)



47 CFR § 2.1077 Compliance Information
Unique Identifier: BRCM2.64 PA0422
Responsible Party - U.S. Contact Information
Gilbarco Inc.
7300 West Friendly Avenue
Greensboro, North Carolina, USA
27410-6200
1-336-547-5000

Supplier's Declaration of Conformity (PA0435 series)

Supplier's Declaration of Conformity
47 CFR § 2.1077 Compliance Information
Unique Identifier: BRCM2.64 PA0435
Responsible Party - U.S. Contact Information
Gilbarco Inc.
7300 West Friendly Avenue
Greensboro, North Carolina, USA
27410-6200
1-336-547-5000.

Before You Begin

Read and follow all safety information provided in “[Important Safety Information](#)” on [page 5](#) and *MDE-3804 Encore and Eclipse Start-up/Service Manual*.

 CAUTION	
	A properly grounded Electrostatic Discharge (ESD) wrist strap must be worn while servicing any electronic devices or components. Failure to use electrostatic precautions may damage electronic components and void warranty.

To prepare the site and dispenser/pump for the installation, proceed as follows:

- 1 Before beginning the installation, it is important to know:
 - The site POS and two-wire wiring scheme
 - Number of units that will be running FlexPay Connect v2 (high speed)
 - The back room configuration

Note: Do not run high-speed connection to units that will not be processing high-speed transactions (for example, a kerosene unit off to the side of the forecourt).
- 2 Ensure that all fuel sales are complete.
- 3 Inform the manager that the power to the D-Box will be disconnected and communication to the forecourt will be disrupted while installing BRCM2.x. Customers will not be able to purchase fuel, but they can still purchase merchandise in the store.
- 4 Barricade the entire forecourt.
- 5 Remove power to the D-Box at the breaker panel. Follow OSHA lockout/tagout procedures.

 WARNING	
Failure to turn off the unit during the kit installation may cause injury or bodily harm from electrical shock. Ensure that all power to the unit is switched off before and during kit installation.	

Summary of BRCM2 Variants

	With D-box Boards		No D-box Boards (M14881 only)	
	Old	New	Old	New
With EMV: Used with POS	NeXGen, some Commanders w/o FCI, OK to use with Passport		Passport™, NCR, Commander with FCI	
BRCM2	PA04220000022B (1)	PA0435200032** (2)	PA04222000002B (3)	PA0435200002 (2)
Expander	PA0432000322	PA043200032	PA0432200002	PA0432200002

BRCM2 and Expander each only have 16 physical connections to a dispenser. However, you can use Expander(s) to increase the number of dispensers supported from the one BRCM2.

Notes	Max number of dispensers supported with Expander(s)	Number of RJ-45 Jacks on BRCM 2	Other
1.	Only supports TCP connections to 32 dispensers	Four with security slide	Some customers used the old model and would simply bypass the D-box boards and connect to the Field Wiring Board (FWB) to use it like a 002B. This is no longer possible because the new design PA0435200032 combines the two D-box boards and the Field Wiring Board onto one board with no way to “cut into” it. See Figure 5 on page 16 or Figure 7 on page 18 for alternate solutions.
2.	Supports TCP connections to 64 dispensers	One	The most direct solution to support TCP connections to 64 dispensers is the PA0435200002; however, the PA0435200032 can also be used. See Figure 5 on page 16 and Figure 7 on page 18 for details.
3.	Only supports TCP connections to 32 dispensers	Four with security slide	-

Mounting Requirement and In-Store Wiring

The BRCM2 is mounted with two fasteners, shown on the left and the right side of the assembly (see [Figure 2](#)). The unit must be mounted on the wall above the wiring trough and be connected to the trough with a regulatory-approved conduit method.

After mounting, each fastener must be able to withstand a minimum of a 30-pound shear force and a 30-pound pull force.

Figure 2: Fasteners for Mounting

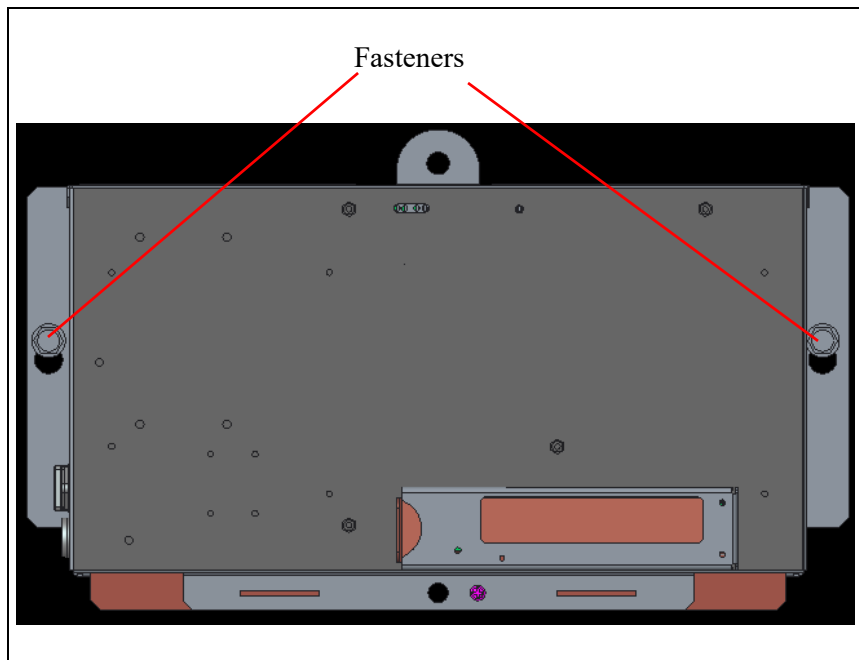

AC Power Distribution

The AC power is plugged into the lid of the BRCM2. Models with distribution boards (PA04220000022B, PA04220003022B, and PA0435200032) also require the supplied external power cord on the lid to power the base portion of the unit.

Forecourt wiring

The wires from the BRCM2 to the wiring trough is considered AC wiring by the NEC. Therefore, they must be routed inside conduit. Knockouts are provided on the bottom edge of the BRCM2.

Further, if the BRCM2 is being used in pass-through mode, the wiring between the BRCM2 and the forecourt controller is still considered AC wiring and must also be routed in conduit.

BRCM2 Adapter Cables

The following adapters are provided in an accessory bag:

Adapters	Specifications
R19263-G1	This adapter is 9 positions wide, with 4 wires, each shorting two positions. It is used in pass-through mode to accept the data from a forecourt controller. To use this adapter: for each position required, cut the wire loop and use a wire-nut to make connection to the wire going to the forecourt controller.
R19263-G4	This adapter is 8 positions wide, with 8 wires, provided with a crimped-on cap. This is used on every BRCM2, either on the M14881 Field Wiring Board or the M16107 combined D-box board. It is used to make the field connection to the dispenser. To use this adapter for each dispenser you are connecting, cut the two adjacent caps off and wire-nut to the field wiring to the dispenser. DO NOT SHORT UNUSED WIRES ON THIS CABLE, it will severely degrade signal quality.
R19249-G1	If the BRCM2 has a D-box function, these adapters are provided. The BRCM2 ships with a POS current loop interface adapter installed. However, to convert to a RS-422 POS interface, remove the current loop interface connector from the BRCM2 assembly and install this adapter instead. Plug the 10-pin connector into its mate on the D-box board. See " D-Box Board Jumper Configurations " on page 21 for required D-box board jumper changes
M15247A001	Used with PA0422000022B and PA04220003022B to connect the D-box board(s) to the Field Wiring Board.

General Site Configurations

Note: Many of these diagrams apply to EMV solutions. In general, if a non-EMV CRIND current loop is required, use a BRCM2 with internal D-box support or use an external D-box for the CRIND current loop.

Refer “Mounting Requirement and In-Store Wiring” on page 12, “General Site Configurations” on page 14, and “BRCM2 Field Wiring Detail for Pass-Through Mode (PA04222000002B and PA0435200002)” on page 19 to see the BRCM2 details.

Passport EMV

Figure 3: EMV Passport with Applause

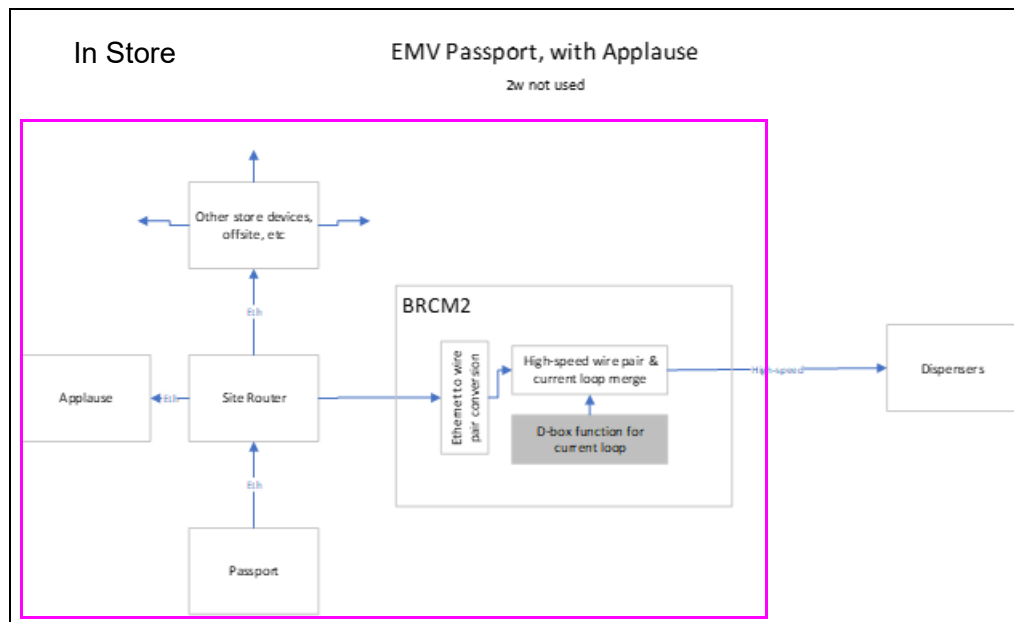

If a current loop connection to the CRIND is required, there are two possible solutions:

- Use an external D-box and use a BRCM2 ending with ‘02 in pass-through mode.
- Use the internal D-box function and use a BRCM2 ending with ‘22x or ‘32.

Third Party POS Providing Current Loop Pass-Through (to DCM3/Omnia)

Examples of this are VFI w/o FCI and NeXGen. The BRCM2 is used in pass-through mode.

Figure 4: POS Providing Multiple 2W Drives and BRCM2 Adds High-speed to Omnia

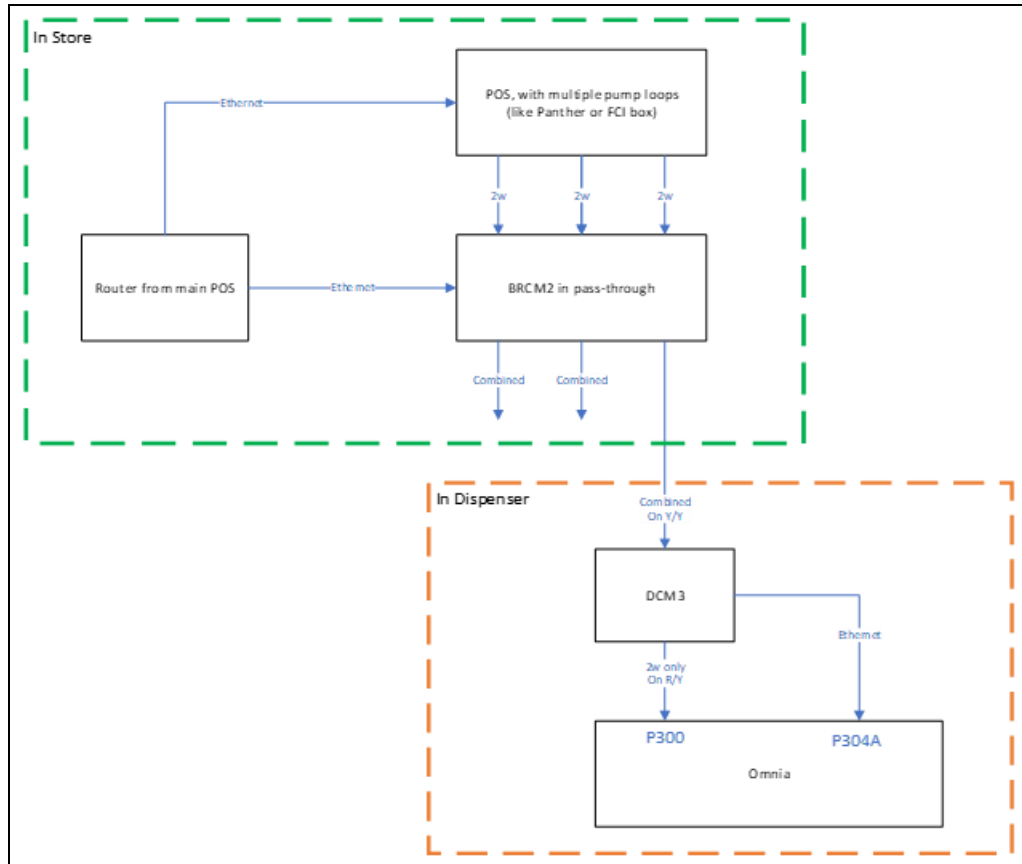

Third Party POS Requiring Current Loop Non-Pass-Through (to DCM3/ Omnia)

Alternately, if dual wire-pairs are available, the pump current loop can be driven separately as shown below:

Figure 5: Alternate Solution using BRCM2 for CRIND High-speed IP and Separate Pump 2W Path to Omnia

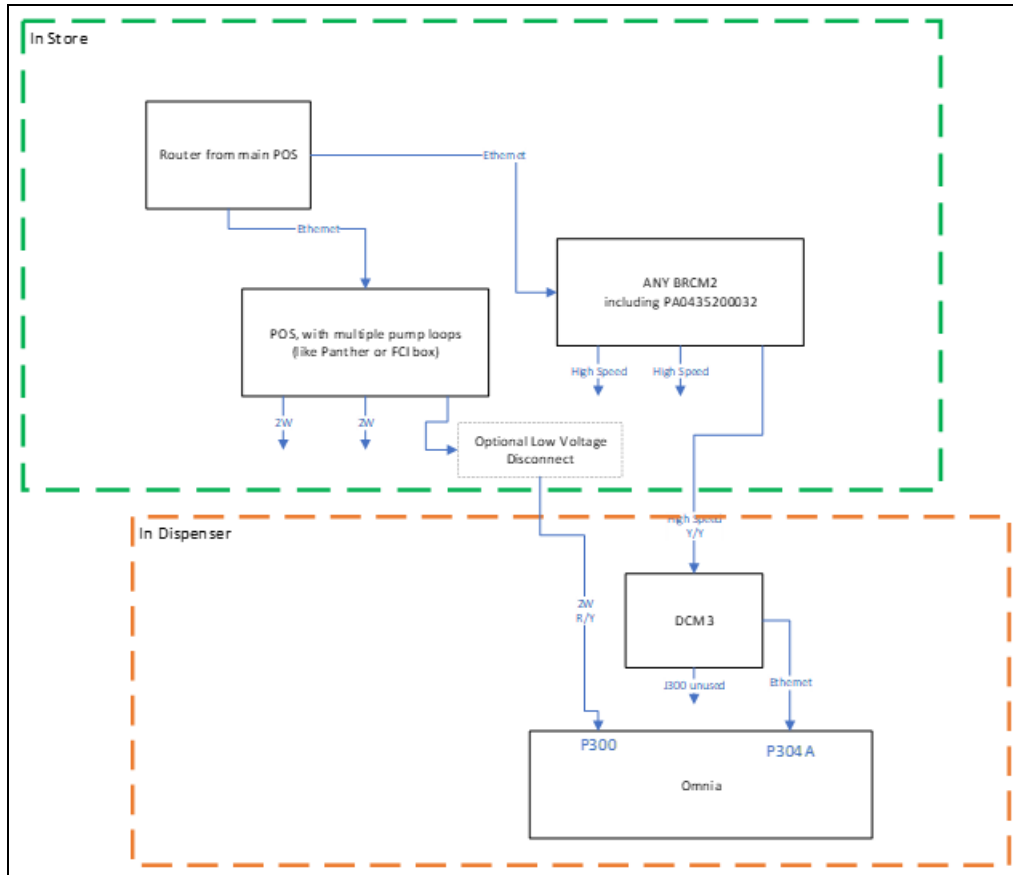

Third Party POS Providing Current Loop Pass-Through (to DCM2)

Figure 6: POS Providing Multiple 2W Drives and BRCM2 adds High-speed to DCM2/CCP

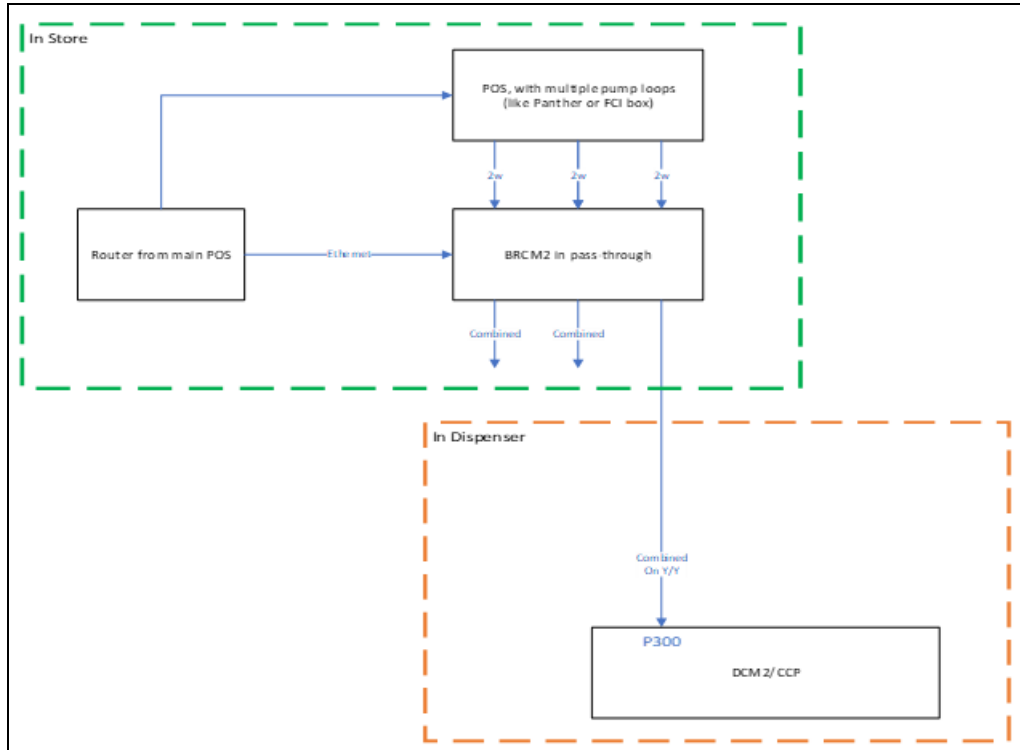

Third Party POS Requiring Current Loop Non-Pass-Through (to DCM2)

Figure 7: Alternate Solution using BRCM2 for CRIND High-speed IP and Separate Pump 2W Path to DCM2/CCP

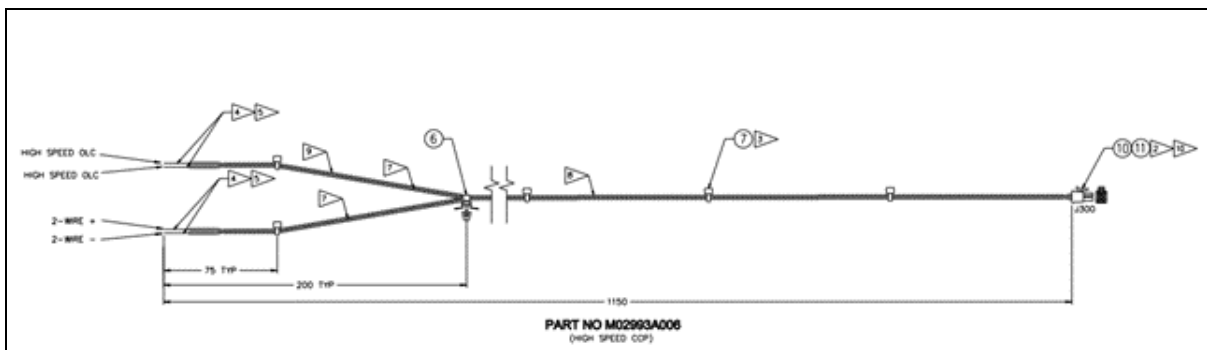
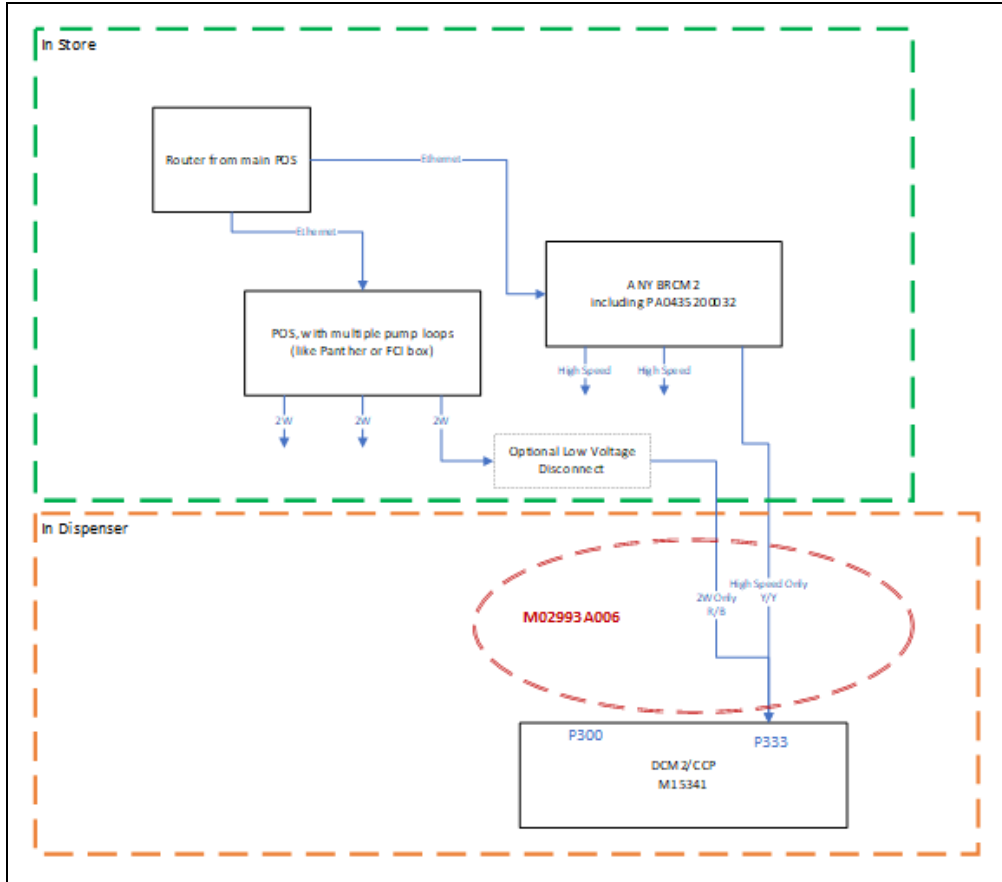

BRCM2 Field Wiring Detail for Pass-Through Mode (PA04222000002B and PA0435200002)

The **red** wire pairs in [Figure 8](#) shows the current loop pairs coming from the external D-box, FCI box, or NCR device.

The **blue** wire pairs route to the dispenser and contain the current loop information from the red wires + the high-speed data on the green wires. Any unused **blue** wires must NOT be shorted together.

Figure 8: Pass-through Mode Wires at Field Wiring Board

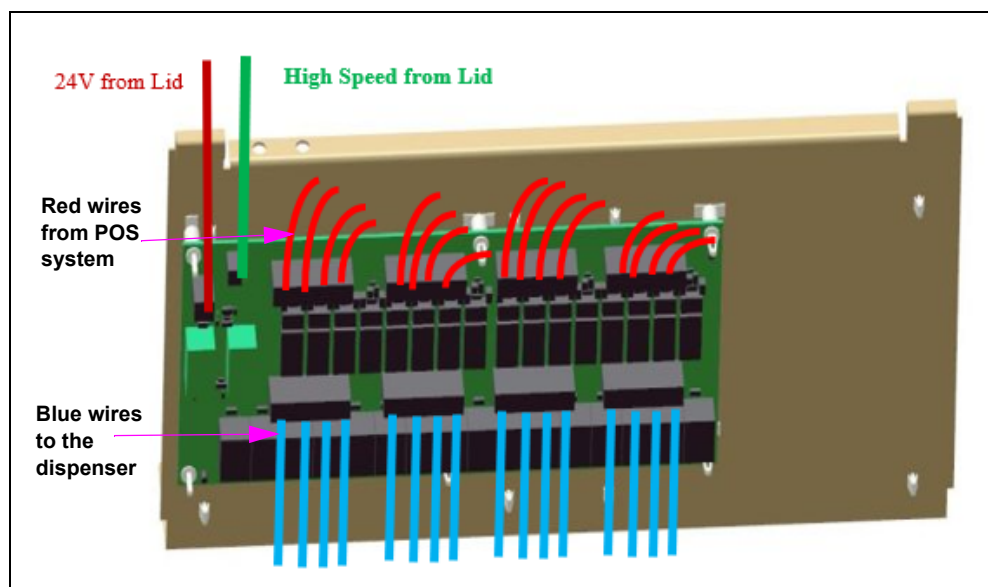

BRCM2 Field Wiring Detail and Configuring the PA0422000x022B

Note: Figure 9 and Figure 10 illustrate that for sites that have legacy dispensers, you DO NOT connect them to the high-speed signal. Instead, use wire-nuts to splice the field wiring to the M15247A001 wire pairs to the D-box board.

Figure 9: Example of Wiring for More Than 8 Dispensers (Two Current Loops to POS)

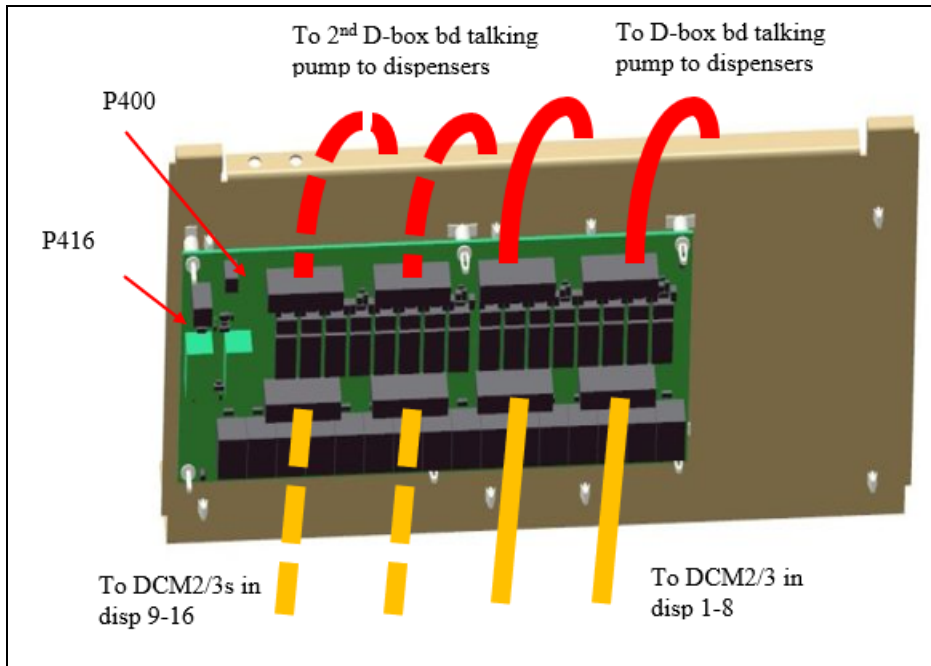
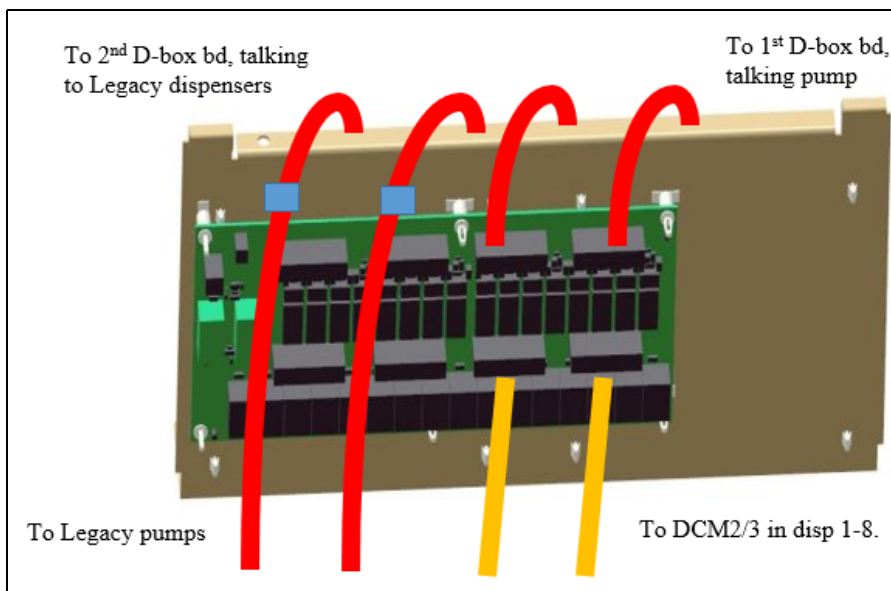

Figure 10: Examples for Sites with Legacy Dispenser



D-Box Board Jumper Configurations

PA0422000022B D-box board (T17641) jumpers

Figure 11: T17641 Detail

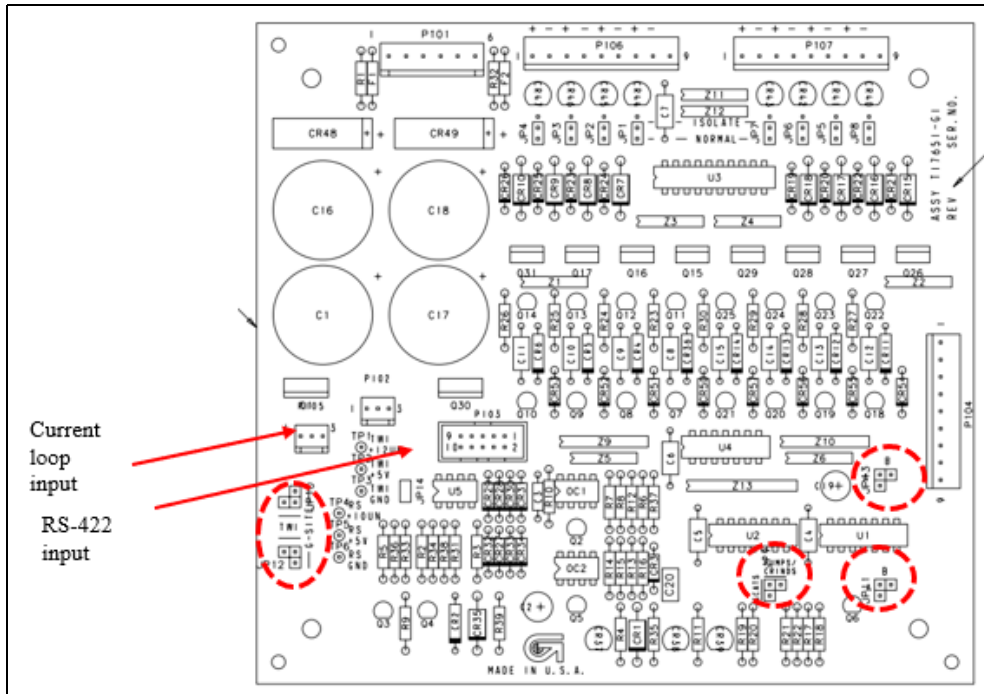

POS Connection

	Current Loop	RS-422
JP10	B	A
JP12	B	A
JP14	Out	In

Data Routing on board

	Single board or 2 independent channels to POS	Dual board, one connection to POS, board w/connection	Dual board, one connection to POS, board w/o connection
JP11	B	B	A
JP13	B	A	B
45mA current to dispenser (GVR)		34mA current to dispenser	
JP9-B		JP9-A	

PA04220003022B D-box board (M16377) jumpers

Figure 12: M16377 Detail

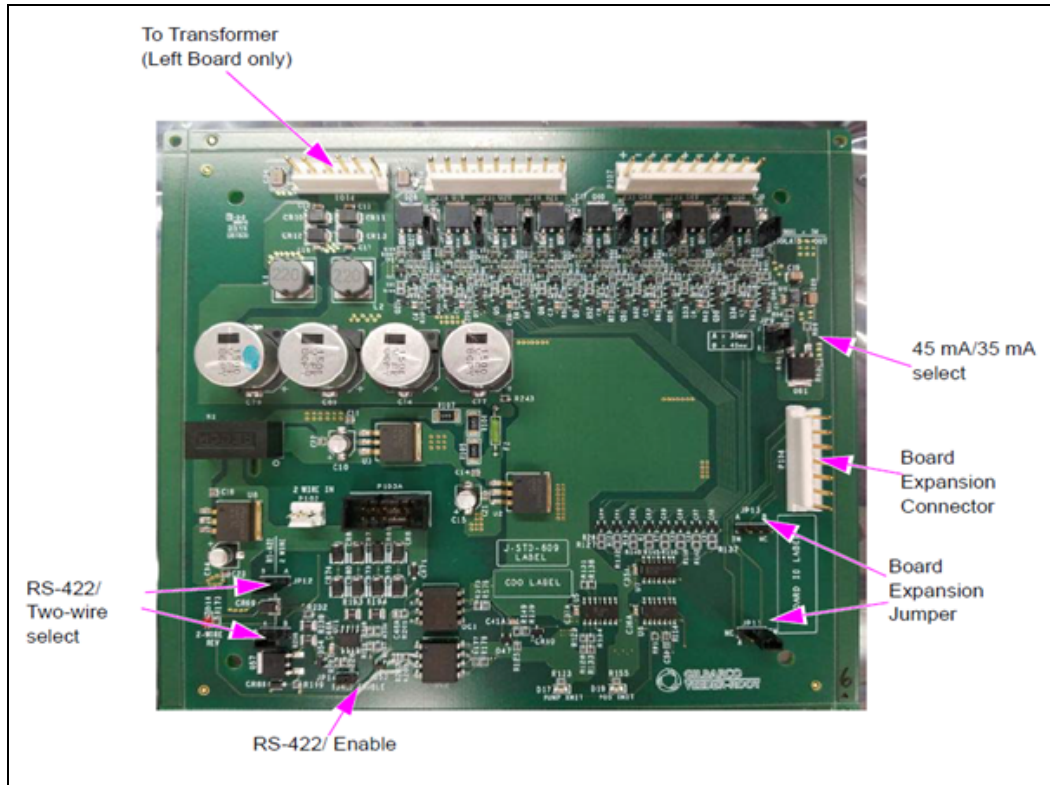

POS Connection

	Current Loop	RS-422
JP10	B	A
JP12	B	A
JP14	Out	In

Data Routing on board

	Single board or 2 independent channels to POS	Dual board, one connection to POS, board w/connection	Dual board, one connection to POS, board w/o connection
JP11	B	B	A
JP13	B	A	B
45ma current to dispenser (GVR)		34ma current to dispenser	
JP9-B		JP9-A	

Wiring Field Detail and Configuring the PA043520002

The PA043520002 combines the two D-box boards and the Field Wiring Board in the M16107.

Figure 13: M16107 Detail

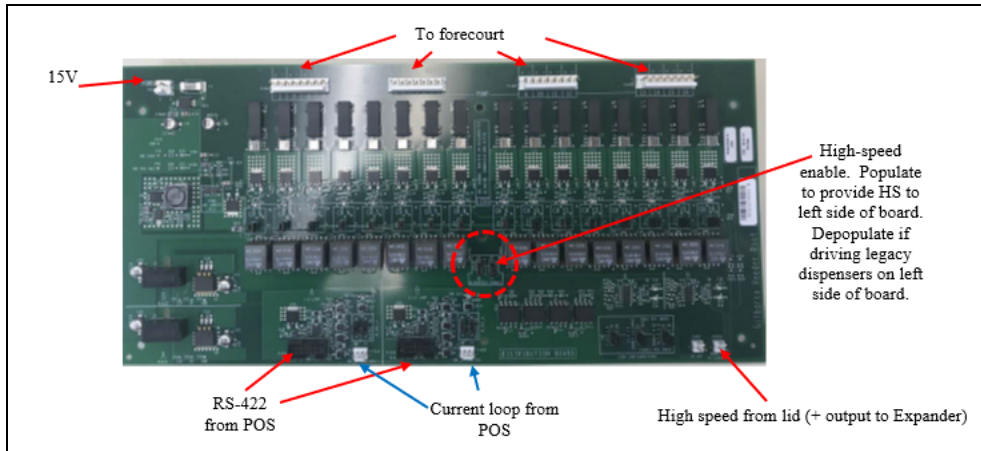

Jumper selection for Connection to POS

Jumper	For RS-422 to POS	For Two-wire to POS
JP_POS_A	A-RS422 position	B-Two-wire position
JP_POS_B	A-RS422 position	B-Two-wire position

Jumper selection for Loop Configuration

Jumper	Single POS input	Dual POS Input
JP_RX	A- (1-16 RX Enable)	B-(1-8 RX Enable)
JP_TX	A-(9-16 TX A)	B-(9-16 TX B)

Loop current selection

20mA	35mA	45mA
A	B	No Jumper

Figure 14: Lower Portion of Board Detail View

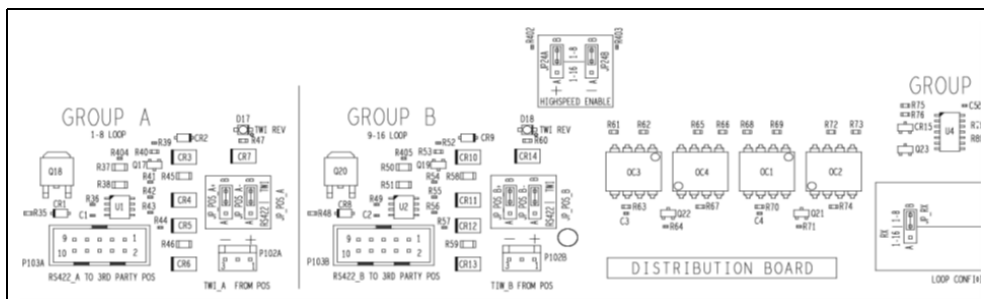

Upgrade existing D-box using PA0422200002x, or PA0435200002

To upgrade the existing D-box, proceed as follows:

- 1 Power down the existing D-box by removing the power cord from the outlet and the chassis.
- 2 Open the lid of the existing D-box.
- 3 Remove the transformer connections to both D-boxes (the existing D-box and the PA0422200002). Remove the existing field wiring connectors.

Figure 15: Removing Field Wiring Connectors



- 4 Remove the field wiring board tray assembly from PA0422200002.
- 5 Remove the lip panel from the PA0422200002 and transfer it to the existing D-box. Mount it with the flat surface facing towards the user.
- 6 Discard the empty chassis.
- 7 Remove the D-box tray.

- 8 Remove the D-box boards from the D-box tray from the back, leaving the stand-offs in the boards with the help of a 3/16" nut driver or needle-nose pliers.

Figure 16: Squeezing Retaining Clips to Remove Standoff



- 9 Transfer the boards and standoffs on the field wiring tray.
- 10 Use the included 9-pin to 9-pin connectors to connect the field wiring board to the D-box boards.

Figure 17: Old D-Box Boards Transferred Onto New Tray

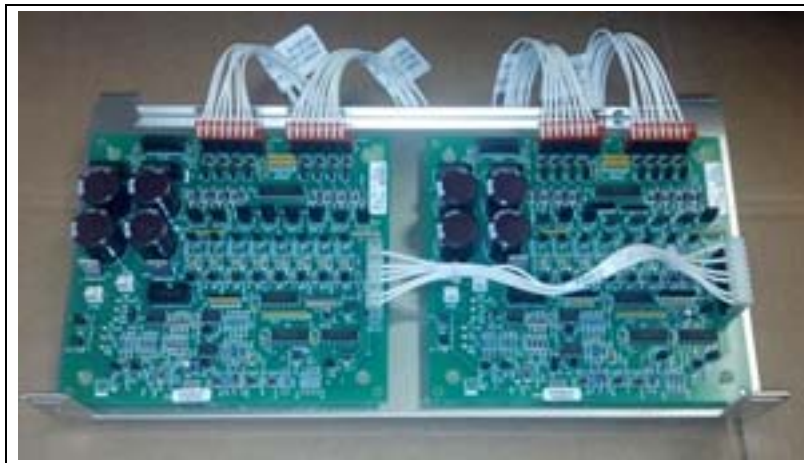

- 11 If the existing field wiring is using 9-pin connectors, the field wiring MUST be transferred onto the supplied 8 pin connectors. This is crucial to avoid degradation of the high-speed signal.
- 12 Move the field wiring tray into the existing D-box on the wall, tilting it outward to connect the 8-pin field wiring connectors.

- 13 Temporarily, suspend the lid assembly from the tab panel (see [Figure 18](#)).

Figure 18: Suspending Lid Assembly from Tab Panel

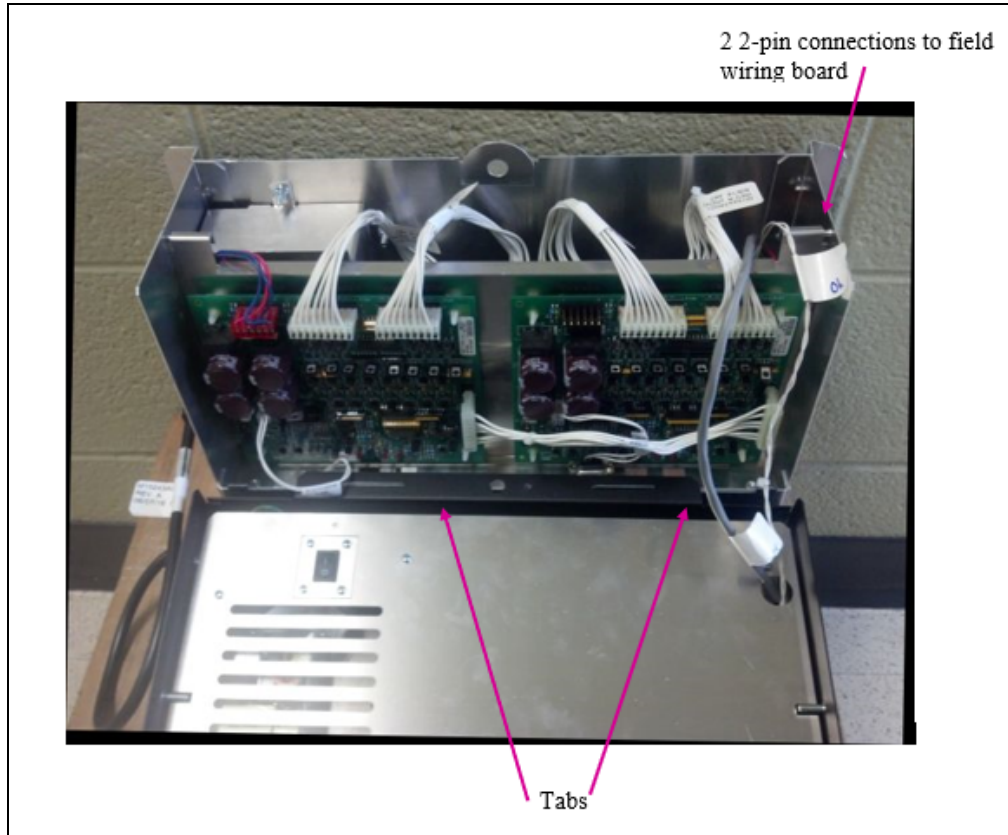

- 14 Connect the 2, 2-pin connectors to the field wiring board.
- 15 Connect the D-box board transformer.
- 16 Review that your new configuration does not affect the D-box jumper settings. For reference, see jumper functions for the appropriate D-box board.
- 17 Power up the D-box by connecting AC power to the D-box lid and connect the lid output to the D-box. If the box does not power up, verify that the switch on the lid is in the “ON” position. When the unit is properly powered, the board in the lid will be lit, as will the LEDs on the field wiring board. Additionally, the D-box boards will be powered.
- 18 Lift the lid assembly off the tab panel and close the completed assembly.
- 19 Connect the RJ-45 connector from the Applause server or other high-speed data source.

RJ-45 Access

Models PA04220000022B and PA04220000002B come with a slide that allows unused RJ-45 connectors to be covered. There is a screw on the inside of the cover that can be loosened to allow it to be adjusted, then secured in place.

Other models only have one RJ-45 jack on the side of the lid.

Figure 19: RJ-45 Access

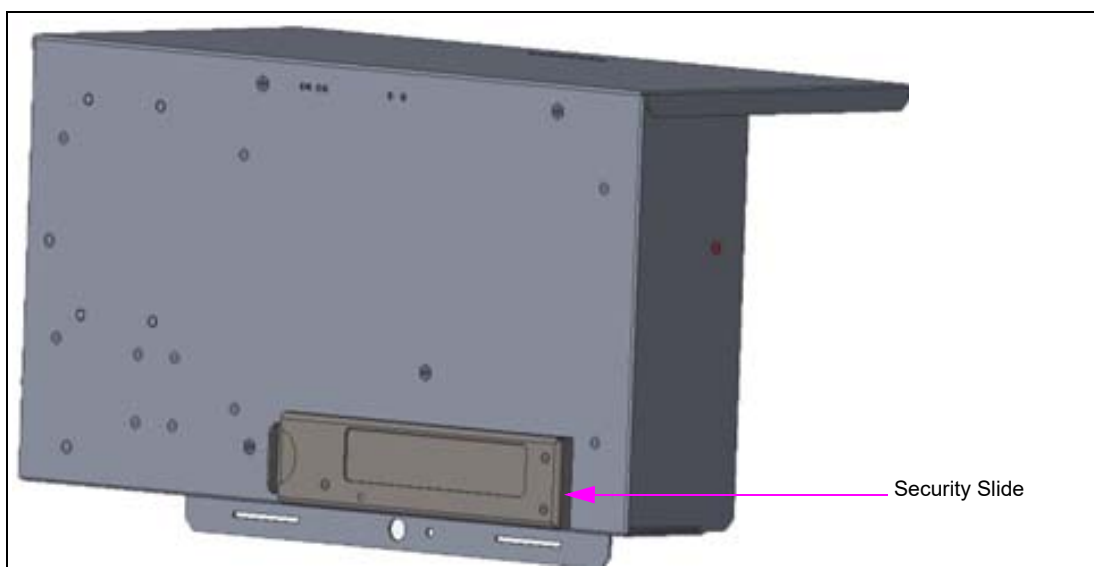

Networking Considerations

Typically, the BRCM2 is connected to the site's POS(s) via a secure router. The dispensers are on the same subnet as the POS. It is perfectly acceptable to have two (or more) POS systems connected to the BRCM2 via the secure router. The only restriction is that the POS systems have separate subnets and their corresponding dispensers be on those same subnets.

BRCM2 Tool

The BRCM2 tool is used to update settings in the BRCM2. The update function **MUST** be run on site startup or if the BRCM2 is replaced. If it is not, dispensers may go offline randomly.

Additionally, the BRCM2 tool has a diagnostic function that will measure the signal quality to each dispenser, and optionally map that to the IP addresses of the dispensers.

The BRCM2 tool is available from the Extranet. The downloaded zip file includes instructions for use.

Applause™ Media System, The Advantage™ Series, Eclipse™, E-CIM™, FlexPay™, Insite360™, and Passport™ are trademarks of Gilbarco Inc. CRIND®, Encore®, Gilbarco®, Legacy®, and TRIND® are registered trademarks of Gilbarco Inc. GOLDSM is a service mark of Gilbarco Inc.

All product names, logos, and brands are the property of their respective owners and are for identification purposes only. Use of these names, logos, and brands does not imply endorsement.



© 2022 Gilbarco Inc.
7300 West Friendly Avenue · Post Office Box 22087
Greensboro, North Carolina 27420
Phone (336) 547-5000 · <http://www.gilbarco.com> · Printed in the U.S.A.
MDE-5265F BRCM2.x Installation and Upgrade Instructions · February 2022