

TLS Monitoring Systems

Installation & Safety Guide for Technicians

Notice

Veeder-Root makes no warranty of any kind with regard to this publication, including, but not limited to, the implied warranties of merchantability and fitness for a particular purpose.

Veeder-Root shall not be liable for errors contained herein or for incidental or consequential damages in connection with the furnishing, performance, or use of this publication.

The information contained in this publication may be subject to change without notice.

This publication contains proprietary information which is protected by copyright. All rights reserved. No part of this publication may be photocopied, reproduced, or translated to another language without the prior written consent of Veeder-Root.

Example Illustrations

Illustrations used in this publication may contain components that are customer supplied and not included with the Veeder-Root device. Please check with your Veeder-Root Distributor for recommended installation accessories.

Introduction

General 1
 Installation Levels 1
 Product Description 2
 Systems..... 2
 In-Tank Probes 2
 Leak Detection Sensors 2
 Health And Safety 3
 Safety Symbols..... 3
 General..... 3
 Danger Areas 4
 General Overview Of The ATEX Directive 4
 Associated Apparatus..... 4
 Intrinsically Safe Apparatus 4
 Quality System 5
 Surge Protectors 5

System Consoles

Console Location 6
 Console Dimensions 6
 Power Requirements 7
 Console Installation Examples 7
 TLS Terminal Box Location, If Required 12

Intrinsically Safe Apparatus

Mag Probe Installations 13
 Mag Probe Installation Using A Process Connection 13
 Mag Probe Riser Pipe Installations 15
 Mag-FLEX Probe Installations 17
 Mag Sump Sensor 18
 Vacuum Sensor 19
 DPLLD Transducer 20
 Twin-Skin Piping Sump 20
 Interstitial Sensors 22
 Steel Tank Sensors 23
 Sump Sensors 24
 Dispenser Pan Sensors 25
 Position-Sensitive Sensors 26
 Containment Sump Sensors 27
 Hydrostatic Sensors 28
 Monitoring Wells 29
 Groundwater Sensors..... 29
 Vapour Sensors..... 29
 Discriminating Dispenser Pan And Containment Sump Sensors 32
 Discriminating Interstitial Sensor For Double-Skin fibreglass Tanks 33
 MicroSensor 34

Field Wiring

Field Cable Ducting35
 Equipment Connected To The RS-232 Port35
 External Inputs (TLS-350, TLS-450, TLS-450PLUS, TLS-XB Or TLS-300)36
 Output Relays36
 TLS High Level Alarm36
 Cable Specifications36
 Field Wiring39
 Probe To TLS Console39
 Maximum Cable Lengths.....39
 Ducting Entry To System Console Location39
 Relay Output Wiring39

Appendix A - Assessment Documents

Appendix B - TLS Product Labels

Appendix C - Field Wiring Diagrams

Appendix D - Sensor Programming Table

Figures

Figure 1. Example TLS-450PLUS/8600 Console With TLS-XB Installation7
 Figure 2. Example TLS-3XX Console Installation8
 Figure 3. Example TLS2, TLS-50 And TLS-IB Installation9
 Figure 4. Example TLS RF Installation 10
 Figure 5. Example TLS4/8601 Console Installation 11
 Figure 6. TLS Terminal Box — Overall And Fixing Dimensions 12
 Figure 7. Zone 1 Mag Probe Installation with Process Connection (Gland) 14
 Figure 8. Veeder-Root 51mm And 76mm Riser Caps 16
 Figure 9. Example Mag Probe Riser Pipe Installation With Surge Protector 16
 Figure 10. Example Mag-FLEX Probe Wireless Installation 17
 Figure 11. Example Mag-FLEX Probe Hardwired Installation 17
 Figure 12. Example Mag Sump Sensor Installation 18
 Figure 13. Example Vacuum Sensor Installation 19
 Figure 14. Example DPLLD Installation 20
 Figure 15. Example Twin-Skin Piping Sump Installation 21
 Figure 16. Example Interstitial Sensor Installation In A Fibreglass Tank 22
 Figure 17. Example Interstitial Sensor Installation In A Steel Tank 23
 Figure 18. Example Sump Sensor Installation 24
 Figure 19. Example Dispenser Pan Sensor Installation 25
 Figure 20. Example Position-Sensitive Sump Sensor 26
 Figure 21. Example Containment Sump Sensor Installation 27
 Figure 22. Example Hydrostatic Sensor Installation 28
 Figure 23. Cross Section Through An Example Groundwater Sensor Installation ...30
 Figure 24. Cross Section Through An Example Vapour Sensor Installation31
 Figure 25. Example Discriminating Containment Sump Sensor Installation32
 Figure 26. Example Interstitial Sensor Installation - Fibreglass Tank33
 Figure 27. Example Interstitial MicroSensor Install - Steel Tank34
 Figure 28. Example MicroSensor Install - Riser Pipe 34

Tables

Table 1.	System Console Dimensions	6
Table 2.	Dimensions for Steel Riser Pipes and Mag Probe Floats	15
Table 3.	Probe Cable Specification (GVR P/N 222-001-0029) - Maximum Of 305 Metres Per Probe	37
Table 4.	Sensor Cable Specification (GVR P/N 222-001-0030) - Maximum Of 305 Metres Per Sensor	37
Table 5.	Data Transmission Cable Specification (GVR P/N 4034-0147)	38
Table 6.	Screened Multicore Cable - TLS Terminal Box To Console	38

Introduction

General

This document describes the procedures necessary to prepare the site, ready for the installation of the Veeder–Root TLS Series Liquid Storage Tank Monitoring Systems.

This manual does *not* cover the site preparation necessary for the installation of Veeder–Root Delivery Information Systems (DIS). For information on these products please refer to the relevant manuals for DIS-500, DIS-200 and DIS-50 systems.

Veeder–Root maintains a continuous process of product development and therefore product specifications may not be as described in this manual. Please contact the Veeder–Root office nearest you, or visit our website at www.veeder.com for information on new or updated products. Changes affecting products or procedures described in this manual will be reported in subsequent revisions. Veeder–Root has taken every care in the compilation of this manual; however it is the installers' responsibility to take every precaution to safeguard themselves and others.

Every person working with Veeder–Root equipment is expected to take every safety precaution possible and to have read this manual, particularly the sections referring to health and safety.

ATEX Safety Information provided in this manual is identical to Veeder–Root Manual No. 577013-578, the TLS Monitoring Systems Contractor's Site Preparation Guide. Local language versions of this manual are intended for use where ATEX Directive **2014/34/EU** applies.

NOTE Deviation from the specifications contained in this manual can result in rework, delays in system installation and additional installation charges.

Contractors are advised to contact their nearest Veeder–Root office where local conditions may preclude using the specifications contained in this manual.

Installation Levels

Veeder–Root or its Approved Installers may require that certain facilities are installed by contractors, nominated by the customer, prior to attending the site for the installation of a TLS system. These facilities vary dependent on the installation contract agreed between Veeder–Root or its Approved Installers, and the customer. Preparatory installation work is agreed between the customer and supplier.

Preparatory Work And Post Installation Work Usually Carried By The Customer/site Contractor

The contractor will install the following:

- Console power supply and earth
- High level alarm and associated wiring to TLS position. (supplied by Veeder–Root)
- External devices power supply and cabling
- Probe and sensor cable ducting
- Groundwater sensor wells
- Vapour sensor wells
- The contractor will seal all ducting after system testing has been carried out.

NOTE Unless stated otherwise, instructions in this manual refer to both levels of site preparation.

Preparatory Work And Post Installation Work Carried Out Either By the Customer/Site Contractor Or Monitoring System Installer

The customer or his elected contractor will supply (unless stated otherwise) and install the following:

- Console power supply and earth.
- High level alarm and associated wiring to TLS position. (supplied by Veeder-Root)
- External devices power supply and cabling (e.g. High level alarm)
- Peripheral devices cabling (e.g. data cables to pump controller and point-of-sale terminal)
- Probe and sensor cable ducting
- Probe field cables
- Probe risers
- Groundwater sensor wells
- Vapour sensor wells
- The contractor will seal all ducting after system testing has been carried out.

Product Description

SYSTEMS

Veeder-Root offer a comprehensive range of products designed to meet the needs of both large and small forecourt retailers. From stand alone gauging and leak detection systems, to fully integrated systems that can perform a wide range of functions including: tank gauging, automatic stock reconciliation, leak detection for double-skin tanks and precision tank testing.

All Veeder-Root systems have been designed for ease of operation. System consoles display information via a user interface or remote connection to guide the user through all operating functions. The status of all in-tank probes and leak detection sensors is available immediately on the user interface, on the system's printer or, through the system's communication facilities, on the point-of-sale terminal or back office computer.

IN-TANK PROBES

Magnetostrictive Probes are capable of performing precision tank testing (0.38 litres per hour and 0.76 litres per hour) when combined with the in-tank leak testing features of a TLS Console.

LEAK DETECTION SENSORS



- Sump Sensor - float sensor used for detecting liquids in dispenser sumps, tank lid access chambers and similar locations.
- Hydrostatic Sensor - a high and low level float sensor used to monitor the liquid in the interstice of double-skin liquid storage tanks. The sensor is supplied as an integral part of an interstitial fluid header tank which is located in the tank lid access chamber.
- Twin-Skin Pipe Interstitial Sensor- a float sensor used for detecting liquids within the interstice of twin-skin piping systems.
- Vapour Sensor - used to detect vapour in monitoring wells. The level of vapour detected is set on the system console, enabling background contamination to be accommodated. This sensor is used where the water table level is unreliable.
- Groundwater Sensor - detects liquid hydrocarbons on the water table in monitoring wells. The sensor is capable of detecting 2.5mm of free hydrocarbon on water. The sensor also alarms if the water table drops below the level where the sensor can no longer operate.
- Mag Sump Sensor - detects the presence and amount of water and/or fuel in the containment sump or dispenser pan. Using proven magnetostrictive technology to detect the hydrocarbons and water, the station (where allowed) remains in operation when water alone is detected. An alarm is also generated if the sensor has been moved from its proper position at the bottom of the sump or pan.

- Discriminating Dispenser Pan and Containment Sump Sensors - These discriminating sensors are installed in a dispenser pan or in a containment sump and will detect the presence of, and differentiate between, hydrocarbons and other liquids.
- Discriminating Interstitial Sensor for double-skin fibreglass tanks - The Discriminating Interstitial Sensor for double-skin fibreglass tanks uses solid-state liquid level sensing technology to detect liquid in the interstitial space of the tank. The sensor can differentiate between hydrocarbons and other liquids. An open sensor triggers a Sensor Out alarm.
- MicroSensor - The non-discriminating small, easy to install solid-state MicroSensor is designed detect liquid in the interstitial space of a steel tank or a fill riser containment. An open sensor triggers a Sensor Out alarm.
- Secondary Containment Vacuum Sensor - detects leaks in double-skin tanks and piping systems while helping to contain a release of product while under vacuum. Vacuum sensors, connected to tank, sump or piping interstices and a Submersible Turbine Pump (STP) (vacuum source) are connected to a TLS-350 console via intrinsically safe wiring. Alarms when vacuum cannot be maintained or when replenish rate exceeds 85 litres per hour or if liquid is detected in the secondary space.
- Pressurised Line Leak Detection (PLLD) - consists of a pressure transducer and SwiftCheck valve (not required for all pump types) installed in the leak detector port of a submersible turbine pump, two console plug-in modules in the TLS-350 console, and patented measurement software to test the product line at full pump pressure for highly accurate 0.38 lph precision and 11.3 lph gross testing.
- Digital Pressurised Line Leak Detection (DPLLD) - consists of a digital pressure transducer and SwiftCheck valve (not required for all pump types) installed in the leak detector port of a submersible turbine pump, connects to the USM module in the TLS-450/8600 or TLS-450PLUS/8600 console and TLS-XB box, and is used with patented measurement software to test the product line at full pump pressure for highly accurate 0.38 lph precision and 11.3 lph gross testing.

Health And Safety

SAFETY SYMBOLS

The following safety symbols are used throughout this manual to alert you to important safety hazards and precautions.

 <p>Explosive Fuels and their vapors are extremely explosive if ignited.</p>	 <p>Read All Related Manuals Knowledge of all related procedures before you begin work is important. Read and understand all manuals thoroughly. If you do not understand a procedure, ask someone who does</p>
 <p>WARNING Heed the adjacent instructions to avoid equipment damage or personal injury.</p>	

GENERAL



Ensure that all local council and E.C. laws and regulations are complied with. Also ensure that all recognised safety codes are followed.

NOTE Every person working with Veeder–Root equipment is expected to take every safety precaution possible in the installation of the TLS Systems.

Contractors must ensure that supervisory personnel on the installation site are aware of their presence and requirements, especially the provision of safe working areas and isolation from AC electrical power.

Leaking liquid storage tanks can create serious environmental and health hazards. It is the contractor's responsibility to comply with the instructions and warnings found in this manual.

DANGER AREAS

 WARNING	
	<p>TLS System products will be operated near the highly combustible environment of a fuel storage tank. FAILURE TO COMPLY WITH THE FOLLOWING WARNINGS AND SAFETY PRECAUTIONS COULD CAUSE DAMAGE TO PROPERTY, ENVIRONMENT, RESULTING IN SERIOUS INJURY OR DEATH.</p>
	<p>Failure to install these products according to the instructions contained in this manual may result in explosion and personal injury.</p> <p>It is essential that the warnings and instructions in this manual are carefully read and followed to protect both the installer and others from serious or fatal injury.</p>

If the liquid storage tank to be fitted with a TLS system either contains or at any time has contained petroleum products then the tank inspection chamber must be considered a hazardous environment as defined in IEC/EN 60079-10 Classification of Hazardous Areas. Suitable working practices for this environment must be observed.

General Overview Of The ATEX Directive

ASSOCIATED APPARATUS

The Veeder-Root TLS (Tank Level System) Consoles are installed in an indoor, non hazardous area. The consoles have barriers that protect the linked apparatus by an **[Exia]** intrinsically safe mode of protection and are suitable to control apparatus installed into areas that are likely to become hazardous in the presence of concentrations of gases, vapours or mists formed by group **IIA** dangerous substances. The symbols on the nameplate have the following meaning:

	Device suitable to be installed in potentially explosive areas
II	Group II: for installations in areas other than mines and related surface equipment
(1)	Category 1: suitable to control apparatus installed into Zone 0, Zone 1 or Zone 2 hazardous areas
G	For potentially hazardous areas characterised by the presence of gases, vapours or mists

All ATEX models of **TLS Consoles** are in compliance with ATEX Directive **2014/34/EU**.

A sample Console has been evaluated and tested by **UL International Demko A/S** P.O. Box 514 Lyskaer 8, DK-2730 Herlev, Denmark and approved by the issue of the EC type certificates:

- DEMKO 11 ATEX 111659X** for TLS4/8601 Consoles
- DEMKO 07 ATEX 16184X** for TLS-450/8600, TLS-450PLUS/8600 Consoles
- DEMKO 06 ATEX 137481X** for TLS-350 & TLS-350R Consoles
- DEMKO 06 ATEX 137484X** for TLS-300 Consoles
- DEMKO 06 ATEX 137485X** for TLS-50, TLS2, TLS-IB Consoles
- DEMKO 12 ATEX 1204670X** for TLS-XB/8603 Consoles

INTRINSICALLY SAFE APPARATUS

The Veeder-Root MAG Probes and Sump Sensors and Pressurized Line Leak Sensors are intrinsically safe apparatus, marked **Ex ia**, suitable for installation into areas that are likely to become hazardous in the presence of concentrations of gases, vapours or mists formed by group **IIA** dangerous substances. The temperature class of

the devices is **T4** (surfaces temperatures lower than 135°C). The symbols on the nameplate have the following meaning:

	Device suitable to be installed in potentially explosive areas
II	Group II: for installations in areas other than mines and related surface equipment
1	Category 1: Intrinsically Safe Apparatus installation into Zone 0, Zone 1 or Zone 2 hazardous areas
G	For potentially hazardous areas characterised by the presence of gases, vapours or mists

All ATEX models of **Probes, Vapour and Pressure Sensors** are in compliance with ATEX Directive **2014/34/EU**.

A sample has been evaluated and tested by **UL International Demko A/S** P.O. Box 514 Lyskaer 8, DK-2730 Herlev, Denmark and approved by the issue of the EC type certificates:

DEMKO 06 ATEX 0508841X for MAG probes and Mag Sump sensors
DEMKO 07 ATEX 141031X for DPLLD Line Liquid Leak Detection sensors
DEMKO 06 ATEX 137486X for Pressure Line Liquid Leak Detection sensors
DEMKO 07 ATEX 29144X for Vacuum Sensors
DEMKO 06 ATEX 137478X for TLS Radio Transmitter
DEMKO 13 ATEX 1306057X for Surge/I.S. Circuit Protector

A sample has been evaluated and tested by TUV NORD CERT GmbH, Hanover Office Am TUV1 30519 Germany and approved by the issue of the EC type certificate:

TUV 12 ATEX 105828 for MAG Flex Probes

Symbol X used as suffix in all of the EC type test certificates listed above indicates the need for observing special conditions for safe use. Further information is provided in each respective EC type certificate under the paragraph 17.

Quality System

	Equipment marking is compliant with requirements in the CE Marking Directive.
---	---

The manufacturers Quality System has been reviewed and is notified by *SGS Baseefa Staden Lane, Buxton, Derbyshire, SK17 9RZ, United Kingdom* authorizing the use of its ID **1180** in conjunction with the CE mark. The manufacturer is notified via SGS Baseefa QAN No. BASEEFA ATEX 1968. The CE mark may indicate compliance with other relevant EC directives. Consult the manufacturers EC Declarations of Conformity for details.

Surge Protectors

In a Veeder-Root system, each intrinsically safe (I.S.) device may use an optional surge protector in place of the weatherproof junction box located in Zone 1. Surge/ protectors consist of a certified in-line device or a simple apparatus conforming to the requirements of Standard No. IEC/EN 60079-14, Electrical installations design, selections and erection. See input electrical data table in Appendix A for ratings and restrictions.

Surge Protectors are: ATEX Certified Devices as  II 2 G Ex ia IIA T4 Gb per Certificate No. DEMKO 13 ATEX 1306057X; IECEx Certified Devices rated **Ex ia IIA T4 Gb** per Certificate No. IECEx UL 13.0074X; and are designated IP68 Simple Apparatus.

NOTE When installing (in-tank) MAG Probes using a process connection, a surge protector is not required. Prior to installing a MAG probe in a tank using a riser pipe, perform a risk assessment to determine exposure to electrical surges. If exposure to surges is possible, install an appropriate surge protection device. A surge protector is mandatory for wireless (RF) MAG probe installations.

System Consoles

Console Location

The system console should be located on an inside wall of the forecourt building at a height of 1500mm from the floor. Figure 2 through Figure 4 and Figure 5 show typical console installation arrangements.

The equipment is designed to operate safely under the following range of conditions:

- Altitude up to 2000m.
- Temperature range - see Table 1.
- A maximum relative humidity of 95% RH (non-condensing) at temperatures shown in Table 1.
- Main supply voltage fluctuations not exceeding $\pm 10\%$
- Pollution Degree Category 2, Installation Category 2

NOTE Consoles are not suitable for external locations and must be installed within the interior of buildings.

Ensure that the console is located where neither the console nor its associated cabling will be damaged by doors, furniture, barrows, etc.

Consider the ease of routing wiring, ducting and probe cables to the console.

Check that the mounting surface material is strong enough to support the console.

NOTE If the unit requires cleaning, do not use any liquid materials (e.g. cleaning solvents). It is recommended that the unit be wiped with a clean dry cloth when necessary.

Console Dimensions

Overall dimensions and the weight of the various system consoles are as shown in Table 1:

Table 1. System Console Dimensions

System	Temperature Range	Height	Width	Depth	Weight	ATEX Descriptive System Document	IECEX Descriptive System Document
TLS-450/8600, TLS-450PLUS/8600	$0^{\circ} \leq T_a \leq 40^{\circ}C$	331mm	510mm	225mm	15kg	331940-006	331940-106
TLS-350R / Plus	$0^{\circ} \leq T_a \leq 40^{\circ}C$	331mm	510mm	190mm	15kg	331940-001	331940-101
TLS-300	$0^{\circ} \leq T_a \leq 40^{\circ}C$	331mm	510mm	110mm	10kg	331940-002	331940-102
TLS-50, TLS-IB	$0^{\circ} \leq T_a \leq 40^{\circ}C$	163mm	188mm	55mm	2.3kg	331940-003	331940-103
TLS2	$0^{\circ} \leq T_a \leq 40^{\circ}C$	163mm	188mm	105mm	2.3kg	331940-003	331940-103
TLS-RF Accessories	$0^{\circ} \leq T_a \leq 40^{\circ}C$	163mm	188mm	55mm	2.3kg	331940-005	331940-105
TLS4/8601	$0^{\circ} \leq T_a \leq 50^{\circ}C$	221mm	331mm	92mm	2.9kg	331940-017	331940-117
TLS-XB/8603	$0^{\circ} \leq T_a \leq 50^{\circ}C$	331mm	248mm	212mm	10kg	331940-020	331940-120

To allow for maintenance ensure that the console is in an accessible area, even when the console doors are open. Ensure that all relevant subcontractors and other personnel are aware of the selected location. The system console is installed by Veeder-Root authorised engineers.

Power Requirements

It is recommended that console power come from a dedicated circuit via a fused, switched, neon indication spur within one metre of the console position. The spur must be clearly marked to identify it as the means for disconnecting the console.

NOTE Console power supply wiring must comply with local electrical regulations.

For each external device, such as a forecourt alarm, a separate switched, neon indication spur fused to the correct rating must be supplied.

From an independent 24-hour supply at the distribution panel, run three 2.0mm² (minimum) standard colour coded wires, live, neutral and earth, to the fused spur.

Run one wire having a cross sectional area of 4mm², colour coded green/yellow, from the earth bus bar at the distribution panel direct to the Console location. Leave at least 1 metre of free cable for connection to the console.

Console Installation Examples

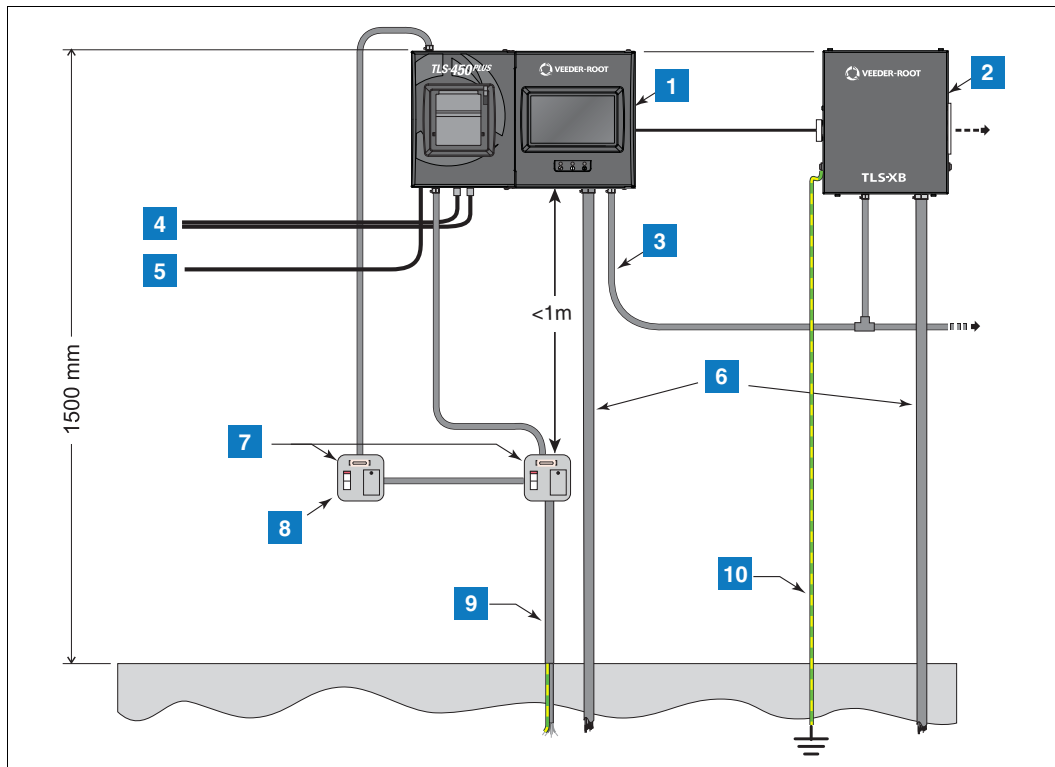

Figure 1. Example TLS-450PLUS/8600 Console With TLS-XB Installation

LEGEND FOR NUMBERED BOXES IN Figure 1

- | | |
|---|--|
| 1. TLS-450PLUS | 7. 5A fused, switched, neon spurs |
| 2. TLS-XB Box (optional) - Up to 3 TLS-XB boxes can be connected to a TLS-450PLUS | 8. Required for optional external device |
| 3. Multicore to pump contactors | 9. Dedicated power supply and Earth ground |
| 4. Communication cables | 10. Earth ground |
| 5. Cable to high level alarm | |
| 6. Probe/sensor field cables | |

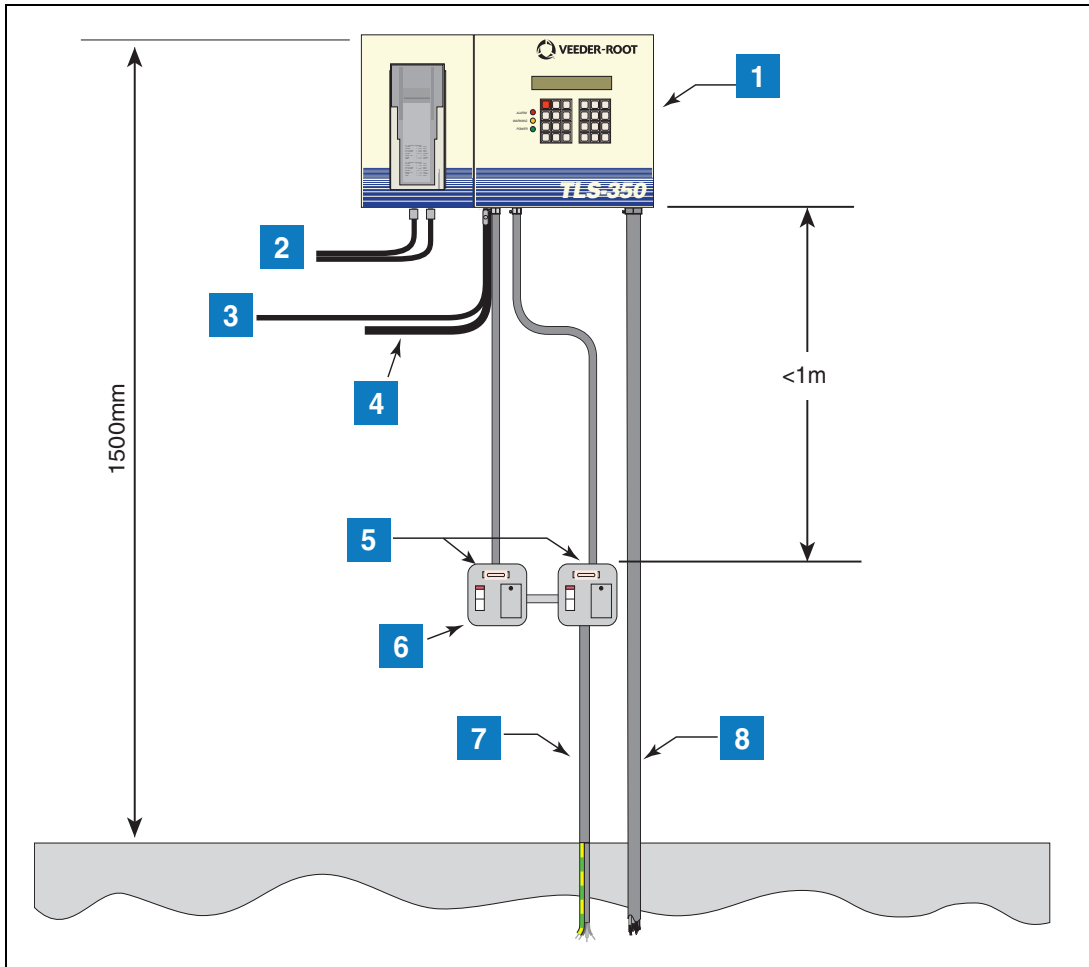

Figure 2. Example TLS-3XX Console Installation

LEGEND FOR NUMBERED BOXES IN Figure 2

- | | |
|-----------------------------------|--|
| 1. TLS-350 | 6. Required for optional external device |
| 2. Communication cables | 7. Dedicated power supply and Earth ground |
| 3. Cable to high level alarm | 8. Probe/sensor field cables |
| 4. Multicore to pump contactors | |
| 5. 5A fused, switched, neon spurs | |

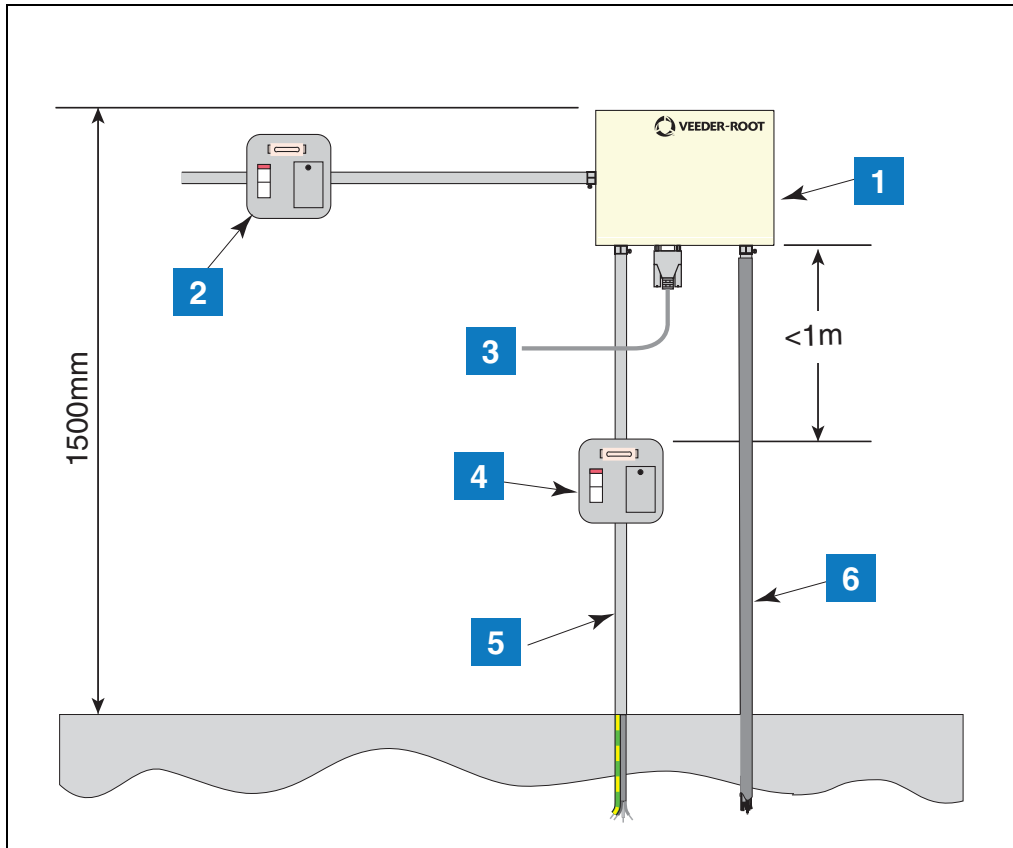

Figure 3. Example TLS2, TLS-50 And TLS-IB Installation

LEGEND FOR NUMBERED BOXES IN Figure 3

- | | |
|---|--|
| 1. TLS Console | 5. Dedicated power supply and Earth ground |
| 2. Fused, switched, neon spur (required for optional external device) | 6. Probe/sensor field cables |
| 3. Communication cable | |
| 4. 5A fused, switched, neon spur | |

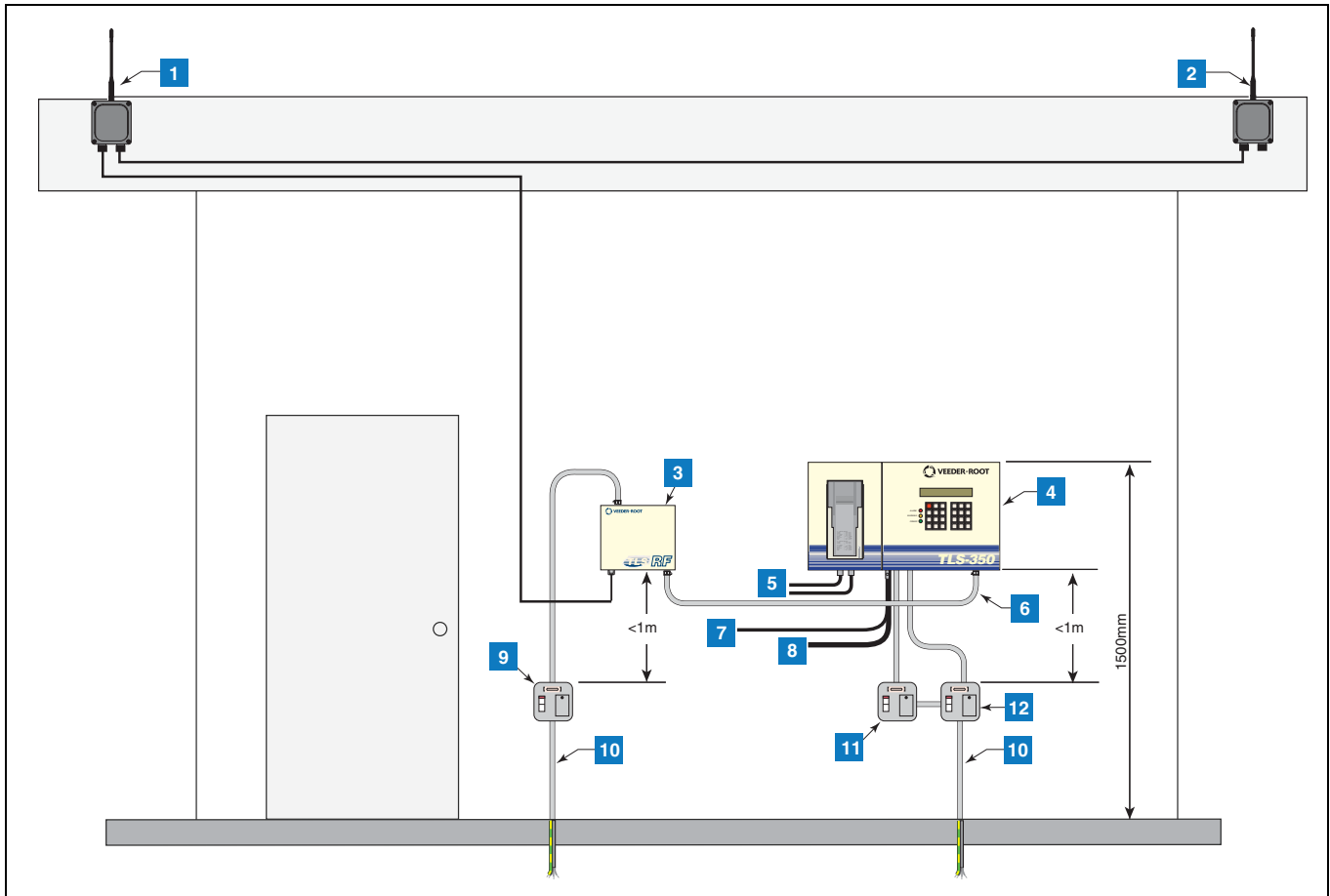

Figure 4. Example TLS RF Installation

LEGEND FOR NUMBERED BOXES IN Figure 4

- | | |
|------------------------------------|---|
| 1. TLS RF Receiver | 8. Multicore to pump contactors |
| 2. TLS RF Repeater | 9. 5A fused, switched, neon spur |
| 3. TLS RF | 10. Dedicated power supply and Earth ground |
| 4. TLS Console | 11. Required for optional external device |
| 5. Communication cables | 12. 5A fused, switched, neon spur |
| 6. TLS Console Probe input signals | |
| 7. Cable to high level alarm | |

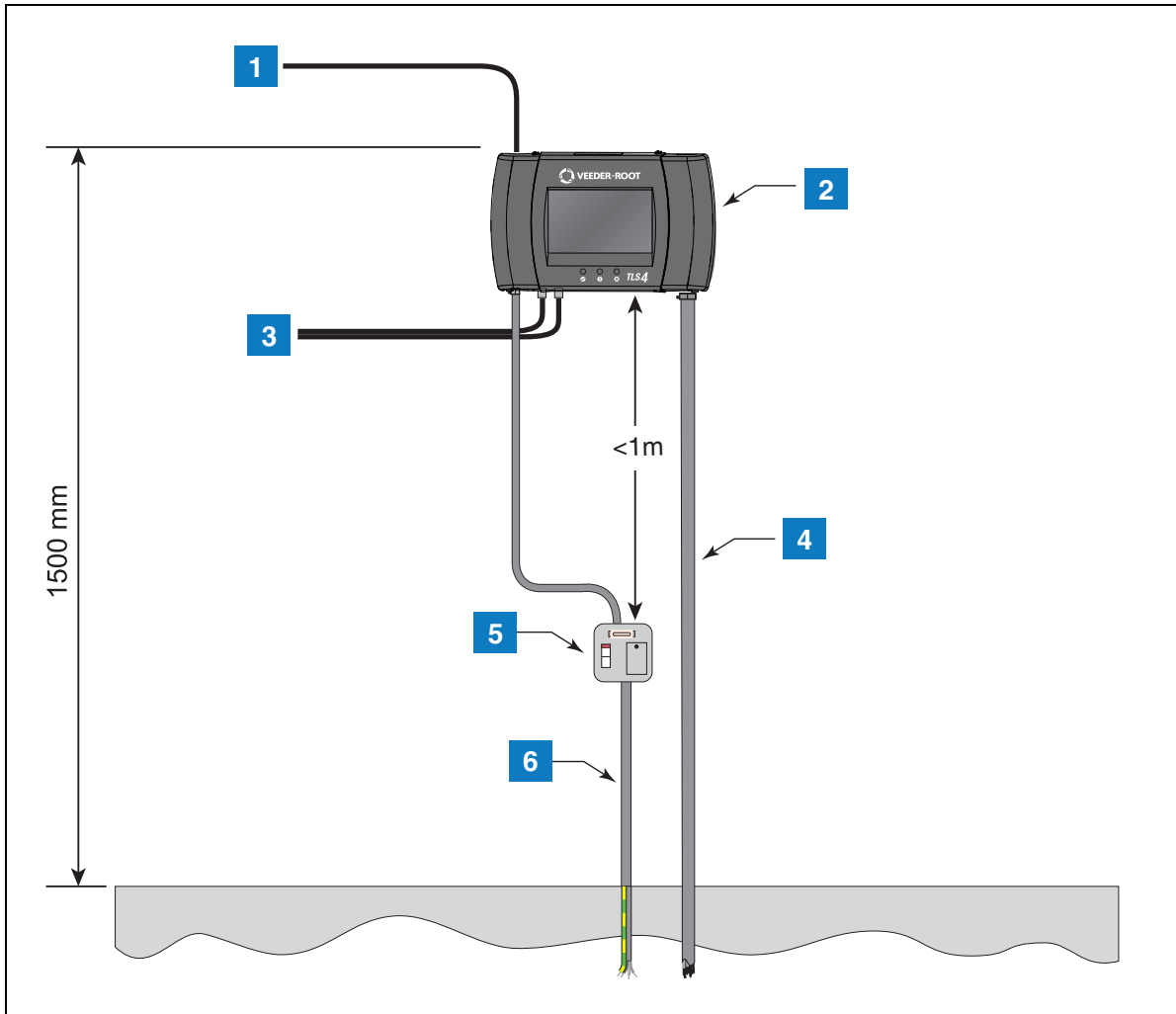

Figure 5. Example TLS4/8601 Console Installation

LEGEND FOR NUMBERED BOXES IN Figure 5

- 1. Cable to high level alarm
- 2. TLS4/8601 Console
- 3. Communication cables
- 4. Probe/sensor field cables
- 5. 5A fused, switched, neon spur
- 6. Dedicated power supply and Earth ground

TLS Terminal Box Location, If Required

Veeder–Root recommend that the field wiring is run directly to the TLS console. However, if a terminal box is used, it should be mounted on an inside wall of the forecourt building at a practical level, adjacent to the field wiring ducting entry.

Connection to the system console is made by Veeder-Root engineers.

NOTE The cable route from the TLS terminal box location to the system console location must not exceed 15 metres.

Ideally the terminal box should be placed on the same wall and within 2 metres of the system console.

Be sure the terminal box will be protected from vibration, extremes in temperature and humidity, rain and other conditions that could cause equipment malfunction.

Ensure that the terminal box is not located where either the console or its associated cabling will be damaged by doors, furniture, barrows, etc.

Where TLS terminal boxes are to be installed by the contractor the specified units will be shipped to the site prior to the installation and commissioning of the TLS system.

Check the mounting surface material is strong enough to support the terminal box.

Overall and fixing dimensions are given in Figure 6.

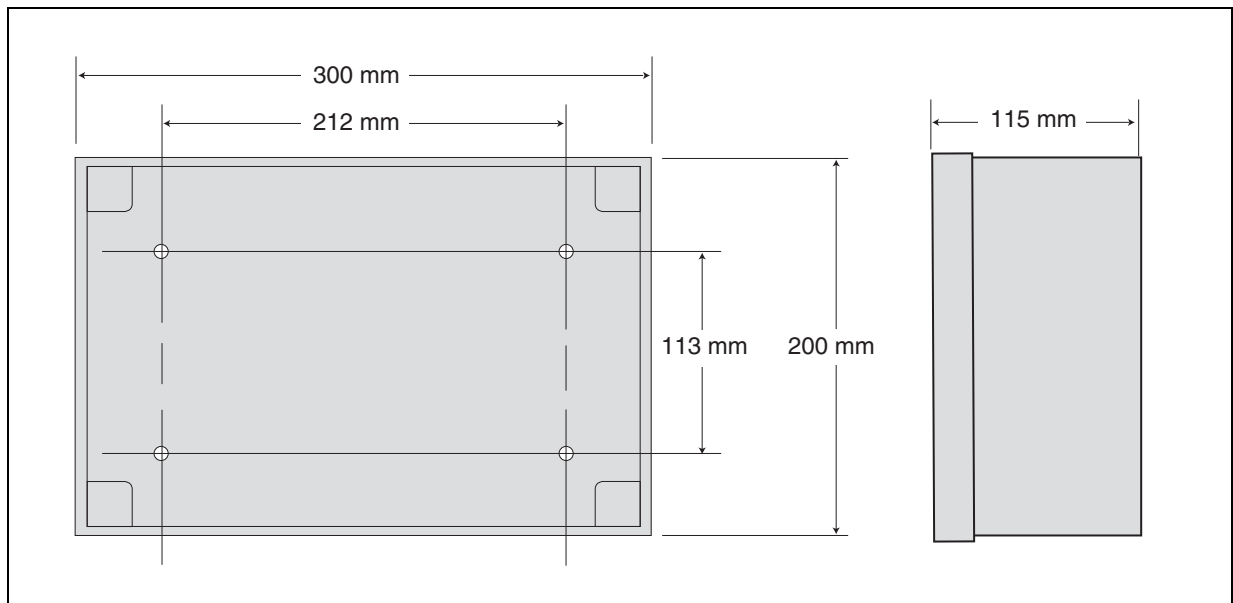

Figure 6. TLS Terminal Box – Overall And Fixing Dimensions

Intrinsically Safe Apparatus

Mag Probe Installations

MAG PROBE INSTALLATION USING A PROCESS CONNECTION

A suitable process connection, IP67 minimum, is required for sealing a tank riser pipe or for forming an appropriate boundary wall. The process connection gland can be supplied by Gilbarco Veeder-Root and is included on the manufactures type approval certificates DEMKO 06 ATEX 0508841X and IECEx UL 06.0001X. The 501-000-1206 process connection provides IP67 zone isolation and has been additionally subjected to a 10 bar pressure test.

Certain installations may require a modified probe mounting arrangement consisting of a process connection (gland) mounted directly to the tank lid as shown in Figure 7. Either a dedicated tapping or a suitable flange, tapped G2 inch 11 threads per inch to DIN 2999 (BS2779) must be provided. Prior to installing or servicing the Magnetostrictive Probe, remove the AC input power going to the TLS Console and verify that the console power is off. During servicing, disconnect the probe cable and remove the probe from the tank.

1. Reference Figure 7 to identify the hardware required to complete this installation.
2. Install the flange onto the tank lid then install the gland adapter. For 3-inch and 4-inch float sizes, install the tube gland and the associated reducer onto the gland adapter prior to performing Step 4.
3. Prior to inserting the Mag Probe, install the tube gland on the probe shaft near the probe canister. Care must be taken to ensure that the probe shaft is not harmed in any way.
4. Add the fuel float and the water float then install the plastic boot on the very bottom of the probe.
5. Insert the probe assembly into the tank and tighten the tube gland to the gland adapter.
6. Slide the Mag probe downward until the boot makes contact with the tank bottom. Lift the probe at least 10 mm (0.4 inch) from the bottom of the tank to account for thermal expansion of the probe. Tighten the tube gland once the probe is at the appropriate height.
7. Connect the probe leader cable to the field wiring using a weatherproof junction box or an optional dual-channel surge protector (P/N 848100-002) as shown in Figure 7.
8. Restore power to the TLS Console and verify that the system is operating properly.

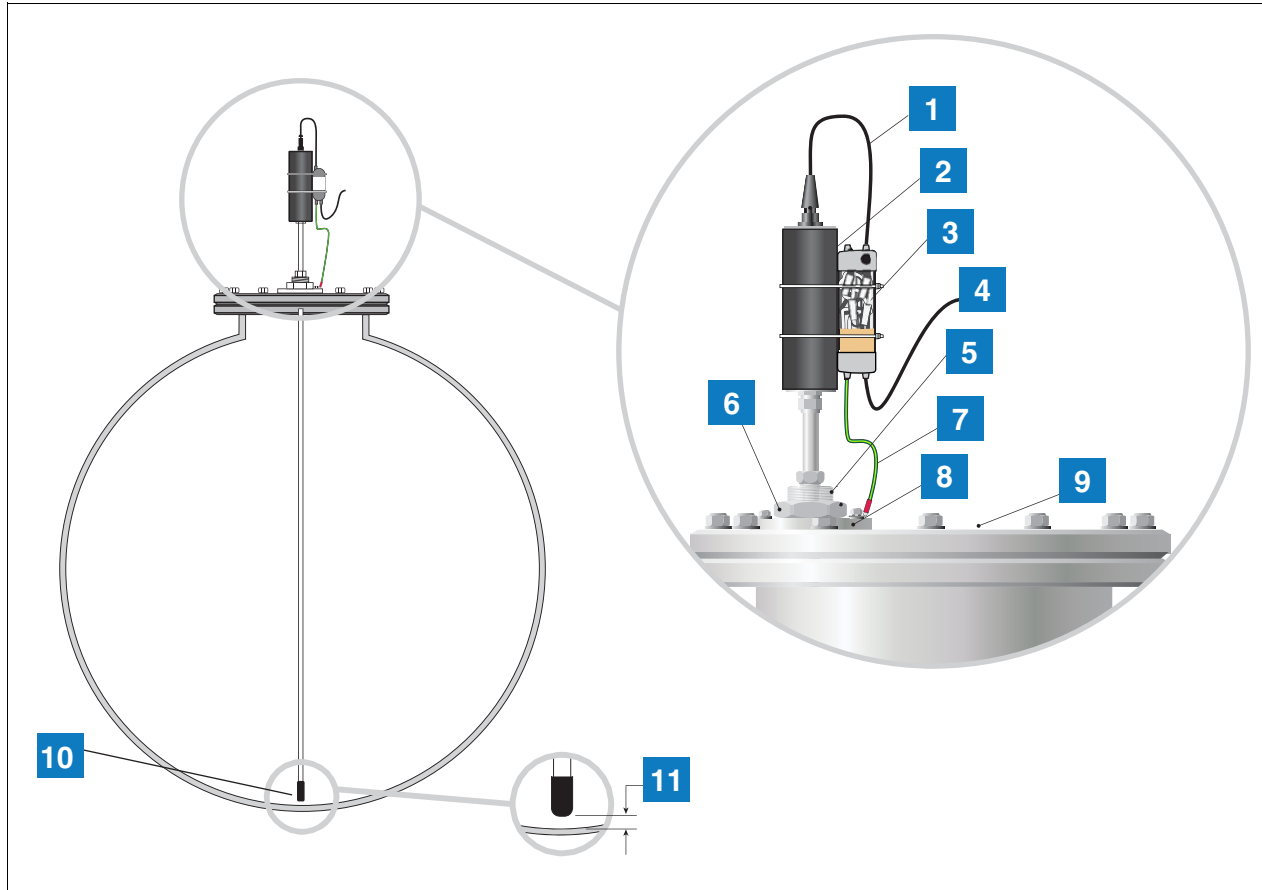

Figure 7. Zone 1 Mag Probe Installation with Process Connection (Gland)

LEGEND FOR NUMBERED BOXES IN Figure 7

- | | |
|--|---|
| 1. Probe leader cable | 7. Ground wire (4mm ² cross-sectional area) from surge protector to tank |
| 2. Probe canister | 8. Flange |
| 3. Optional Dual-channel surge protector (P/N 848100-002) | 9. Tank lid |
| 4. Field cable to console | 10. Boot |
| 5. 1-inch BSP to 2-inch BSP reducer included with 501-000-1207 kit | 11. 10mm (0.4") Minimum gap |
| 6. Custom steel flange adapter | |

MAG PROBE RISER PIPE INSTALLATIONS

2-Inch And 3-Inch Risers

A riser assembly consisting of a riser (either 2- or 3-inch [50.8 or 76mm] nominal bore galvanised steel pipe threaded 2- or 3-inch BSPT at each end) and a 2- or 3-inch riser cap, designed specifically for the efficient installation of Veeder-Root magnetostrictive probes, should be used for Mag Probe installation (see Figure 8).

NOTE Where locally supplied, 2-inch risers shall be seamless, have a 2-inch ID, and be free of burrs.

The canister of the probe must be completely contained within the riser with the probe shaft resting on the bottom of the tank. Risers, when fitted, should be a minimum of 100mm above the probe canister.

Non-standard or locally supplied risers may be made from 2- or 3-inch nominal bore galvanised steel pipe threaded 2- or 3-inch at each end (see Table 2 for allowable riser dimensions).

Remove the plug from the tank socket. Install a 2-inch (50mm nominal bore) or 3-inch (80mm nominal bore) riser using an appropriate thread-sealing compound. Reducers are available for 4-inch (102mm nominal bore) sockets. If the probes are not to be installed immediately, cap the riser.

1-Inch Risers

Mag probe installations in 1-inch risers will be custom installations since the probe canister is 51mm in diameter. The use of 1-inch risers will require special adapters and a process connection and will be subject to local regulatory approval.

Table 2. Dimensions for Steel Riser Pipes and Mag Probe Floats

DN Nom Pipe (mm)	NPS Nom Pipe (inch)	ID Nom Pipe (mm)	ID Nom Pipe (inch)	OD Max Float (mm)	OD Max Float (inch)	OD Min Float (mm)	ID Max* Pipe (mm)
25	1	26.65	1.049	29.34	1.155	29.08	N/A
50	2	52.51	2.067	47.63	1.875	46.86	55
80	3	77.93	3.068	76.58	3.015	75.82	85
100	4	102.26	4.026	95.63	3.765	94.87	110

DN = Diameter Nominal, NPS = Nominal pipe size, Pipe type is iron or schedule 40 steel - *Maximum allowable inside diameter for Mag Probe installation.

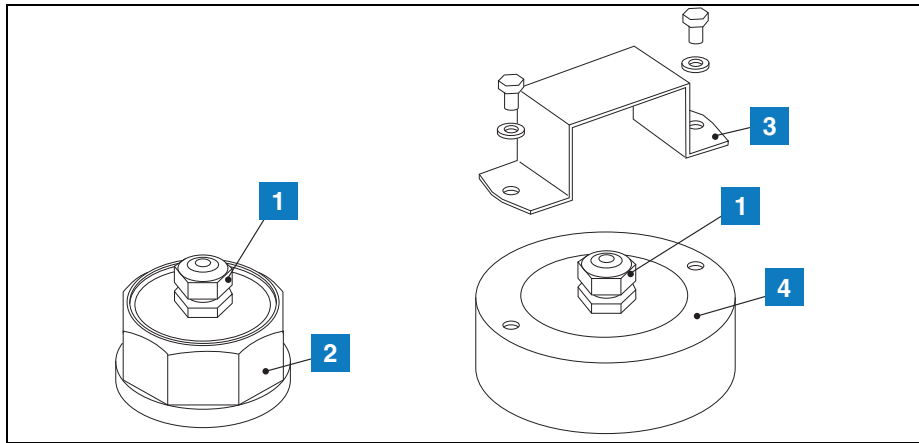

Figure 8. Veeder-Root 51mm And 76mm Riser Caps

LEGEND FOR NUMBERED BOXES IN Figure 8

- | | |
|--|--|
| <ul style="list-style-type: none"> 1. Hummel probe leader cable gland P/N: HSK-M-Ex, Size: M16X1,5 (IP68) , Ratings: Ex 11 2G 10 IP68 2. 51mm (2-inch) threaded galvanised steel riser cap | <ul style="list-style-type: none"> 3. Shield (if required) 4. 76mm (3-inch) BSP riser cap (use fitting tool 705-100-3033 to install or remove the cap) |
|--|--|

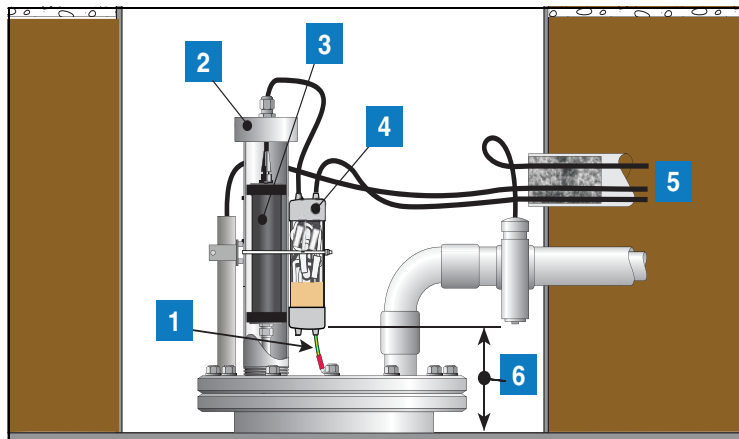

Figure 9. Example Mag Probe Riser Pipe Installation With Surge Protector

LEGEND FOR NUMBERED BOXES IN Figure 9

- | | |
|---|--|
| <ul style="list-style-type: none"> 1. Ground wire (4mm² cross-sectional area) from surge protector to tank 2. 76mm BSP riser cap with Hummel probe leader cable gland P/N: HSK-M-Ex, Size: M16X1,5 (IP68) , Ratings: Ex 11 2G 10 IP68 3. Mag probe in riser | <ul style="list-style-type: none"> 4. Dual-channel surge protector (P/N 848100-002) 5. Sealed ducting with field cables to TLS console 6. Install surge protector within 1m of tank entry |
|---|--|

MAG-FLEX PROBE INSTALLATIONS

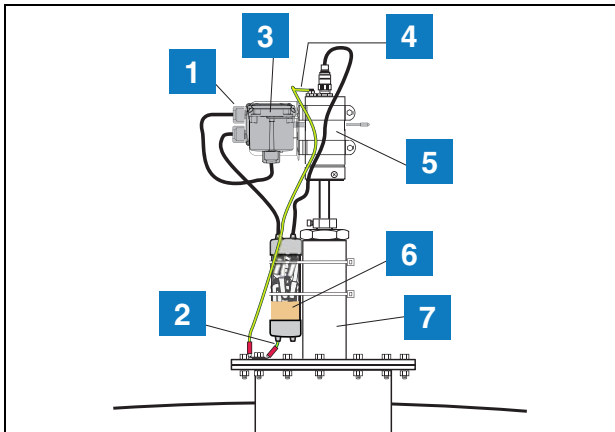

Figure 10. Example Mag-FLEX Probe Wireless Installation

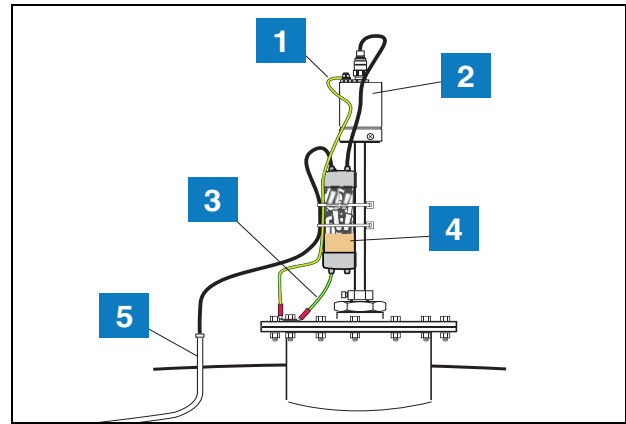

Figure 11. Example Mag-FLEX Probe Hardwired Installation

LEGEND FOR NUMBERED BOXES IN Figure

1. TLS RF Transmitter (attached to side of bracket)
2. Ground wire (4mm² cross-sectional area) from surge protector to tank
3. Battery pack (in bracket)
4. Ground wire (4mm² cross-sectional area) from probe canister to tank
5. Mag-FLEX probe canister
6. Single-channel surge protector (P/N 848100-001)
7. Riser pipe

LEGEND FOR NUMBERED BOXES IN Figure 11

1. Ground wire (4mm² cross-sectional area) from probe canister to tank
2. Mag-FLEX probe canister
3. Ground wire (4mm² cross-sectional area) from surge protector to tank
4. Dual-channel surge protector (P/N 848100-002)
5. Sealed ducting with field cable to TLS console

Mag Sump Sensor

NOTE Make sure there is no liquid present in the pan/sump before installing sensor

The Mag Sump Sensor (Form No. 857080-XXX) must rest in the lowest point of the pan or sump and completely compress the position indicator to avoid causing a ‘Sensor Out’ alarm (see Figure 12). The sensor should be mounted such that you can pull the sensor straight out of the pan/sump if service is required.

Access wells are recommended for dispenser sumps and other similar situations where access to the sensor may be restricted.

NOTE Customers should note that the use of access wells reduces maintenance times and consequently site downtime. Ducting entry points to all containment sumps and monitoring wells must be sealed *after system testing* to prevent both the escape of either hydrocarbon vapour or liquid and to prevent the ingress of water.

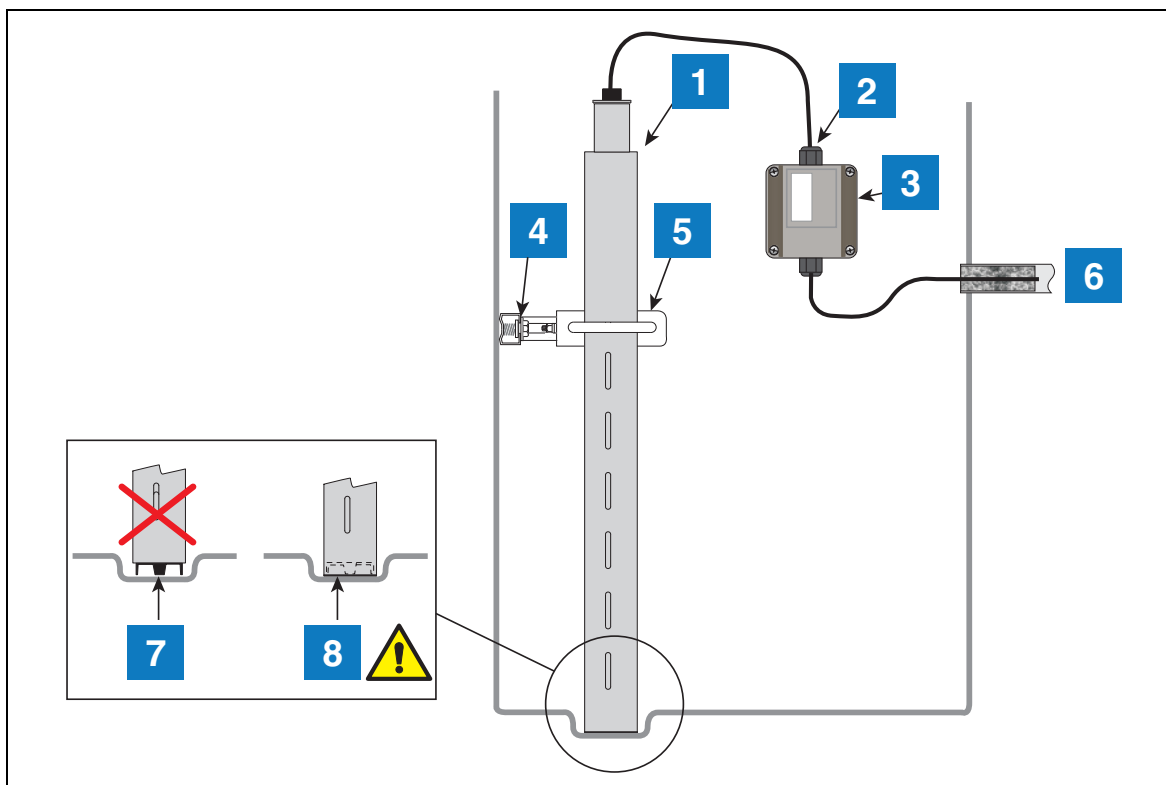

Figure 12. Example Mag Sump Sensor Installation

LEGEND FOR NUMBERED BOXES IN Figure 12

- | | |
|---|--|
| <ul style="list-style-type: none"> 1. Sensor 2. Cord grip 3. Weatherproof junction box 4. U-channel 5. Brackets, clamp, etc., from optional Universal Sensor Mounting kit 6. Sealed ducting with field cable to TLS console | <ul style="list-style-type: none"> 7. Incorrect mounting - sensor housing off bottom leaving position indicator extended in its alarm position 8. Correct mounting - IMPORTANT! Sensor housing must rest on bottom of the sump to prevent a ‘Sensor Out’ alarm. |
|---|--|

Vacuum Sensor

Figure 13 shows an example Vacuum Sensor (Form No. 332175-XXX) installation in a submersible turbine pump (STP) double-skin sump.

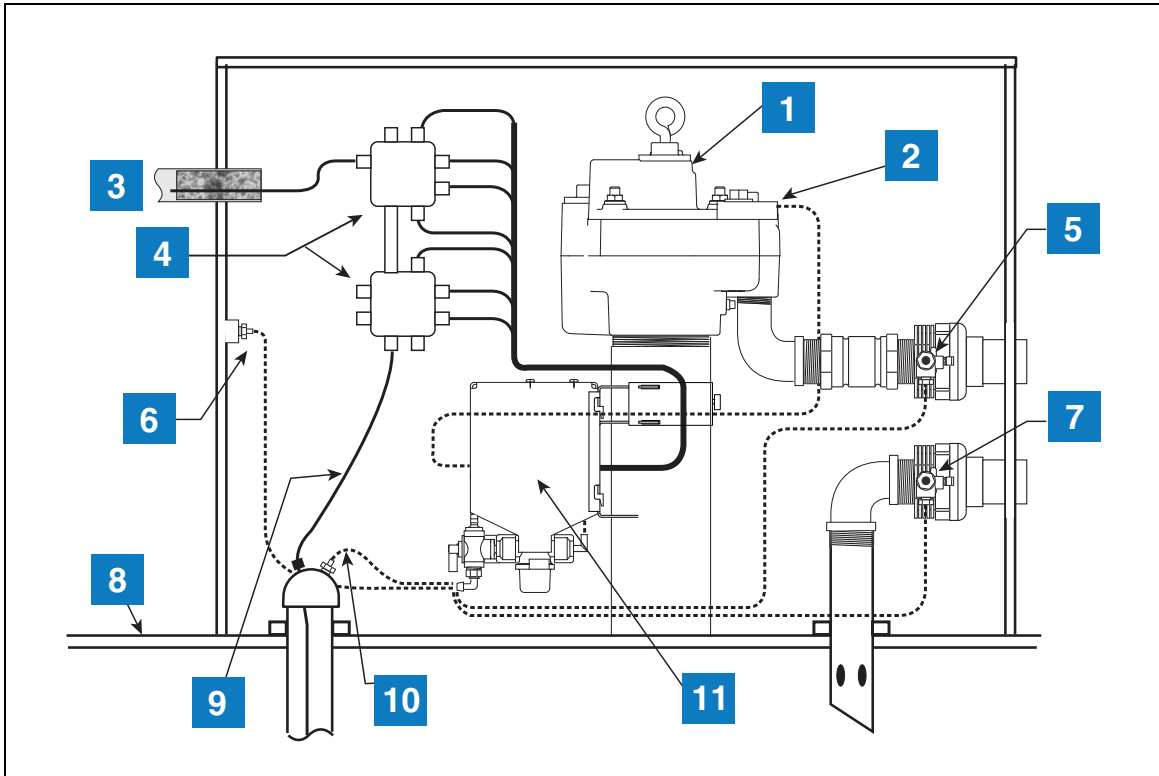

Figure 13. Example Vacuum Sensor Installation

LEGEND FOR NUMBERED BOXES IN Figure 13

- | | |
|---|--|
| 1. STP | 7. Vapor return line vacuum fitting |
| 2. Barbed fitting in siphon port for vacuum source | 8. Double-skin tank |
| 3. Sealed ducting with field cable to TLS console | 9. Wiring from sensor in tank interstice connects to vacuum sensor in junction box |
| 4. Dual weatherproof junction boxes w/cord grip wiring entries containing epoxy sealed connections | 10. Tank interstitial sensor vacuum fitting |
| 5. Product line vacuum fitting | 11. Four Vacuum Sensor Housing Assembly - bracketed to riser |
| 6. Double-skin sump vacuum fitting - If multiple ports are provided in the sump wall, install vacuum fitting in lowest one. | |

DPLLD Transducer

Figure 14 shows an example Digital Pressurised Line Liquid Leak Detector (DPLLD) transducer (Form No. 8590XX-XXX) installed in a submersible turbine pump (STP).

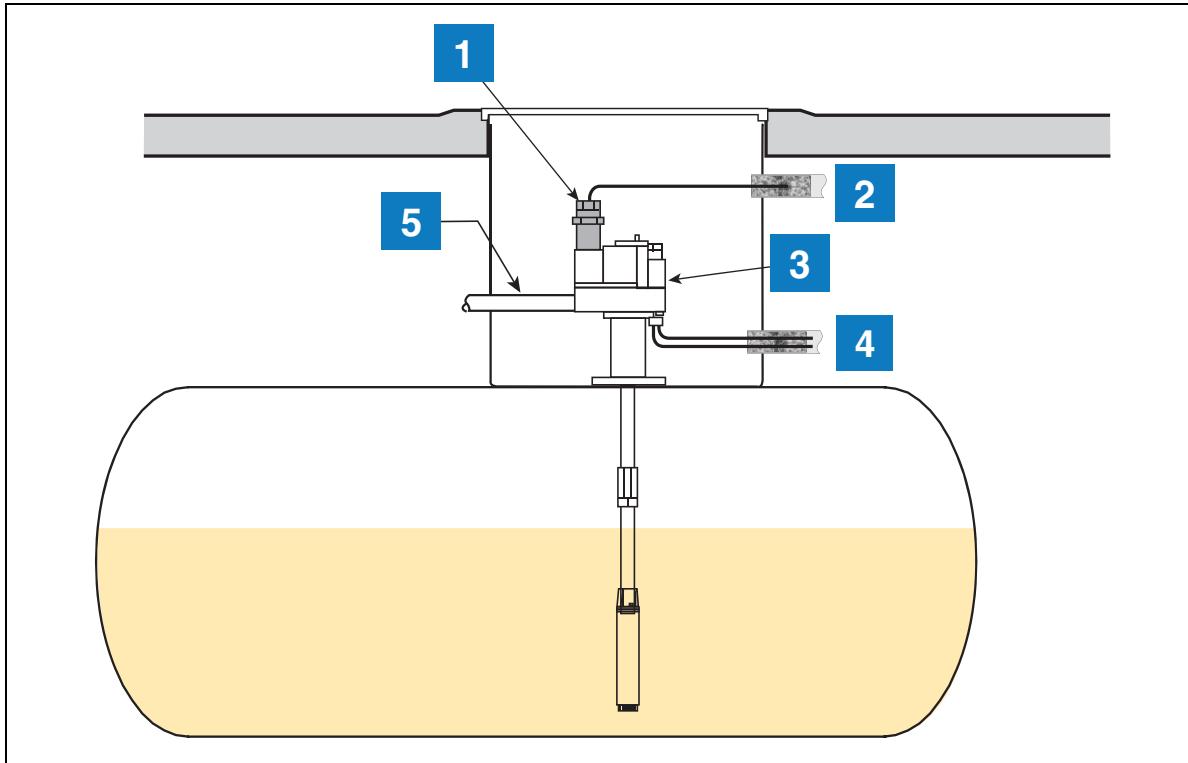

Figure 14. Example DPLLD Installation

LEGEND FOR NUMBERED BOXES IN Figure 14

- | | |
|---|---------------------------------------|
| 1. DPLLD transducer | 4. Sealed ducting to pump control box |
| 2. Sealed ducting with field cable to TLS console | 5. Product piping to dispensers |
| 3. STP | |

Twin-Skin Piping Sump

A sump of no less than 50mm internal diameter must be provided at the lowest point of the outer pipe. The sump must be constructed so that any liquid in the pipe interstice will flow directly to the sump. Figure 15 shows an example sump fabricated from standard pipe fittings. The sump riser must provide an external 2-inch (51mm) BSP thread for the fitting of a Veeder-Root gland cap.

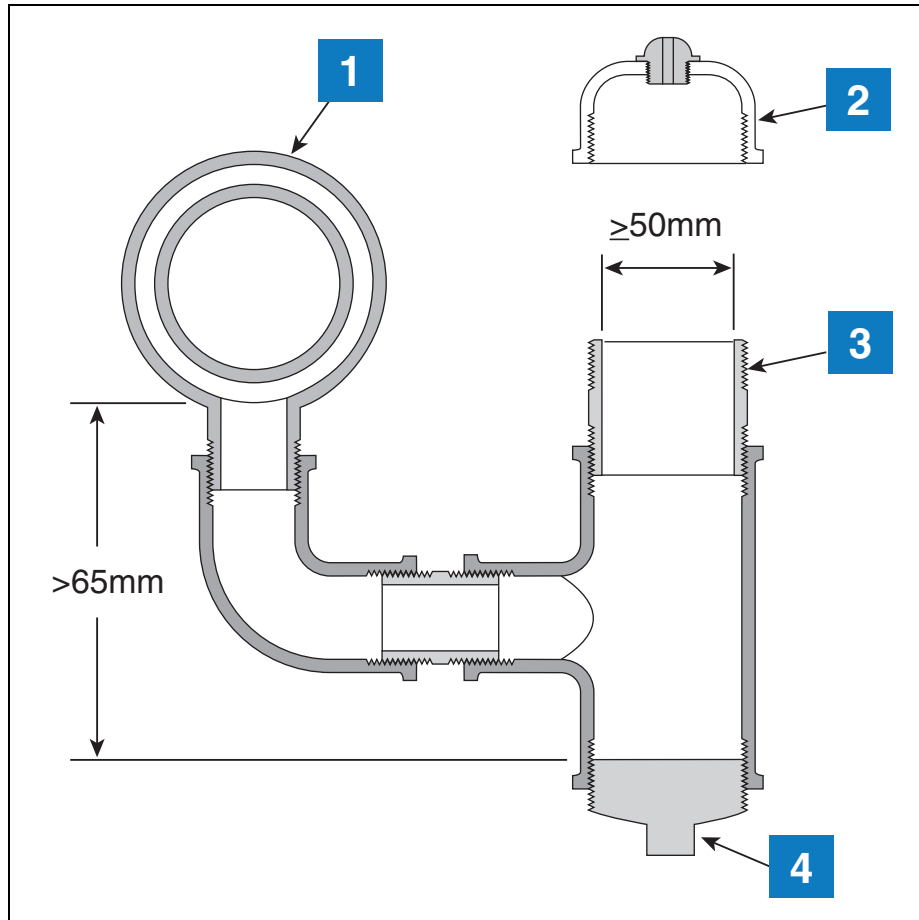

Figure 15. Example Twin-Skin Piping Sump Installation

LEGEND FOR NUMBERED BOXES IN Figure 15

- | | |
|--|--|
| 1. Double-skin pipe | 3. Sump riser to be externally threaded to fit standard 2" BSP cap |
| 2. Cap and cable gland supplied by Veeder-Root | 4. Plug or cap |

Interstitial Sensors

Figure 16 shows an example installation of an Interstitial Sensors (Form Nos. 794380-40X).

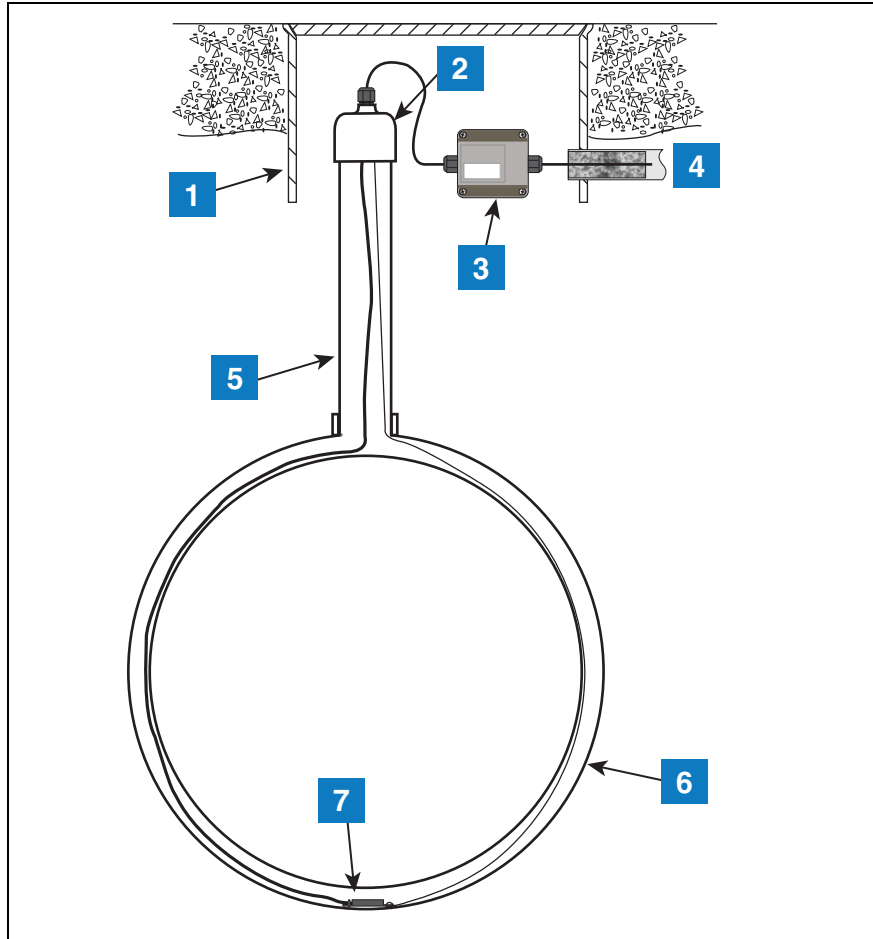

Figure 16. Example Interstitial Sensor Installation In A Fibreglass Tank

LEGEND FOR NUMBERED BOXES IN Figure 16

- | | |
|--|---|
| 1. Appropriate reducer with 1/2" NPT opening for cable cord grip | 4. 100mm diameter riser |
| 2. Weatherproof junction box with cord grips | 5. Fibreglass tank |
| 3. Sealed ducting with field cable to TLS console | 6. Sensor switch must rest on bottom of tank interstice |
| | 7. Sensor cable |

Steel Tank Sensors

Figure 17 shows an example installation of a Position Sensitive Interstitial steel tank sensor (Form Nos. 794380-X3X).

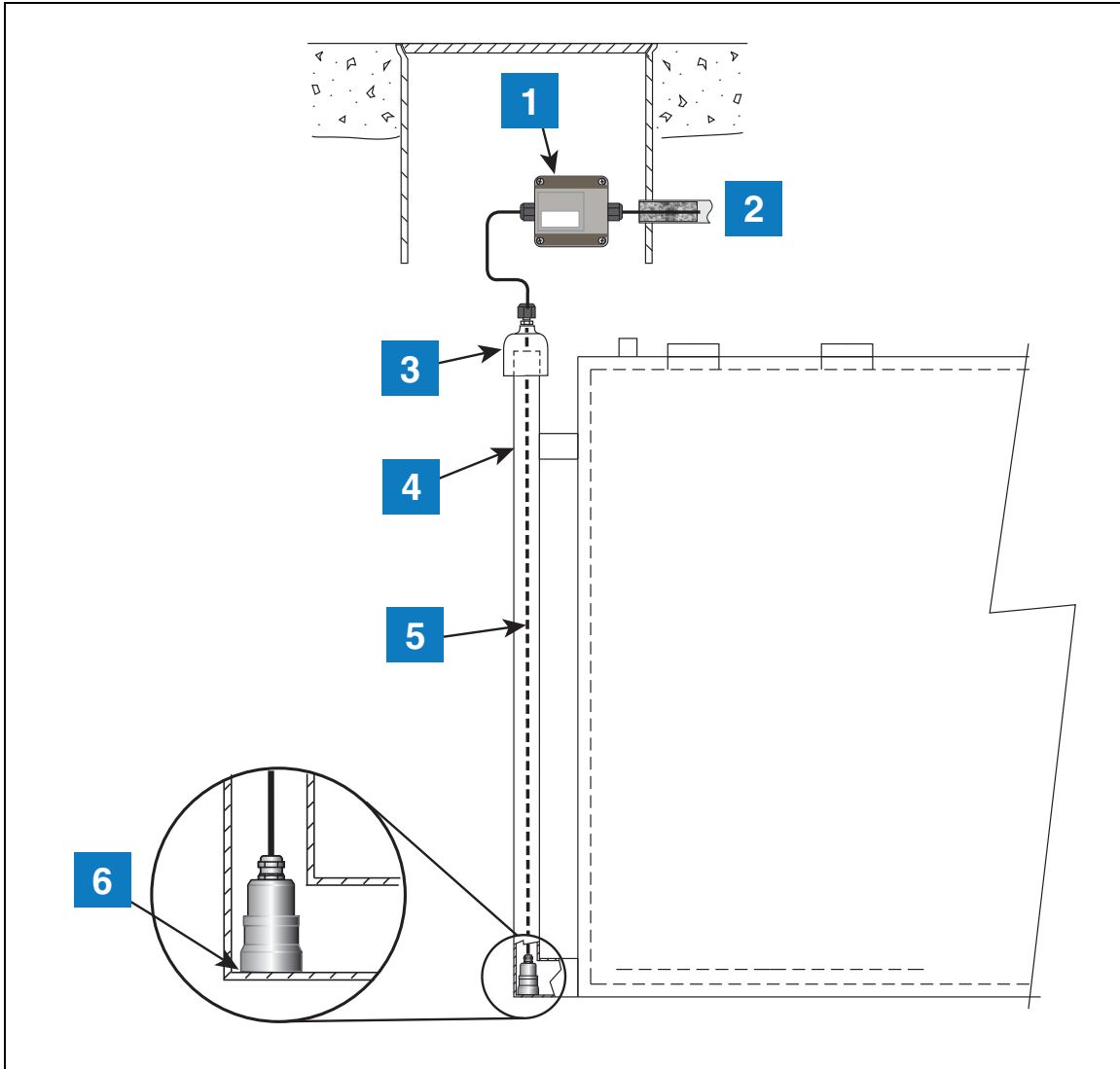

Figure 17. Example Interstitial Sensor Installation In A Steel Tank

LEGEND FOR NUMBERED BOXES IN Figure 17

- | | |
|--|---|
| 1. Weatherproof junction box with cord grips | 4. Minimum 50mm diameter interstitial riser pipe |
| 2. Sealed ducting with field cable to TLS console | 5. Sensor leader cable |
| 3. Appropriate reducer with 1/2" NPT opening for cable cord grip | 6. Sensor switch must rest on bottom of interstitial riser pipe |

Sump Sensors

Figure 18 shows an example installation of a Sump Sensor (Form Nos. 794380-208).

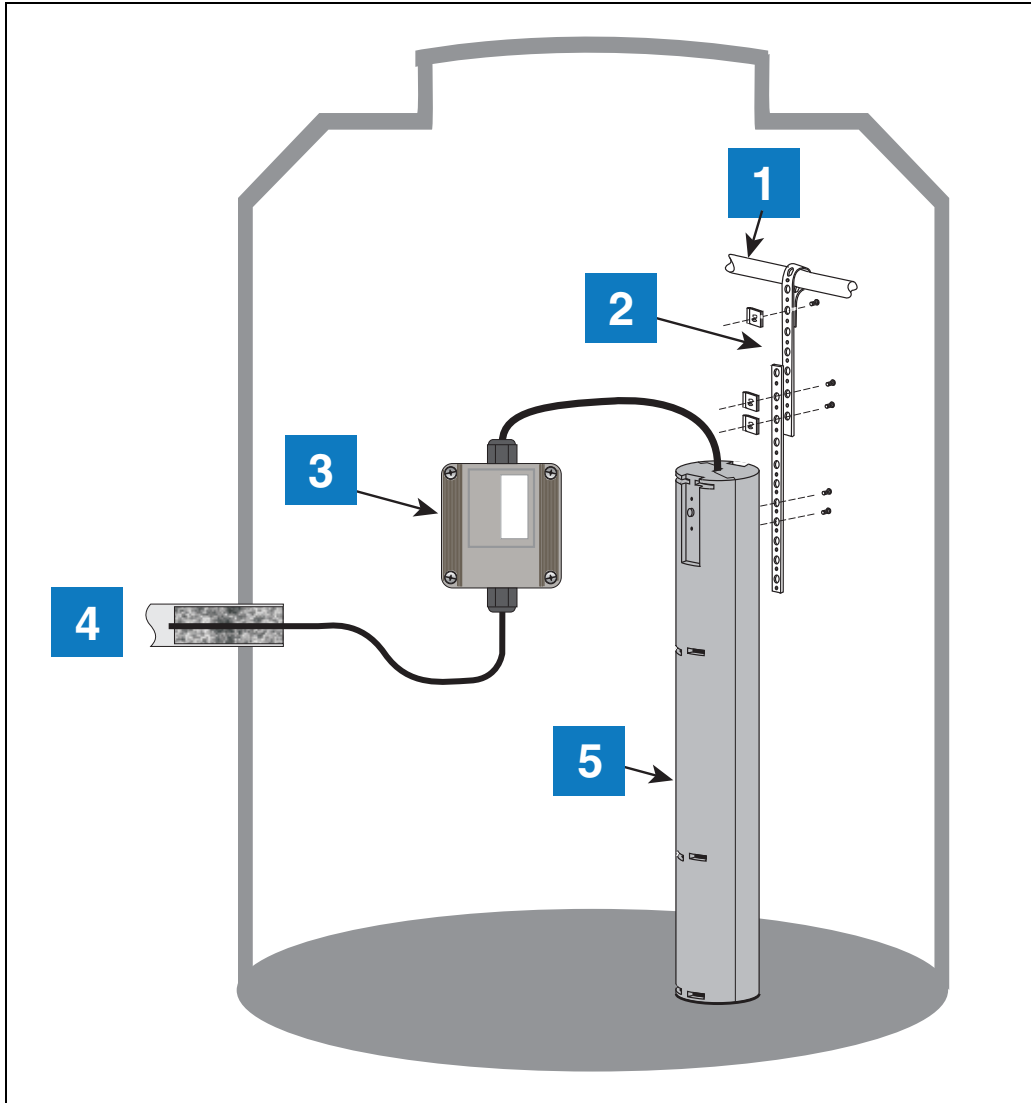

Figure 18. Example Sump Sensor Installation

LEGEND FOR NUMBERED BOXES IN Figure 18

- | | |
|--|---|
| <ol style="list-style-type: none"> 1. Existing piping in sump 2. Appropriate parts from optional Universal Sensor Mounting kit 3. Weatherproof junction box and cord grips 4. Sealed ducting with field cable to TLS console | <ol style="list-style-type: none"> 5. Sump sensor should: <ul style="list-style-type: none"> • Rest on the base of the sump • Be positioned as close to the outer wall as possible • Be mounted in a true vertical position • Be installed only in a dry sump |
|--|---|

Dispenser Pan Sensors

Figure 19 shows an example installation of a Dispenser Pan Sensor (Form Nos. 794380-3XX).

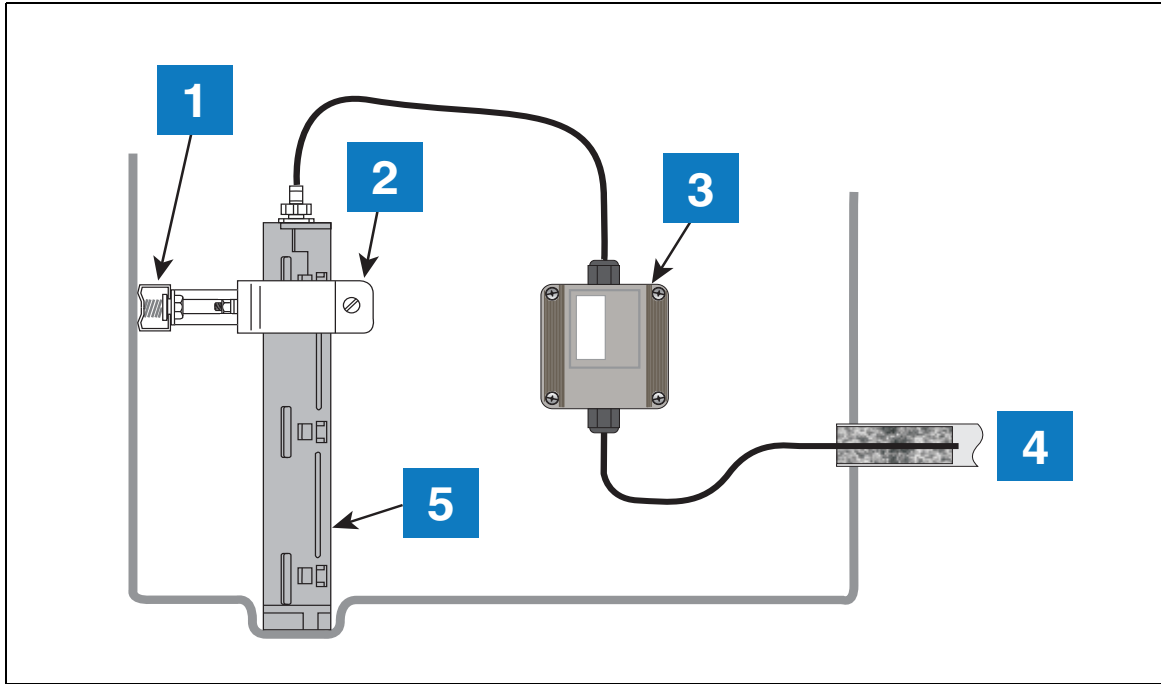

Figure 19. Example Dispenser Pan Sensor Installation

LEGEND FOR NUMBERED BOXES IN Figure 19

1. Sump U-channel
2. Brackets, clamp, etc., from optional Universal Sensor Mounting kit
3. Weatherproof junction box with cord grips
4. Sealed ducting with field cable to TLS console
5. Dispenser pan sensor should:
 - Rest in the cup or the lowest point of the dispenser pan
 - Be positioned so as to be removable by pulling the sensor straight up out of the pan
 - Be mounted in a true vertical position

Position-Sensitive Sensors

Figure 20 shows an example installation of a Position-Sensitive sump sensor (Form Nos. 794380-323).

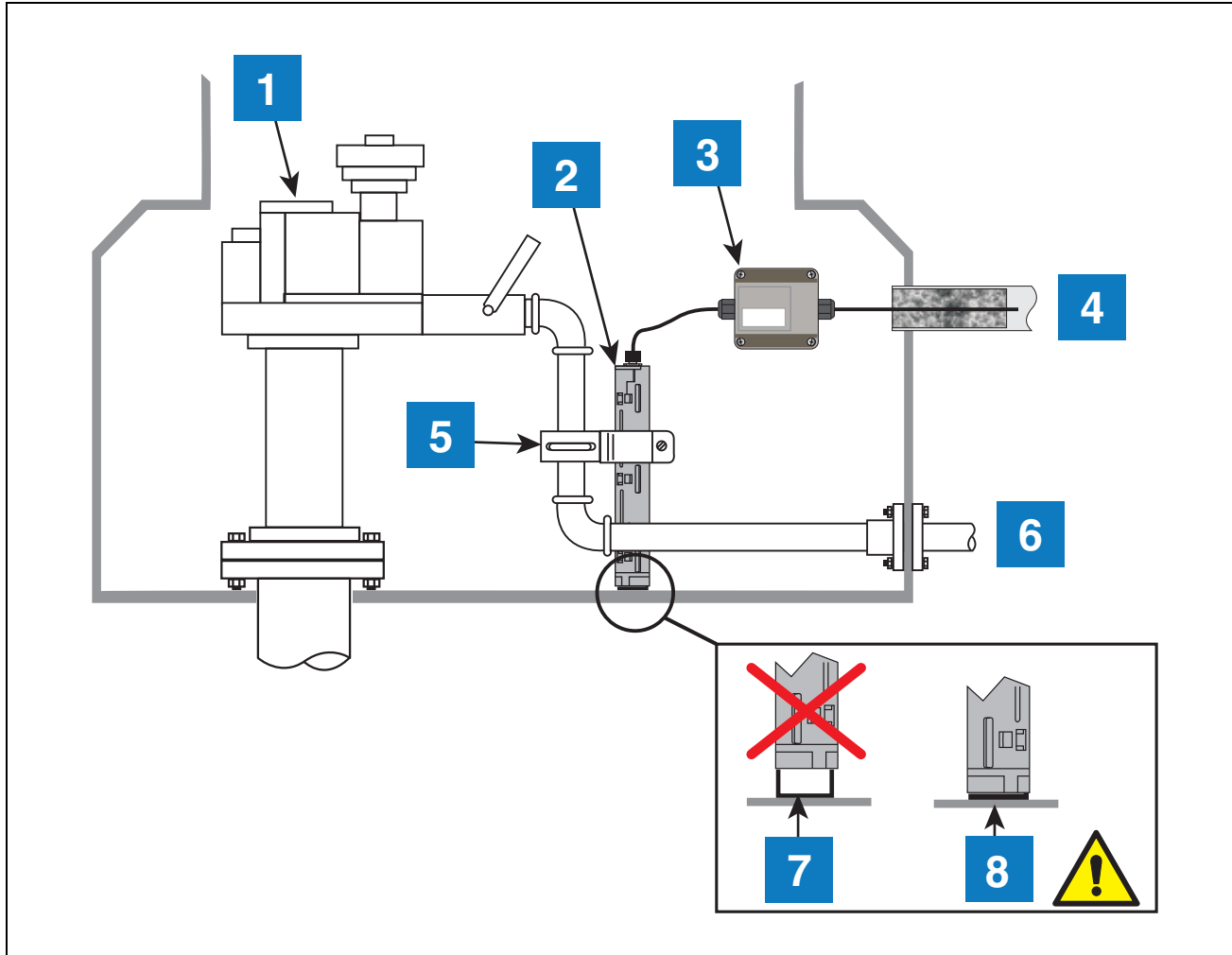

Figure 20. Example Position-Sensitive Sump Sensor

LEGEND FOR NUMBERED BOXES IN Figure 20

- | | |
|--|--|
| <ol style="list-style-type: none"> 1. Submersible Turbine Pump 2. Sensor - IMPORTANT! do not mount sensor to a flexible product line. 3. Weatherproof junction box with cord grips 4. Sealed ducting with field cable to TLS console 5. Brackets, clamp, etc., from optional Universal Sensor Mounting kit | <ol style="list-style-type: none"> 6. Product line to dispenser 7. Incorrect mounting - sensor housing off bottom leaving position indicator extended in its alarm position 8. Correct mounting - IMPORTANT! Sensor housing must rest on bottom of the sump to prevent a 'Sensor Out' alarm. |
|--|--|

Containment Sump Sensors

Figure 21 shows an example installation of a Containment Sump Sensor (Form Nos. 794380-3X1).

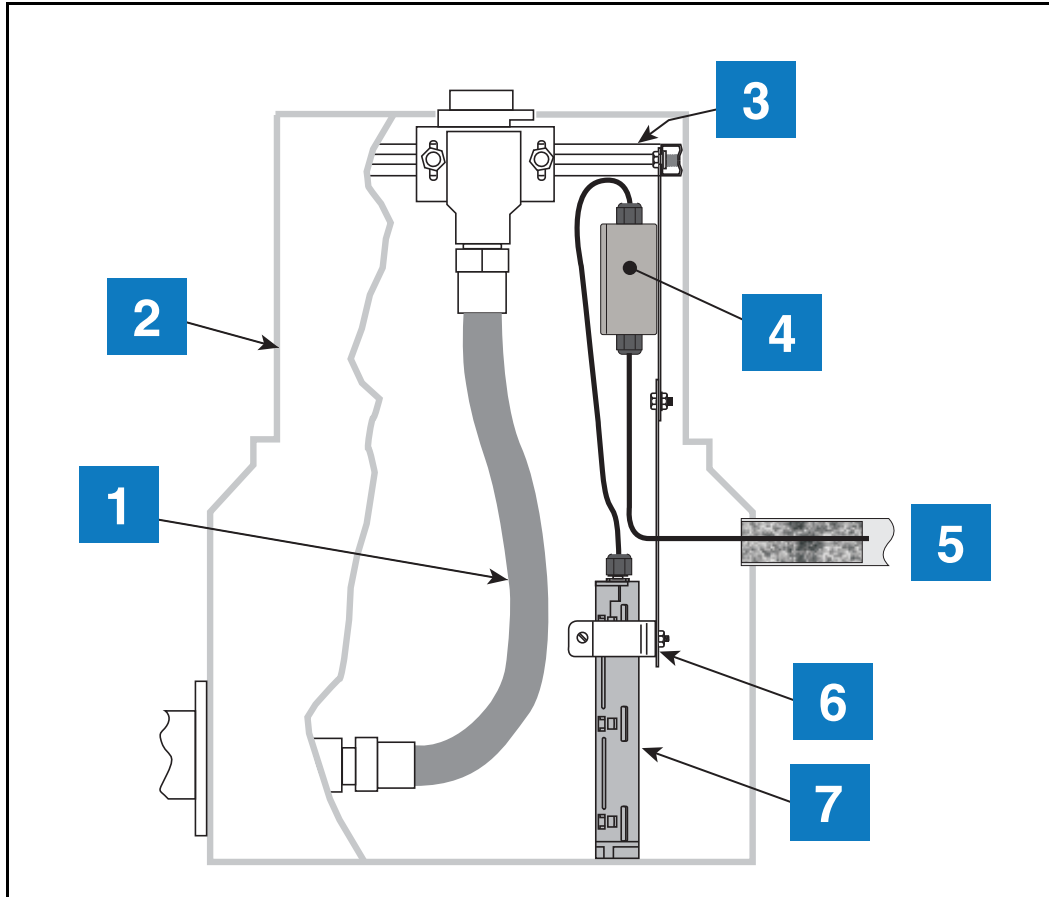

Figure 21. Example Containment Sump Sensor Installation

LEGEND FOR NUMBERED BOXES IN Figure 21

1. Flexible product line - **CAUTION! Do not mount sensor to a flexible product line.**
2. Sump
3. Sump U-channel
4. Weatherproof junction box with cord grips
5. Sealed ducting with field cable to TLS console
6. Brackets, clamp, etc., from optional Universal Sensor Mounting kit
7. Containment sump sensor should:
 - Rest in the cup or the lowest point of the containment sump
 - Be positioned so as to be removable by pulling the sensor straight up out of the pan
 - Be mounted in a true vertical position

Hydrostatic Sensors

Figure 22 shows an example installation of a Hydrostatic Sensor (Form Nos. 794380-30X).

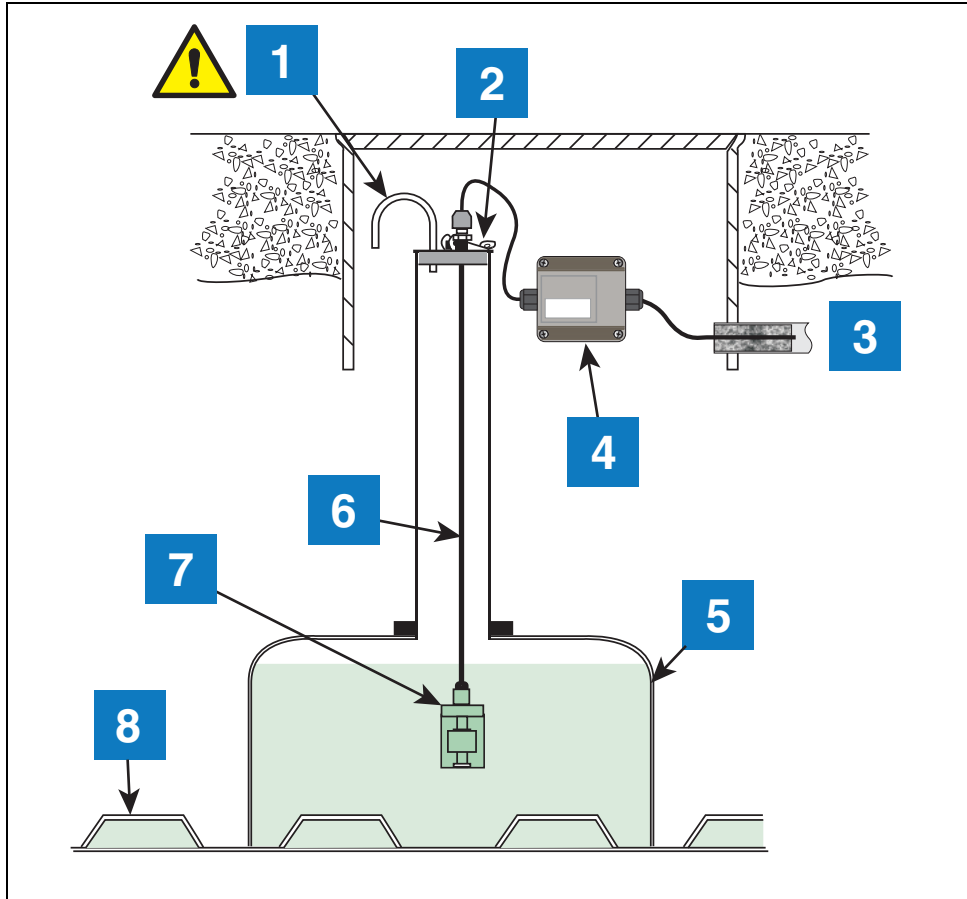

Figure 22. Example Hydrostatic Sensor Installation

LEGEND FOR NUMBERED BOXES IN Figure 22

- | | |
|---|------------------------------------|
| 1. Vent tube - CAUTION! Tube must remain clear | 5. Monitoring fluid reservoir |
| 2. Riser pipe cap with cord grip | 6. Adjustable lead cable |
| 3. Weatherproof junction box with cord grips | 7. Single-point hydrostatic sensor |
| 4. Sealed ducting with field cable to TLS console | 8. Double-skin tank |

Monitoring Wells

To ensure the maximum efficiency of Veeder–Root Groundwater and Vapour Sensors Veeder–Root strongly recommends that wells for the installation of vapour or groundwater sensors are constructed in accordance with the following specifications.

All materials are proprietary items and are readily available.

NOTE These are recommendations only. Contractors should ensure that all wells conform to all regulations and codes of practice in force for the installation locality.

All monitoring wells should extend to 1000mm below the level of the lowest tank or pipework system.

The well must be capped and protected from traffic with a suitable access chamber and cover. The top of the chamber should be raised slightly above the general forecourt surface to prevent standing water accumulating on the cover. The cover must offer limited access and should be clearly marked to avoid confusion with other openings.

All wells must be cased with factory drilled or slotted PVC, galvanised, or coated metallic pipe 100mm internal diameter with 0.5mm maximum width openings. The openings must extend from the bottom of the well to within 600mm of the surface.

Blank 100mm diameter well casing should extend to between 300mm and 100mm of the surface. The well casing must be capped at the bottom.

Permeable backfill material with a minimum grain size of 7mm should be used to the top of the perforated area; above this, extending to the access chamber, an impermeable barrier must be provided to prevent the ingress of surface water.

Ducting entry points to all monitoring wells must be sealed to prevent the ingress of water and hydrocarbon vapour *after system testing*.

GROUNDWATER SENSORS

Groundwater monitoring wells should extend to at least 1.5 metres below the mean water table, to a maximum depth of 6 metres. Veeder–Root Groundwater Sensors should be installed only in wet wells where testing has determined that water in the well is not contaminated beyond acceptable limits. A Groundwater Sensor must not be installed in wells where preliminary testing indicates that a hydrocarbon film on the surface of the groundwater water exceeds 0.75mm or where the water table may fall below the bottom of the well.

Figure 23 shows an example installation of a groundwater sensor (Form Nos. 794380-62X).

VAPOUR SENSORS

Veeder–Root Vapour Sensors should be installed only in wells where testing has determined that the soil is not contaminated beyond acceptable limits as determined by local codes.

A Vapour Sensor should **not** be installed in wells at sites which have suffered from either a spill or other source of contamination, or where the sensor may become submerged in groundwater.

NOTE Veeder–Root vapour sensors should not be operated in monitoring wells where the initial vapour sensor resistance exceeds 25 kohms. Where contamination is suspected contact your Veeder–Root Account Administrator at the address on the inside front cover.

Figure 23 shows an example installation of a vapour sensor (Form Nos. 794380-70X).

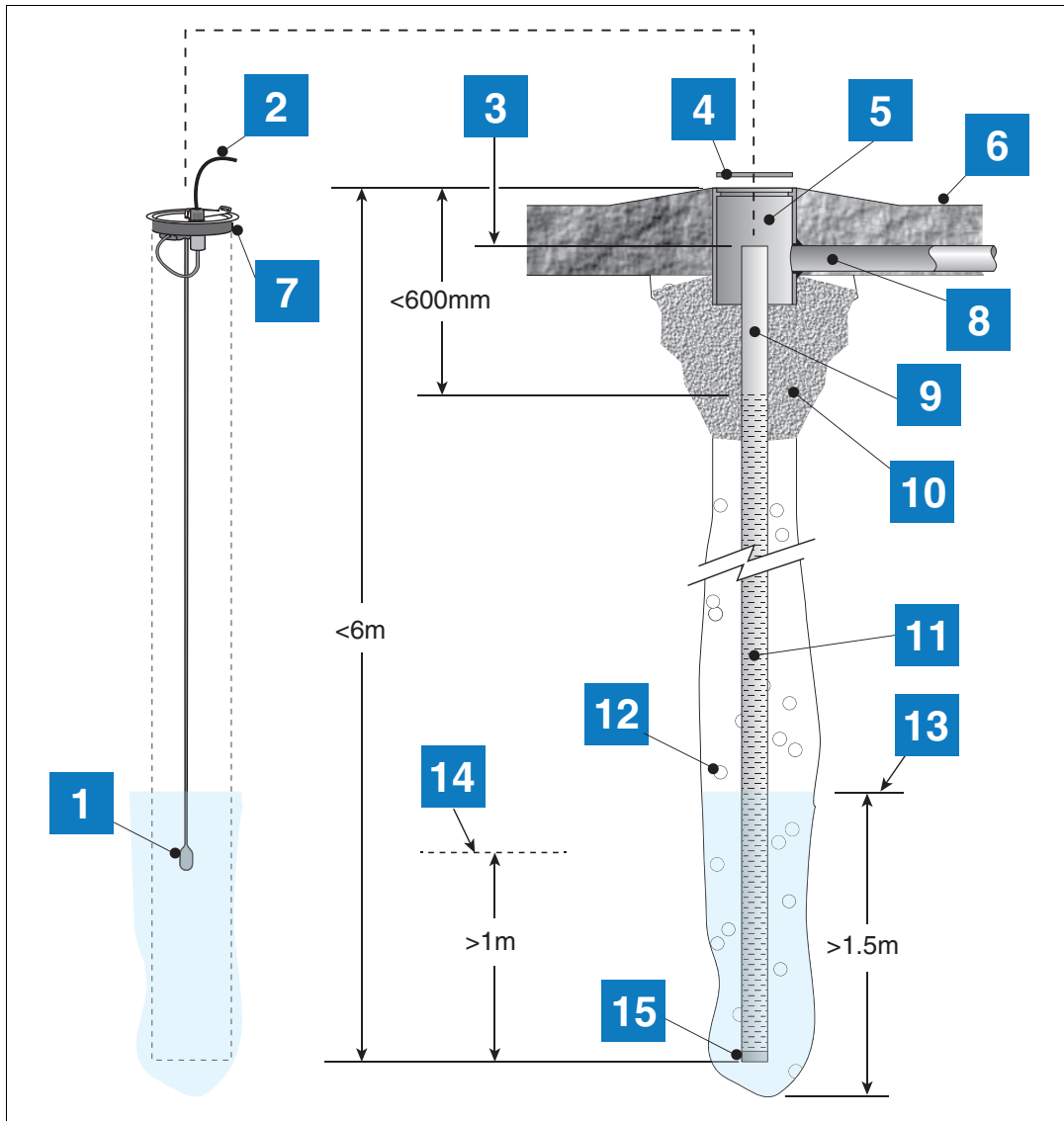

Figure 23. Cross Section Through An Example Groundwater Sensor Installation

LEGEND FOR NUMBERED BOXES IN Figure 23

- | | |
|--|--|
| <ol style="list-style-type: none"> 1. Groundwater sensor (lowered into well casing [Item 11] until sensor is submerged) 2. Cable to TLS console 3. Min. 100mm below cover, max. 100mm above cement 4. Clearly marked, sealed, limited access well cover 5. Raised access chamber 6. Forecourt surface 7. Suspension cap 8. Cable ducting sealed to access chamber 9. 100mm internal chamber blank well casing | <ol style="list-style-type: none"> 10. Waterproof cement (surface water barrier) 11. Factory perforated well casing - max. depth 6m 12. Shingle fill 13. Water Table (1.5m above bottom of well) 14. Level of the lowest tank or product pipework system 15. Well bottom cap |
|--|--|

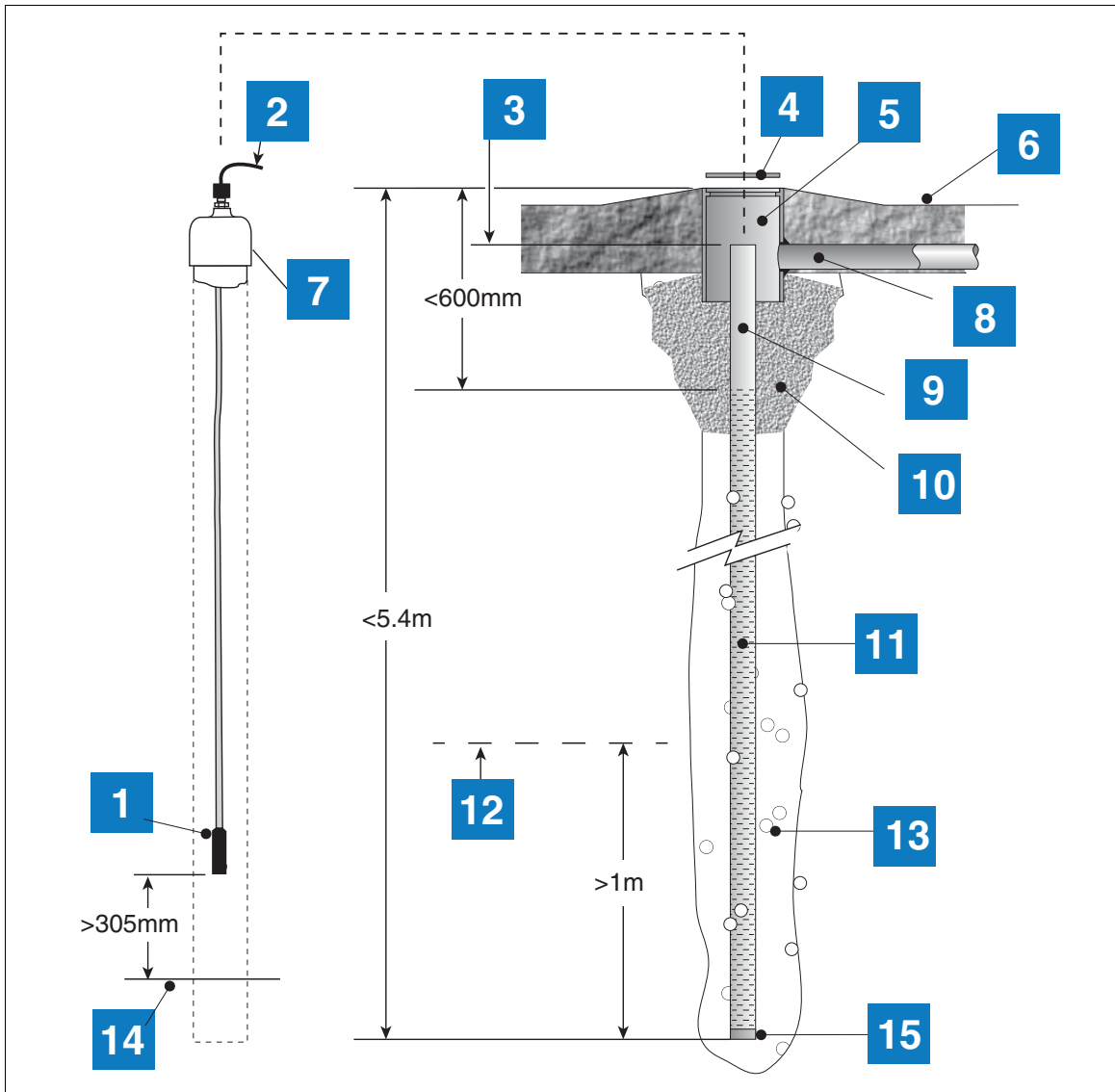

Figure 24. Cross Section Through An Example Vapour Sensor Installation

LEGEND FOR NUMBERED BOXES IN Figure 24

- | | |
|--|---|
| 1. Vapor sensor (lowered into well casing [Item 11] to at least 305mm above any water in well) | 10. Waterproof cement (surface water barrier) |
| 2. Cable to TLS console | 11. Factory perforated well casing - max. depth 5.4m |
| 3. Min. 100mm below cover, max. 100mm above cement | 12. Level of the lowest tank or product pipework system |
| 4. Clearly marked, sealed, limited access well cover | 13. Shingle fill |
| 5. Raised access chamber | 14. Water table or any water in well |
| 6. Forecourt surface | 15. Well bottom cap |
| 7. Suspension cap with cord grip | |
| 8. Cable ducting sealed to access chamber | |
| 9. 100mm internal chamber blank well casing | |

Discriminating Dispenser Pan And Containment Sump Sensors

Figure 25 shows an example installation of a discriminating containment sump sensor (Form Nos. 794380-3XX).

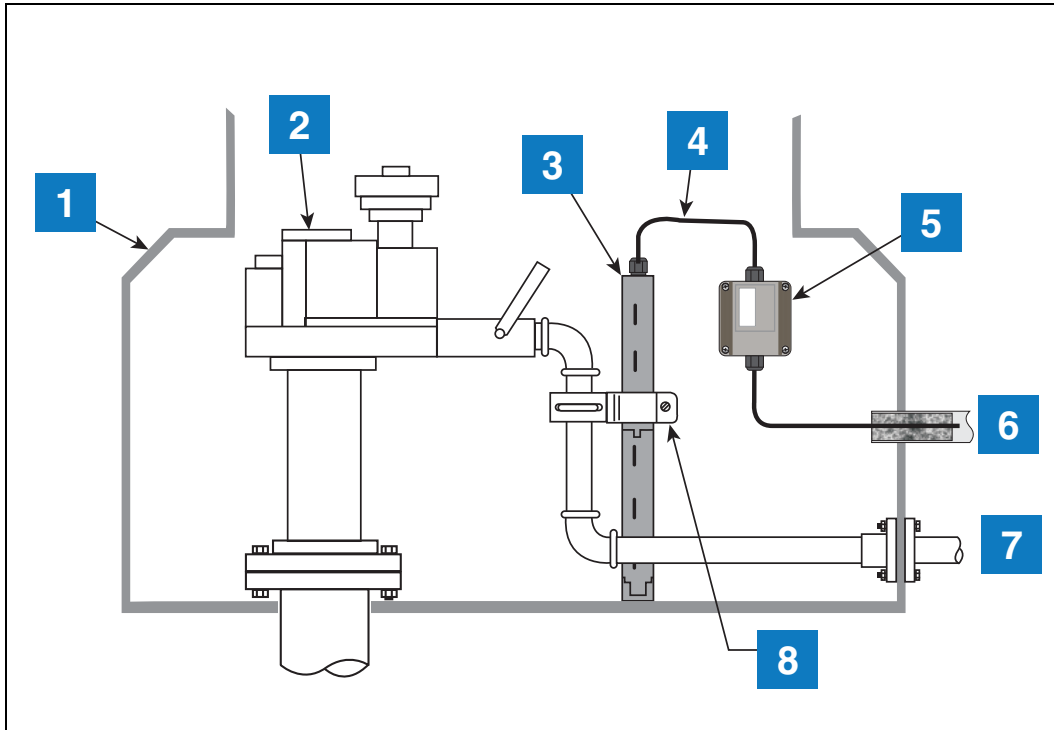

Figure 25. Example Discriminating Containment Sump Sensor Installation

LEGEND FOR NUMBERED BOXES IN Figure 25

- | | |
|--|--|
| <ul style="list-style-type: none"> 1. Containment sump 2. Submersible pump 3. Discriminating sump sensor. IMPORTANT: Do not mount sensor to a flexible product line! 4. Sensor cable with 1/2" NPT cord grip 5. Weatherproof junction box with cord grips | <ul style="list-style-type: none"> 6. Sealed ducting with field cable to TLS console 7. Product line to dispenser 8. Brackets, clamp, etc., from optional Universal Sensor Mounting kit |
|--|--|

Discriminating Interstitial Sensor For Double-Skin fibreglass Tanks

Figure 26 shows an example installation of an Interstitial Sensor (Form No. 7943XX-40X).

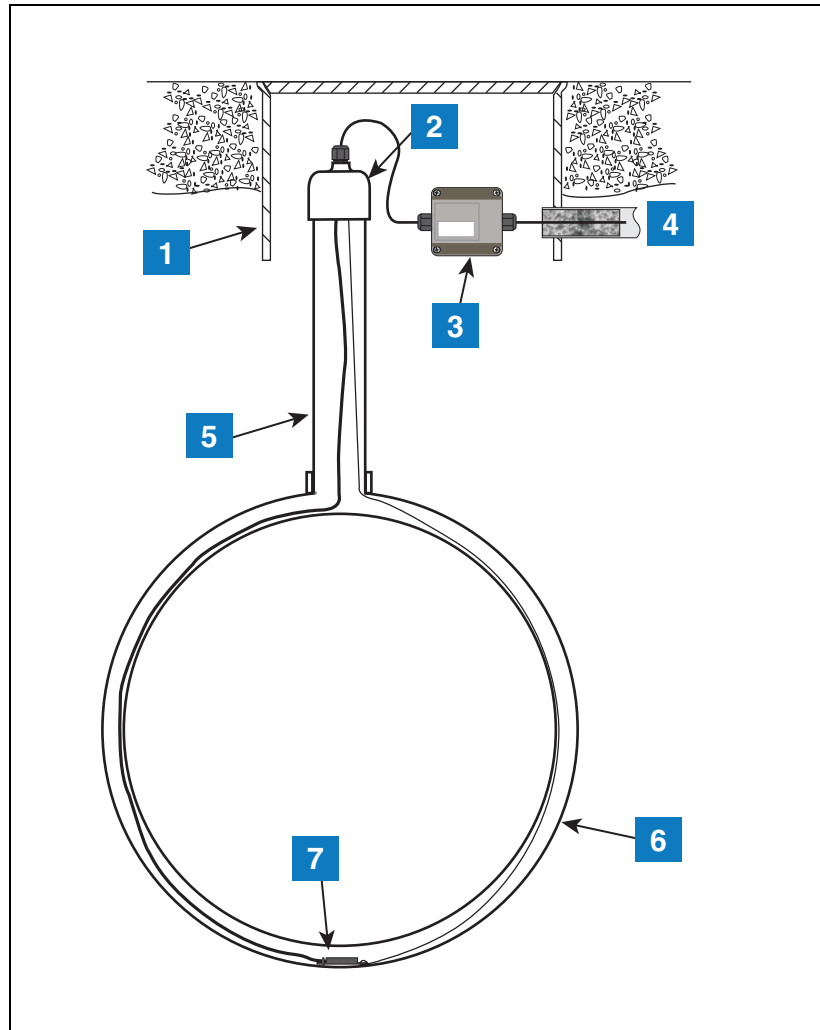

Figure 26. Example Interstitial Sensor Installation - Fibreglass Tank

LEGEND FOR NUMBERED BOXES IN Figure 26

- | | |
|--|---|
| 1. Manhole | 5. Riser pipe |
| 2. Appropriate reducer with 1/2" NPT opening for cable cord grip | 6. Double-skin fibreglass tank |
| 3. Weatherproof junction box with cord grips | 7. Sensor - Must be positioned on the bottom of the tank! |
| 4. Sealed ducting with field cable to TLS console | |

MicroSensor

Figure 27 and Figure 28 show example installations of a MicroSensor (Form No. 794380-344).

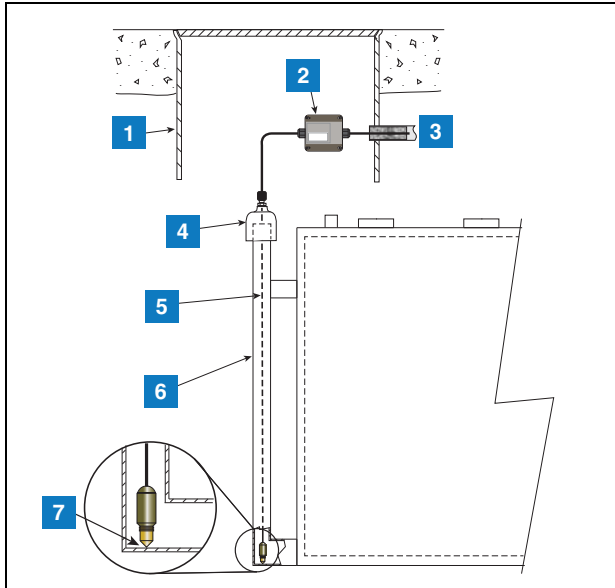

Figure 27. Example Interstitial MicroSensor Install - Steel Tank

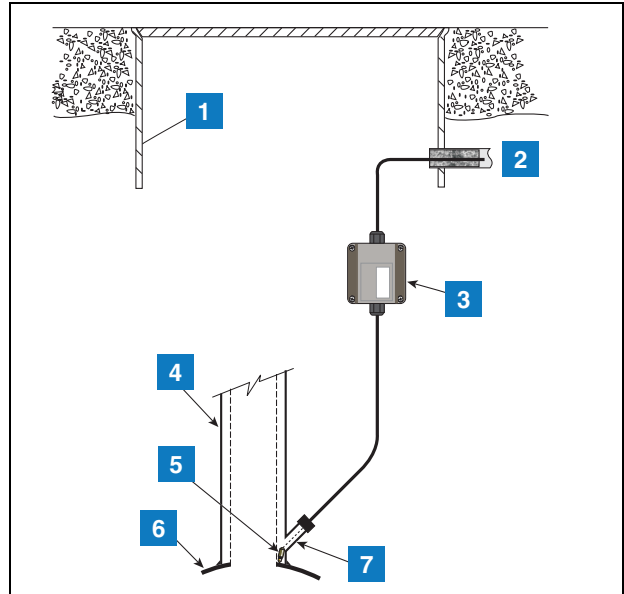

Figure 28. Example MicroSensor Install - Riser Pipe

LEGEND FOR NUMBERED BOXES IN Figure 27

1. Manhole
2. Weatherproof junction box with cord grips
3. Sealed ducting with field cable to TLS console
4. Appropriate reducer with 1/2" NPT opening for cable cord grip
5. Sensor cable
6. Minimum interstitial riser pipe diameter 1 inch (2.54cm)
7. MicroSensor - Must rest on bottom of interstitial riser pipe!

LEGEND FOR NUMBERED BOXES IN Figure 28

1. Manhole
2. Sealed ducting with field cable to TLS console
3. Weatherproof junction box with cord grips
4. Riser pipe
5. MicroSensor
6. Tank
7. Riser containment with minimum 1" (2.54cm) diameter access.

Field Wiring

Field Cable Ducting



Explosion could occur if other wires share ducts with intrinsically safe circuits. Ducting from probes or sensors must not contain any other wiring. Failure to comply with this warning could result in explosion, death, serious personal injury, property loss or equipment damage.

NOTE Improper system operation could result in inaccurate inventory control or undetected potential environmental and health hazards if probe to console wire runs exceed 305 metres.

Minimum diameters for probe and sensor ducting are:

- Up to 20 cables -100mm diameter
- Up to 50 cables -150mm diameter

Run suitable diameter ducting from all probe and sensor locations to the console location. Ducting entry points to all containment sumps and monitoring wells must be sealed to prevent the escape of hydrocarbon vapour and liquid and to prevent the ingress of water.

Ducting plans must be designed to suit local site requirements and must conform to all local, national, EC and industry standards and regulations.

NOTE For multiple tank gauge installations, probe and sensor wiring from different tank gauges must be contained in separate ducts. Improper system operation will result if sensor and probe wiring from more than one gauge is contained in a common duct.

Unless specified otherwise, draw pits should be sited at 10 metre intervals or where acute ducting angles are unavoidable.

Ensure that all ducting is equipped with cable pull through ropes and that all visible ducting is properly fixed and finished off in a neat and tidy state.

Equipment Connected To The RS-232 Port

(Level 1 Installation Only)

Any equipment such as a pump controller or point-of-sale terminal connected to the RS-232 port must meet the following criteria:

- The equipment must have an EIA standard RS-232C or RS-232D communications protocol.
- The equipment must *NOT* be installed over or in a hazardous location

The RS-232 Interface can be used for direct local attachment of terminals if the cable run is no more than 15 metres. Veeder-Root does not guarantee proper equipment operation if RS-232 cable runs exceed 15 metres.

NOTE RS-232 cable runs longer than 15 metres could result in data errors.

Run cable from the peripheral equipment location to the system console location. At least 1 metre of free cable must be left for subsequent connection at both ends.

External Inputs (TLS-350, TLS-450, TLS-450PLUS, TLS-XB Or TLS-300)

TLS consoles can accept inputs (either normally closed or normally open) from an external non-intrinsically safe switch.



Intrinsically safe equipment must not be connected to TLS console external input modules. Failure to comply with this warning could result in explosion, death, serious personal injury, property loss or equipment damage.

Wiring from external devices to the system console input connector must be two-core, 2mm² shielded cable. Run cable from the external device to the system console location. At least 2 metres of free cable must be left for subsequent connection.

Output Relays

Output Relay Contact, resistive load, 240 Vac, 2 A max. (or 24 Vdc, 2 A max.). For TLS4/8601, TLS-450/8600 and TLS-450PLUS/8600 consoles: Output Relay Contact, resistive load, 120/240 Vac, 5 A max. (or 30 Vdc, 5 A max.).



Do not connect output relays to systems or devices that draw more than the stated amperes.

NOTE Alarm relays remain activated for the duration of the alarm condition. They may be used to shutdown pumps during leak, low level or high water conditions. Alarm relays cannot actuate flow control devices.

Wiring from external alarms to the TLS console relay output connector to be standard colour coded three core 2mm² cable.

Run cable from the external alarm to the system console location. At least 1 metre of free cable must be left for subsequent connection.

NOTE External alarms cannot be powered from a TLS console. A separate fused power supply must be provided.

TLS High Level Alarm

The TLS High Level Alarm can be supplied to the site before installation of the TLS system components if required. Contact your Veeder-Root representative if you have special delivery requirement.

The TLS High Level Alarm is 240 Vac powered and requires a dedicated supply via a switched 5 A fused neon indication spur within 1 metre of the system console. (See Figure 3 on page 9.)

The TLS High Level Alarm must be located outside any hazardous area as defined by IEC/EN 60079-10 Classification of Hazardous Areas. The chosen location and the attendant cable specification must comply with all EC, national and local regulations.

NOTE Customers and contractors are strongly advised to check with the local licensing authority before finalizing the alarm location and cabling.

Cable Specifications



The following cable types are considered a part of an approved installation. Substitution of cable may impair intrinsic safety and may invalidate system approval. See accompanying descriptive system documents and/or Appendix A for cable restrictions.

All specifications are in free air at +30°C:

Table 3. Probe Cable Specification (GVR P/N 222-001-0029) - Maximum Of 305 Metres Per Probe

Number of Cores	2
Conductors	Bare copper, 24/0.20mm, diameter 1.1mm
Insulation	PVC R2 to CEI 20-11, colour black 1/black 2, radial thickness 0.54mm, twisting 1x 2, lay pitch 76mm
Shielding	Aluminium polyester tape, tinned copper drain wire 7/0.30mm
Sheath	PVC RZ FR hydrocarbon resistant, colour blue, radial thickness 0.80mm
Diameter	6.10mm
Conductor Resistance	25 ohm/km
Drain Wire Resistance	15 ohm/km
Capacitance	0.14 μ F/km (140 pF/m)
Inductance	0.65 mH/km (0.65 μ H/m)
LR Ratio	17 μ H/ohm
Insulation Resistance	1050 Mohm/km
Voltage Core to Core	500
Voltage Core to Screen	500
Voltage Earth to Screen	500
Voltage Test	1kV/1 minute
Standard	IEC 60227: Polyvinyl chloride insulated cable

Table 4. Sensor Cable Specification (GVR P/N 222-001-0030) - Maximum Of 305 Metres Per Sensor

Number of Cores	3
Conductors	Bare copper, 24/0.20mm, diameter 1.1mm
Insulation	PVC R2 to CEI 20-11, colour black 1/black 2/black 3, radial thickness 0.54mm, twisting 1x 32, lay pitch 76mm
Shielding	Aluminium polyester tape, tinned copper drain wire 7/0.30mm
Sheath	PVC RZ FR hydrocarbon resistant, colour blue, radial thickness 0.80mm
Diameter	6.380mm
Conductor Resistance	25 ohm/km
Drain Wire Resistance	15 ohm/km
Capacitance	0.13 μ F/km (130 pF/m)
Inductance	0.65 mH/km (0.65 μ H/m)
LR Ratio	17 μ H/ohm
Insulation Resistance	1400 Mohm/km
Voltage Core to Core	500

Table 4. Sensor Cable Specification (GVR P/N 222-001-0030) - Maximum Of 305 Metres Per Sensor

Voltage Core to Screen	500
Voltage Earth to Screen	500
Voltage Test	1kV/1 minute
Standard	IEC 60227: Polyvinyl chloride insulated cable

Table 5. Data Transmission Cable Specification (GVR P/N 4034-0147)

Cable Type	2 x twisted pair, PVC insulated, foil wrapped, common drain
Conductor Stranding	7/0.25mm
Characteristic Impedance	58 ohms
Capacitance	203 pF per metre
Attenuation	5.6 dB per 100 m
Operating Temp. Range	-30°C to +70°C
Insulation	PVC
Sheath	Polyethylene
Sheath Colour	Grey
Core Colours	Black, red, green, white
Nominal Outside Diameter	4.2 mm

Table 6. Screened Multicore Cable - TLS Terminal Box To Console

Cable Type	Screened Multicore
Number of cores	18
Conductor Stranding	16/0.2mm
Current Carrying Capacity	2.5 A per core
Resistance	40 ohms/km
Max. Working Voltage	440 V r.m.s.
Screen	copper braided
Core/Screen Capacitance	200 pF/m (nominal)
Insulation	0.45mm PVC
Sheath	PVC
Sheath Colour	Grey
Core Colours	Red, blue, green, yellow, white, black, brown, violet, orange, pink, turquoise, grey, red/blue, green/red, yellow/red, white/red, red/black, red/brown

Table 6. Screened Multicore Cable - TLS Terminal Box To Console

Cable Type	Screened Multicore
Nominal Outside Diameter	12.0mm

Field Wiring

PROBE TO TLS CONSOLE

Pull appropriate cable from the each probe/sensor location to the TLS console.



Explosion could occur if other, non-intrinsically safe wires share TLS intrinsically safe wire conduits or wiring troughs. Conduits and wiring troughs from probes and sensors to the console must not contain any other wires.

NOTE At least 2 metres of free cable must be left for connection at both the TLS console and the probe locations.

Ensure that **all** cables are correctly identified. All probe field wiring **must** be legibly and permanently labelled with the tank number.

NOTE Failure to correctly mark probe field wiring may lead to re-work, delays in system installation and additional charges.

MAXIMUM CABLE LENGTHS

A maximum of 305 metres of cable length per sensor or probe must be observed. Details for total allowance per system are given in Appendix A.

DUCTING ENTRY TO SYSTEM CONSOLE LOCATION

Connection to the TLS console may only be made by a Veeder–Root authorised engineer.

The cable route from the ducting entry to the system console must be clearly defined and all necessary preliminary work undertaken. All necessary holes must be drilled through walls, counters, etc.; cable trays fitted, ducting with draw cords installed and adequate access for the installation of the cable provided.

RELAY OUTPUT WIRING

TLS console relays may be connected to external systems or devices provided that they do not draw more than 2 amperes (5A for TLS4/8601, TLS-450/8600 and TLS-450PLUS/8600 consoles).

NOTE Connection to the TLS console may only be made by a Veeder–Root authorised engineer.

Connection to pump contactors should be made using a multicore cable rated for 240 Vac at a maximum of 2 amperes and suitable for the intended cable route. At least 1 metre of free cable must be left for subsequent connection to the system console.

NOTE Alarm relays remain activated for the duration of the alarm condition. They may be used to shutdown pumps during leak, low level or high water conditions. Alarm Relays cannot actuate flow control devices.

Appendix A - Assessment Documents

This appendix includes assessment documents for intrinsically safe systems installed in Group IIA locations, type protection “i”.

Certification Description

SPECIAL CONDITIONS FOR SAFE USE

The devices must be installed as part of the intrinsic safety system as defined in the descriptive system documents, included with this certificate.

A risk analysis must be performed to determine if the installation location is susceptible to lightning or other electric surges. If necessary, protection against lightning and other electrical surges must be provided in accordance with IEC/EN 60079-25.

Intrinsically Safe TLS Tank Gauge System

EC-Type Examination Type Certificate: **DEMKO 06 ATEX 137480X**

IECEX Certificate of Conformity: **IECEX ULD 08.0002X**

An Intrinsically System is comprised of a combination of Associated Apparatus and Intrinsically Safe Apparatus described in their respective Type Examination Certificates.

Installation requirements for TLS Systems appear in the Descriptive System Documents listed below:

<u>Associated Apparatus</u>	<u>ATEX Document No.</u>	<u>IECEX Document No.</u>
TLS-350R or TLS-350 Plus	331940-001	331940-101
TLS-300	331940-002	331940-102
TLS-50 or TLS2 or TLS-IB	331940-003	331940-103
Tank Gauge Accessories	331940-005	331940-105
TLS-450/8600, TLS-450PLUS/8600	331940-006	331940-106
TLS4/8601	331940-017	331940-117
TLS-XB/8603	331940-020	331940-120

Associated Apparatus - Non-Hazardous Area

CONDITIONS FOR SAFE USE THAT APPLY TO ASSOCIATED APPARATUS

Cable and wiring used to connect the Associated Apparatus to the Intrinsically Safe Devices, shall have a maximum L/R ratio of 200 $\mu\text{H}/\text{ohm}$.

The acceptable operating temperature range for the Associated Apparatus is: $0^{\circ}\text{C} \leq T_a \leq 40^{\circ}\text{C}$ except for the TLS4/8601 and the TLS-XB/8603 which have an operating range of: $0^{\circ}\text{C} \leq T_a \leq 50^{\circ}\text{C}$.

The maximum source voltage for the associated apparatus is: $U_m = 250\text{V}$.

These Apparatus comply with the electrical dielectric strength test as stated in Clause 6.4.12 of EN 60079-11, Electrical Apparatus for Explosive Gas Atmospheres.

The values for C_o and L_o are the aggregate sum of all terminals when these devices are used in installations that do not follow the System Descriptive Documents specified in 06 ATEX 137480X. Based on compliance with EN 60079-25 the values for C_o and L_o do not apply when these devices are installed in accordance with the System Descriptive Documents specified in 06 ATEX 137480X.

This device must be installed as part of the intrinsic safety system defined in DEMKO 06 ATEX 137480X. The descriptive system documents included with the aforementioned certificate must be followed during installation.

The maximum cable length between an associated apparatus and an intrinsically safe sensor is 305 metres. The maximum cable length between associated apparatus, e.g., a TLS RF console and any other ATG, is 25 metres.

The TLS RF Console contains an optically isolated, intrinsically safe circuit. All connection facilities are considered in parallel, the C_i and L_i values represent the aggregate sum of the internal capacitance and inductance within the intrinsically safe circuit.

To ensure safe operation, all covers must be secured in place in both the intrinsically safe and unspecified circuit field wiring compartments on the TLS-XB, TLS-450/8600, TLS-450PLUS/8600, TLS-350, TLS-350R, TLS-300, TLS-50, TLS4/8601, TLS2, TLS-IB, and TLS RF consoles.

All Modules and/or module covers must be secured in place in both the intrinsically safe and unspecified circuit field wiring compartments to ensure safe operation of the TLS-XB, TLS-450/8600, TLS-450PLUS/8600, TLS-350 and TLS-350R consoles.

The Electrical Data for Associated Apparatus are shown in the following tables.

Cable and wiring used to connect the Associated Apparatus to the Intrinsically Safe Devices, shall have a maximum L/R ratio of 200 uH/ohm.

The acceptable operating temperature range for the Associated Apparatus is:
 For the TLS4/8601 and the TLS-XB -- 0°C ≤ Ta ≤ 50°C
 For all other Associated Apparatus -- 0°C ≤ Ta ≤ 40°C

Electrical Data Table for Associated Apparatus

Console Description	EC Type Examination Certificate Numbers	Data Per TLS Console			Total Per TLS System		
		Uo volts	Io amps	Po watts	Lo mH	Co µF	Maximum Cable Capacitance and Length
TLS-450, TLS-450PLUS/8600 with Tw o-Wire I.S. Devices	DEMKO 07 ATEX 16184X IECEX UL 07.0012X	12.6	0.177	0.563	4.50	13.4	5.0 µF 15,240 Metres (applied to all combinations of I.S. Devices)
TLS-450, TLS-450PLUS/8600 with Three-Wire I.S. Devices		14.1	0.196	0.63	2.90	8.24	

Console Description	EC Type Examination Certificate Numbers	Data Per TLS Console			Total Per TLS System		
		Uo volts	Io amps	Po watts	Lo mH	Co µF	Maximum Cable Capacitance and Length
TLS4/8601 with Tw o-Wire I.S. Devices	DEMKO 11 ATEX 1111659X IECEX UL 11.0049X	12.6	0.177	0.563	4.50	13.4	5.0 µF 15,240 Metres (applied to all combinations of I.S. Devices)
TLS4/8601 with Three-Wire I.S. Devices		14.1	0.196	0.63	2.90	8.24	

Console Description	EC Type Examination Certificate Numbers	Data Per TLS Console			Total Per TLS System		
		Uo volts	Io amps	Po watts	Lo mH	Co µF	Maximum Cable Capacitance and Length
TLS-XB/8603 with Tw o-Wire I.S. Devices	DEMKO 12 ATEX 1204670X IECEX UL 12.0022X	12.6	0.177	0.563	4.50	13.4	5.0 µF 15,240 Metres (applied to all combinations of I.S. Devices)
TLS-XB/8603 with Three-Wire I.S. Devices		14.1	0.196	0.63	2.90	8.24	

Cable and wiring used to connect the Associated Apparatus to the Intrinsically Safe Devices, shall have a maximum L/R ratio of 200 uH/ohm. The acceptable operating temperature range for the Associated Apparatus is: $0^{\circ}\text{C} \leq T_a \leq 40^{\circ}\text{C}$.

Electrical Data Table for Associated Apparatus

Console Description	EC Type Examination Certificate Numbers	Data Per TLS Console			Total Per TLS System		
		Uo volts	Io amps	Po watts	Lo* mH	Co μF	Maximum Cable Capacitance and Length
TLS-350 Plus 8470 TLS-350R 8482	DEMKO 06 ATEX 137481X IECEX UL 08.0015X	12.6	0.196	0.62	3.70	13.5	5.0 μF 15240 Metres
TLS-300 8485	DEMKO 06 ATEX 137484X IECEX UL 11.0002X	12.6	0.194	0.62	3.70	13.5	3.2 μF 9753 Metres
TLS-50 8469 TLS2 8560 TLS-IB 8466	DEMKO 06 ATEX 137485X IECEX UL 09.0032X	12.6	0.189	0.60	3.70	13.5	0.8 μF 2438 Metres

*The entity parameters are for informational purposes only. Refer to the applicable system descriptive document for allowable connections.

Intrinsically-Safe Apparatus

CONDITIONS FOR SAFE USE THAT APPLY TO INTRINSICALLY-SAFE APPARATUS

Before installing or taking into a hazardous area, earth the unit in a SAFE AREA to remove any static charge. Then immediately transport the unit to the installation site; do not rub or clean the unit prior to installation. Cleaning is not required under normal service conditions; do not rub or clean the device after installation. If the unit is not fixed to a known earth point when installed, ensure that a separate earth connection is made to prevent the potential of static discharge. When fitting or removing the unit, use of anti-static footwear and clothing is required.

The acceptable operating temperature range for the Intrinsically Safe Devices is: $-40^{\circ}\text{C} \leq T_a \leq 60^{\circ}\text{C}$. The temperature classification for the Intrinsically-Safe Devices is T4.

These Intrinsically-Safe Devices comply with the electrical dielectric strength test as stated in Clause 6.4.12 of EN 60079-11, Electrical Apparatus for Explosive Gas Atmospheres.

This device must be installed as part of the intrinsic safety system defined in DEMKO 06 ATEX 137480X. The descriptive system documents included with the aforementioned certificate must be followed during installation.

The descriptive system documents include references to simple apparatus. Simple apparatus used with these systems must not contain any inductance or capacitance and must also comply with all requirements indicated in the system descriptive document.

Each apparatus within the system may have individual conditions of safe use. Each apparatus certificate must be reviewed to determine the suitability of each apparatus.

In addition to certified intrinsically safe apparatus, Veeder-Root also provides simple apparatus that comply with the requirements of IEC/EN 60079-11, Clause 5.7, which include TLS sensors 7943/7946. Figures showing these devices are installation examples and do contain components that are outside the scope of this ATEX System Certification.

The Electrical Data for Intrinsically-Safe Devices are shown in the following two tables.

The acceptable operating temperature range for the Intrinsically Safe Devices are listed below.
The temperature classification for the Intrinsically Safe Devices T4.

Input Electrical Data Table for Intrinsically Safe Devices

Product Description	EC Type Examination Certificate Numbers	Operating Temperature Range	U _i volts	I _i amps	P _i watts	L _i mH	C _i μF	Additional Conditions
Mag Plus Probe 8462, 8463, 8563	DEMKO 06 ATEX 0508841X IECEX UL 06.0001X	-40°C ≤ Ta ≤ 60°C	12.6	0.196	0.62	4.00	1.221	1, 3, 6, 7, 8
Mag Sump Sensor 8570	DEMKO 06 ATEX 0508841X IECEX UL 06.0001X	-40°C ≤ Ta ≤ 60°C	12.6	0.196	0.62	4.00	1.221	1, 2, 3, 6, 7
PLLD Line Leak 8484	DEMKO 06 ATEX 137486X IECEX UL 08.0014X	-40°C ≤ Ta ≤ 60°C	12.6	0.196	0.62	0	2.24	2, 3
DPLLD Line Leak 332681	DEMKO 07 ATEX 141031X IECEX UL 07.0011X	-40°C ≤ Ta ≤ 60°C	12.6	0.196	0.62	0.4	0.0264	2, 3
TLS Sensors 7943/7946	Simple Apparatus - Not Evaluated by an ExNB	-40°C ≤ Ta ≤ 60°C	N/A	N/A	N/A	0	0	1
TLS RF Console 8580	DEMKO 06 ATEX 137478X IECEX UL 06.0003X	-40°C ≤ Ta ≤ 60°C	12.6	0.196	0.62	3.70	0.962	N/A
TLS Radio Transmitter Inputs 332235	DEMKO 06 ATEX 137478X IECEX UL 06.0003X	-40°C ≤ Ta ≤ 60°C	3.90	1.29	1.20	0.283	12076	N/A
Vacuum-Sensor 332175-xxx	DEMKO 07 ATEX 29144X IECEX UL 09.0033X	-40°C ≤ Ta ≤ 60°C	12.6	0.196	0.62	0.4	0.0264	2, 3
Vapor Flow Meter 331847	IECEX UL 10.0027X	-40°C ≤ Ta ≤ 60°C	12.6	0.196	0.62	0.363	0.0264	2, 3
Vapor Pressure Sensor 333255	IECEX UL 10.0043X	-40°C ≤ Ta ≤ 60°C	12.6	0.196	0.62	0.363	0.0264	2
Mag Plus1 Probe	TUV 12 ATEX 105828 IECEX TUN 12.0027	-20°C ≤ Ta ≤ 60°C	13	0.200	0.62	0.41	20 nF	1, 6, 7, 8
Surge Protector 800 A, 8/20 μS 848100-00X	DEMKO 13 ATEX 1306057X IECEX UL 13.0074X	-40°C ≤ Ta ≤ 60°C	12.6	0.196	0.62	0	0	9, 10

Explanation of Additional Conditions:

- Before installing or taking into a hazardous area, earth the unit in a SAFE AREA to remove any static charge. Then immediately transport the unit to the installation site; do not rub or clean the unit prior to installation. Cleaning is not required under normal service conditions; do not rub or clean the device after installation. If the unit is not fixed to a known earth point when installed, ensure that a separate earth connection is made to prevent the potential of static discharge. When fitting or removing the unit, use of anti-static footwear and clothing is required.
- This device is not intended to be installed across a boundary wall.
- Enclosure contains aluminum. Care must be taken to avoid ignition hazards due to impact or friction
- Non serviceable, fixed device. Must be carried in and out of hazardous location as an assembly.
- Maximum cable length between the radio transmitter and battery pack shall not exceed 7.62 m (25 feet).
- A risk analysis must be performed to determine if the installation location is susceptible to lightning or other surges. If necessary, add protection against lightning and other electrical surges in accordance with IEC/EN 60079-25, section 10.
- Connect the barrier ground to a single point earth ground at the power distribution panel with a 4 sq. mm (10 AWG) (or larger) conductor. Grounding must comply with IEC/EN 60079-14, Clause 6.3.
- The devices have been evaluated in conjunction with the intrinsic safety system defined in DEMKO 06 ATEX 137480X. The descriptive system documents and manuals included with the aforementioned certificate must be followed during installation and the appropriate Veeder Root accessories must be used. Manual 577014-031 details applicable process connections in accordance with IEC/EN 60079-26.
- This device does not comply with the dielectric requirements of IEC/EN60079-11 between the circuit and earthing conductor. Transient over-voltage protection of 75V is provided between the circuit and earthing conductor. Expert guidance is needed to determine suitability for a specific installation in accordance with IEC/EN60079-14:2010 clause 12.3.
- The devices have been evaluated in conjunction with the intrinsic safety system defined in IECEX ULD 08.0002X. The descriptive system documents and manuals included with the aforementioned certificate must be followed during installation and the appropriate Veeder-Root accessories must be used.

Output Electrical Data Table for Intrinsically Safe Devices

Product Description	EC Type Examination Certificate Numbers	Operating Temperature Range	U _o volts	I _o amps	P _o watts	L _o mH	C _o μF	Additional Conditions
TLS Radio Transmitter Outputs 332235	DEMKO 06 ATEX 137478X IECEX UL 06.0003X	-40°C ≤ Ta ≤ 60°C	10.30	0.193	0.5	3.70	13.5	1, 4, 5
Battery Pack Outputs 332425	DEMKO 06 ATEX 137478X IECEX UL 06.0003X	-40°C ≤ Ta ≤ 60°C	3.90	1.29	1.20	0.283	12076	1, 4, 5
Surge Protector 848100-00X	DEMKO 13 ATEX 1306057X IECEX UL 13.0074X	-40°C ≤ Ta ≤ 60°C	12.6	0.196	0.62	4.00	1.221	N/A

Appendix B - TLS Product Labels

TLS-450 INVENTORY MEASUREMENT SYSTEM

Manufactured By:
Veeder-Root Co.
Duncansville, PA 16635 U.S.A.

ASSOCIATED APPARATUS FOR NON HAZARDOUS LOCATIONS
INSTALLED IN ACCORDANCE WITH DESCRIPTIVE SYSTEM
DOCUMENT 331940-006 AND MANUAL NO. 577013-578.

0°C ≤ Ta ≤ +40°C

Um = 250 Volts
APPAREILLAGE CONNEXE

INPUT POWER RATINGS:
120/240 VAC, 50/60 Hz,
2.0 A Max

FORM NO.:
SERIAL NO.:

CE 1180 Ex II (1) G
[Ex ia] IIA
DEMKO 07 ATEX 16184X
DEMKO 06 ATEX 137480X

TLS-450 LABEL

TLS-450 INVENTORY MEASUREMENT SYSTEM

Manufactured By:
Veeder-Root Co.
Duncansville, PA. 16635 U.S.A.

ASSOCIATED APPARATUS FOR NON HAZARDOUS LOCATIONS
INSTALLED IN ACCORDANCE WITH DESCRIPTIVE SYSTEM
DOCUMENT 331940-106 AND MANUAL NO. 577013-578.

ASSOCIATED APPARATUS

0°C ≤ Ta ≤ +40°C

Um = 250 Volts

[Ex ia Ga] IIA

INPUT POWER RATINGS:
120/240 VAC, 50/60 Hz,
2.0 A Max

FORM NO.:
SERIAL NO.:

IECEX UL 07.0012X
IECEX ULD 08.0002X

TLS-450 LABEL

TLS-350/TLS-350R INVENTORY MEASUREMENT SYSTEM

Manufactured By:
Veeder-Root Co.
Duncansville, PA 16635 U.S.A.

ASSOCIATED APPARATUS FOR NON HAZARDOUS LOCATIONS
INSTALLED IN ACCORDANCE WITH DESCRIPTIVE SYSTEM
DOCUMENT 331940-001 AND MANUAL NO. 577013-578.

0°C ≤ Ta ≤ +40°C

INPUT POWER RATINGS:
240 VAC, 50/60 Hz,
2.0 A Max

FORM NO.: *****-***
SERIAL NO.: *****

CE 1180 Ex II (1) G
[Ex ia] IIA
DEMKO 06 ATEX 137481X
DEMKO 06 ATEX 137480X

TLS-350 LABEL

TLS-350/TLS-350R INVENTORY MEASUREMENT SYSTEM

Manufactured By:
Veeder-Root Co.
Duncansville, PA 16635 U.S.A.

ASSOCIATED APPARATUS FOR NON HAZARDOUS LOCATIONS
INSTALLED IN ACCORDANCE WITH DESCRIPTIVE SYSTEM
DOCUMENT 331940-101 AND MANUAL NO. 577013-578.

0°C ≤ Ta ≤ +40°C

INPUT POWER RATINGS:
240 VAC, 50/60 Hz,
2.0 Amp Max

FORM NO.: *****-***
SERIAL NO.: *****

[Ex ia Ga] IIA
IECEX UL 08.0015X
IECEX ULD 08.0002X

TLS-350 LABEL

TLS2 INVENTORY MEASUREMENT SYSTEM

Manufactured By:
Veeder-Root Co.
Duncansville, PA 16635 U.S.A.

ASSOCIATED APPARATUS FOR NON HAZARDOUS LOCATIONS
INSTALLED IN ACCORDANCE WITH DESCRIPTIVE SYSTEM
DOCUMENT 331940-003 AND MANUAL NO. 577013-578.

0°C ≤ Ta ≤ +40°C

INPUT POWER RATINGS:
120/240 VAC, 50/60 Hz,
2.0 A Max

FORM NO.: *****-***
SERIAL NO.: *****

CE 1180 Ex II (1) G
[Ex ia] IIA
DEMKO 06 ATEX 137485X
DEMKO 06 ATEX 137480X

TLS2 LABEL

TLS2 INVENTORY MEASUREMENT SYSTEM

Manufactured By:
Veeder-Root Co.
Duncansville, PA 16635 U.S.A.

ASSOCIATED APPARATUS FOR NON HAZARDOUS LOCATIONS
INSTALLED IN ACCORDANCE WITH DESCRIPTIVE SYSTEM
DOCUMENT 331940-103 AND MANUAL NO. 577013-578.

0°C ≤ Ta ≤ +40°C

INPUT POWER RATINGS:
120/240 VAC, 50/60 Hz,
2.0 A Max

FORM NO.: *****-***
SERIAL NO.: *****

[Ex ia Ga] IIA
IECEX UL 09.0032X
IECEX ULD 08.0002X

TLS2 LABEL

TLS-300 INVENTORY MEASUREMENT SYSTEM

Manufactured By:
Veeder-Root Co.
Duncansville, PA 16635 U.S.A.

ASSOCIATED APPARATUS FOR NON HAZARDOUS LOCATIONS
INSTALLED IN ACCORDANCE WITH DESCRIPTIVE SYSTEM
DOCUMENT 331940-002 AND MANUAL NO. 577013-578.

0°C ≤ Ta ≤ +40°C

INPUT POWER RATINGS:
240 VAC, 50/60 Hz,
2.0 A Max

FORM NO.: *****-***
SERIAL NO.: *****

CE 1180 Ex II (1) G
[Ex ia] IIA
DEMKO 06 ATEX 137484X
DEMKO 06 ATEX 137480X

TLS-300 LABEL

8601 INVENTORY MEASUREMENT SYSTEM

Manufactured by:
Veeder-Root Co.
Duncansville, PA 16635 U.S.A.

Associated apparatus, for non-hazardous locations,
Installed according to Descriptive System Document
331940-017 and manual 577013-578.

Um = 250 Volts
Input Power Ratings:
120/240 Vac, 50/60 Hz
2.0 A Max
Form No.:
Serial No.:

0°C ≤ Ta ≤ +50°C

CE 1180 Ex II (1) G

[Ex ia] IIA
DEMKO 11 ATEX 1111659X
DEMKO 06 ATEX 137480X

TLS4/8601 LABEL
(AC INPUTS)

8601 INVENTORY MEASUREMENT SYSTEM

Manufactured by:
Veeder-Root Co.
Duncansville, PA 16635 U.S.A.

INSTALLED IN ACCORDANCE WITH DESCRIPTIVE
SYSTEM DOCUMENT 331940-117 AND MANUAL
577013-578.

Um = 250 Volts
Input Power Ratings:
120/240 Vac, 50/60 Hz
2.0 A Max
Form No.:
Serial No.:

0°C ≤ Ta ≤ +50°C

ASSOCIATED APPARATUS

[Ex ia Ga] IIA
IECEx UL 11.0049X
IECEx ULD 08.0002X

BAR CODE AREA

TLS4/8601 LABEL
(AC INPUTS)

8601 INVENTORY MEASUREMENT SYSTEM

Manufactured by:
Veeder-Root Co.
Duncansville, PA 16635 U.S.A.

Associated apparatus, for non-hazardous locations,
Installed according to Descriptive System Document
331940-017 and manual 577013-578.

Um = 250 Volts
Input Power Ratings:
5 Vdc, 4.0 A
24 Vdc, 2.0 A
Form No.:
Serial No.:

0°C ≤ Ta ≤ +50°C

CE 1180 Ex II (1) G

[Ex ia] IIA
DEMKO 11 ATEX 1111659X
DEMKO 06 ATEX 137480X

TLS4/8601 LABEL
(DC INPUTS)

8601 INVENTORY MEASUREMENT SYSTEM

Manufactured by:
Veeder-Root Co.
Duncansville, PA 16635 U.S.A.

INSTALLED IN ACCORDANCE WITH DESCRIPTIVE
SYSTEM DOCUMENT 331940-117 AND MANUAL
577013-578.

Um = 250 Volts
Input Power Ratings:
5 Vdc, 4.0 A
24 Vdc, 2.0 A
Form No.:
Serial No.:

0°C ≤ Ta ≤ +50°C

ASSOCIATED APPARATUS

[Ex ia Ga] IIA
IECEx UL 11.0049X
IECEx ULD 08.0002X

BAR CODE AREA

TLS4/8601 LABEL
(DC INPUTS)

TLS-RF INVENTORY MEASUREMENT SYSTEM

Manufactured by: Veeder-Root Co.
Duncansville, PA 16635 U.S.A.

Associated Apparatus For Non-hazardous Locations,
Installed According To Descriptive System Document
331940-005 And Manual No. 577013-578.

0°C ≤ Ta ≤ +40°C

APPAREILLAGE CONNEXE
INPUT POWER RATINGS:
120/240 VAC, 50/60 Hz,
2.0 A Max
FORM NO.: *****
SERIAL NO.: *****

[Ex ia] IIA
DEMKO 06 ATEX 137478X
DEMKO 06 ATEX 137480X

CE 1180 Ex II (1) G

TLS RF LABEL

TLS-RF INVENTORY MEASUREMENT SYSTEM

Manufactured by: Veeder-Root Co.
Duncansville, PA 16635 U.S.A.

Associated Apparatus For Non-hazardous Locations,
Installed According To Descriptive System Document
331940-105 And Manual No. 577013-578.

0°C ≤ Ta ≤ +40°C

INPUT POWER RATINGS:
120/240 VAC, 50/60 Hz,
2.0 A Max
FORM NO.: *****
SERIAL NO.: *****

[Ex ia Ga] IIA
IECEx UL 08.0003X
IECEx ULD 08.0002X

TLS RF LABEL

TLS-XB INVENTORY MEASUREMENT SYSTEM

Manufactured By:
Veeder-Root Co.
Duncansville, PA 16635
U.S.A.

ASSOCIATED APPARATUS FOR NON HAZARDOUS LOCATIONS
INSTALLED IN ACCORDANCE WITH DESCRIPTIVE SYSTEM
DOCUMENT 331940-020 AND MANUAL NO. 577013-578.

0°C ≤ Ta ≤ +50°C

Um = 250 Volts
INPUT POWER RATINGS:
24 VDC
1.0 A Max
FORM NO.:
SERIAL NO.:

CE 1180 Ex II (1) G

[Ex ia] IIA
DEMKO 12 ATEX 1204670X
DEMKO 06 ATEX 137480X

TLS-XB LABEL

TLS-XB INVENTORY MEASUREMENT SYSTEM

Manufactured By:
Veeder-Root Co.
Duncansville, PA 16635
U.S.A.



TLS-XB TANK GAUGE SYSTEM, INSTALLED
IN ACCORDANCE WITH DESCRIPTIVE SYSTEM
DOCUMENT 331940-120 AND MANUAL
NO. 577013-578.

0°C ≤ Ta ≤ +50°C

Um = 250 Volts
INPUT POWER RATINGS:
24 VDC
1.0 A Max
FORM NO.:
SERIAL NO.:

[Ex ia Ga] IIA
IECEx UL 12.0022X
IECEx UL 08.0002X

TLS-XB LABEL



 Duncansville PA 16635 U.S.A.

 P/N 332235-XXX

INTRINSICALLY SAFE DEVICES FOR GROUP IIA
 HAZARDOUS LOCATIONS SECURITE INTINSEQUE.
 SEE DESCRIPTIVE SYSTEM DOCUMENT 331940-005
 AND MANUAL NO. 577013-578.

CE 1180  II 1G -40°C ≤ Ta ≤ +60°C
 Ex ia IIA T4
 DEMKO 06 ATEX 137478X
 DEMKO 06 ATEX 137480X

MANUAL 577013-578
 S/N 3XXXXX

TLS RF TRANSMITTER LABEL





 Duncansville PA 16635 U.S.A.

 P/N 332235-XXX



Ex ia IIA T4 Ga
 IECEx UL 06.0003X
 IECEx ULD 08.0002X
-40°C ≤ Ta ≤ +60°C

INTRINSICALLY SAFE DEVICES FOR GROUP IIA
 HAZARDOUS LOCATIONS. INSTALL IN ACCORDANCE
 WITH SYSTEM DESCRIPTIVE DOCUMENT 331940-105
 AND MANUAL NO. 577013-578.

S/N 3XXXXX

TLS RF TRANSMITTER LABEL

 Duncansville PA 16635 U.S.A.
 
 P/N 332425-XXX



 **WARNING**
 This device contains Lithium Batteries.
 To reduce risk of fire or explosion do not
 recharge, disassemble, crush, puncture,
 short external contacts, or dispose of in
 fire or water. 



INTRINSICALLY SAFE DEVICES FOR GROUP IIA
 HAZARDOUS LOCATIONS SECURITE INTINSEQUE.
 SEE DESCRIPTIVE SYSTEM DOCUMENT 331940-005
 AND MANUAL NO. 577013-578.

CE 1180  II 1G -40°C ≤ Ta ≤ +60°C
 Ex ia IIA T4
 DEMKO 06 ATEX 137478X
 DEMKO 06 ATEX 137480X

MANUAL 577013-578
 S/N 1XXXXX

TLS RF BATTERY PACK LABEL

 Duncansville PA 16635 U.S.A.
 
 P/N 332425-XXX

 **WARNING**
 This device contains Lithium Batteries.
 To reduce risk of fire or explosion do not
 recharge, disassemble, crush, puncture,
 short external contacts, or dispose of in
 fire or water. 

INTRINSICALLY SAFE DEVICES FOR GROUP IIA
 HAZARDOUS LOCATIONS. INSTALL IN ACCORDANCE
 WITH SYSTEM DESCRIPTIVE DOCUMENT 331940-105
 AND MANUAL NO. 577013-578.

Ex ia IIA T4 Ga
 IECEx UL 06.0003X
 IECEx ULD 08.0002X
-40°C ≤ Ta ≤ +60°C

S/N 1XXXXX

TLS RF BATTERY PACK LABEL

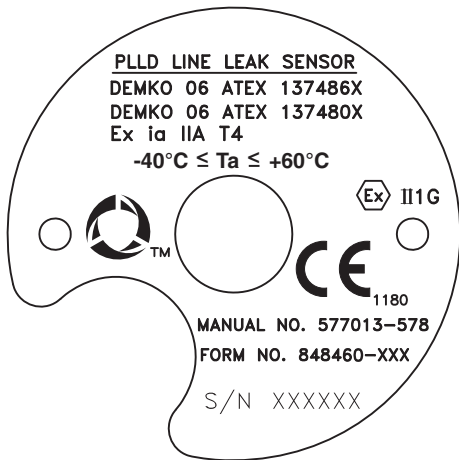

PLLD SENSOR LABEL

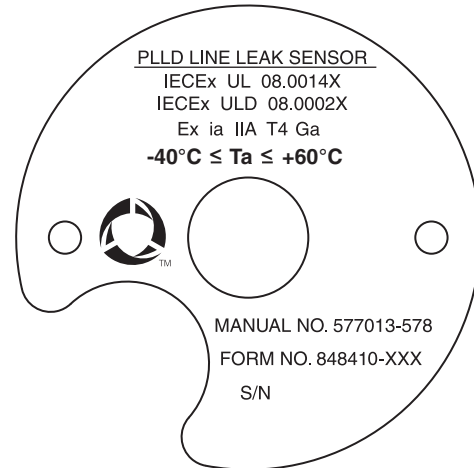

PLLD SENSOR LABEL

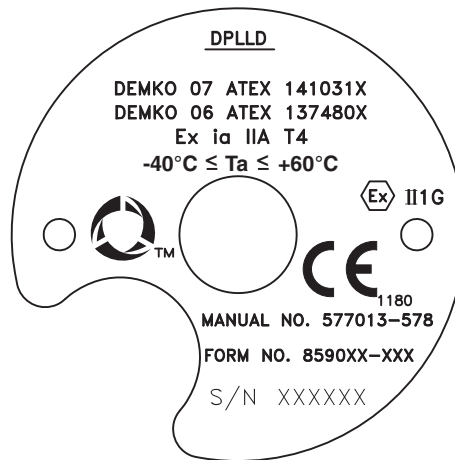

DIGITAL PLLD LABEL

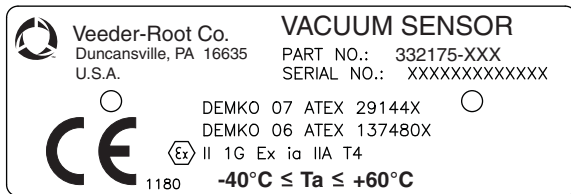

VACUUM SENSOR LABEL

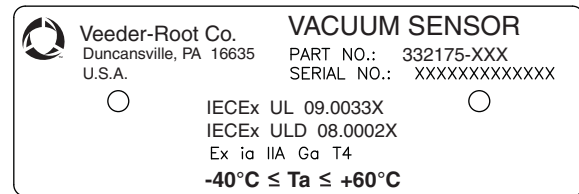

VACUUM SENSOR LABEL

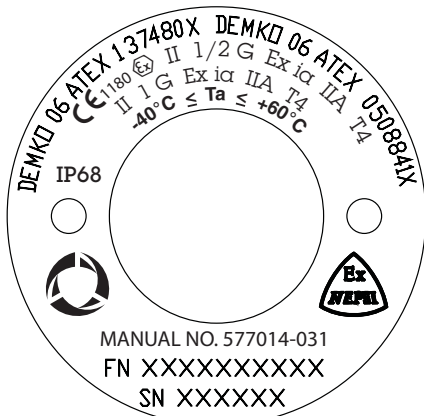

MAG PLUS PROBE & MAG SUMP SENSOR
ATEX LABEL

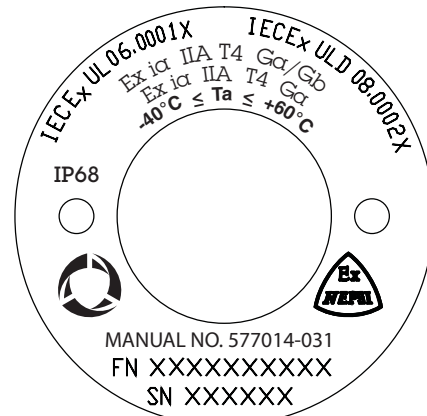

MAG PLUS PROBE & MAG SUMP SENSOR
IECEX LABEL

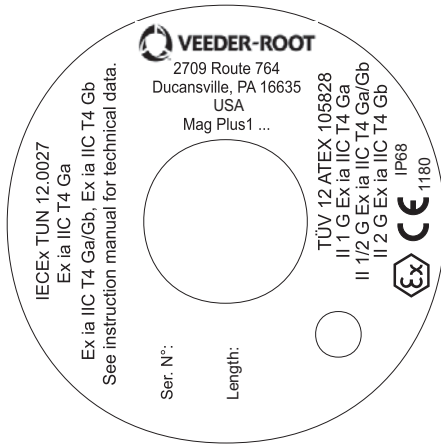

LABEL

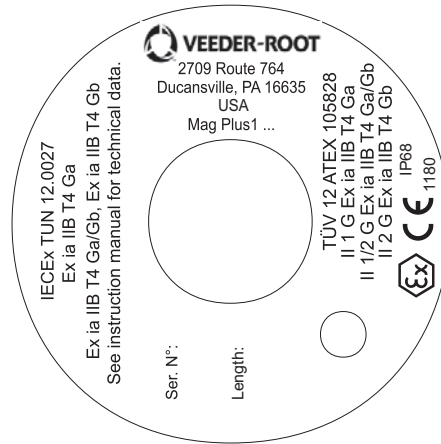

- Mag Plus1
- Mag Plus1 (V)
- Mag Plus1 Ethanol
- Mag Plus1 Interstitial
- Mag Plus1 Bio-Diesel
- Mag Plus1 AdBlue (N)
- Mag Plus1 LPG



LABEL

- Mag Plus1 Advanced
- Mag Plus1 Mag-FLEX

FORM NO.: 848100-002 Ex ia IIA T4 Gb
 SERIAL NO.: IECEx UL 13.0074X
 IECEx ULD 08.0002X

 (+) WHT (-) BLK
 (PE) GRN/YEL 

1180



 II 2 G Ex ia IIA T4 Gb IP 68 SIMPLE APPARATUS
 DEMKO 13 ATEX 1306057X DUAL CHANNEL SURGE
 DEMKO 06 ATEX 137480X PROTECTOR

WARNING
 POTENTIAL ELECTROSTATIC CHARGING HAZARD, SEE
 INSTALLATION INSTRUCTIONS,
 MANUAL NO. 577014-127

 **TM** TC = T4 -40°C ≤ Tα ≤ +60°C

Dual Channel

FORM NO.: 848100-001 Ex ia IIA T4 Gb
 SERIAL NO.: IECEx UL 13.0074X
 IECEx ULD 08.0002X

 (+) WHT (-) BLK
 (PE) GRN/YEL 

1180

 II 2 G Ex ia IIA T4 Gb IP 68 SIMPLE APPARATUS
 DEMKO 13 ATEX 1306057X SINGLE CHANNEL SURGE
 DEMKO 06 ATEX 137480X PROTECTOR

WARNING
 POTENTIAL ELECTROSTATIC CHARGING HAZARD, SEE
 INSTALLATION INSTRUCTIONS,
 MANUAL NO. 577014-127

 **TM** TC = T4 -40°C ≤ Tα ≤ +60°C

Single Channel

Surge Protector Labels

FORM NO.: 848100-003 Ex ia IIA T4 Gb
 SERIAL NO.: IECEx UL 13.0074X
 IECEx ULD 08.0002X

 (+) WHT (-) BLK

1180

 II 2 G Ex ia IIA T4 Gb IP 68 SIMPLE APPARATUS
 DEMKO 13 ATEX 1306057X CABLE SPLICE
 DEMKO 06 ATEX 137480X

WARNING
 POTENTIAL ELECTROSTATIC CHARGING HAZARD, SEE
 INSTALLATION INSTRUCTIONS,
 MANUAL NO. 577014-031

 **TM** TC = T4 -40°C ≤ Tα ≤ +60°C

Splice Kit

Appendix C - Field Wiring Diagrams

Example field wiring diagrams are shown on the next several pages followed by a sensor programming table for various TLS consoles.

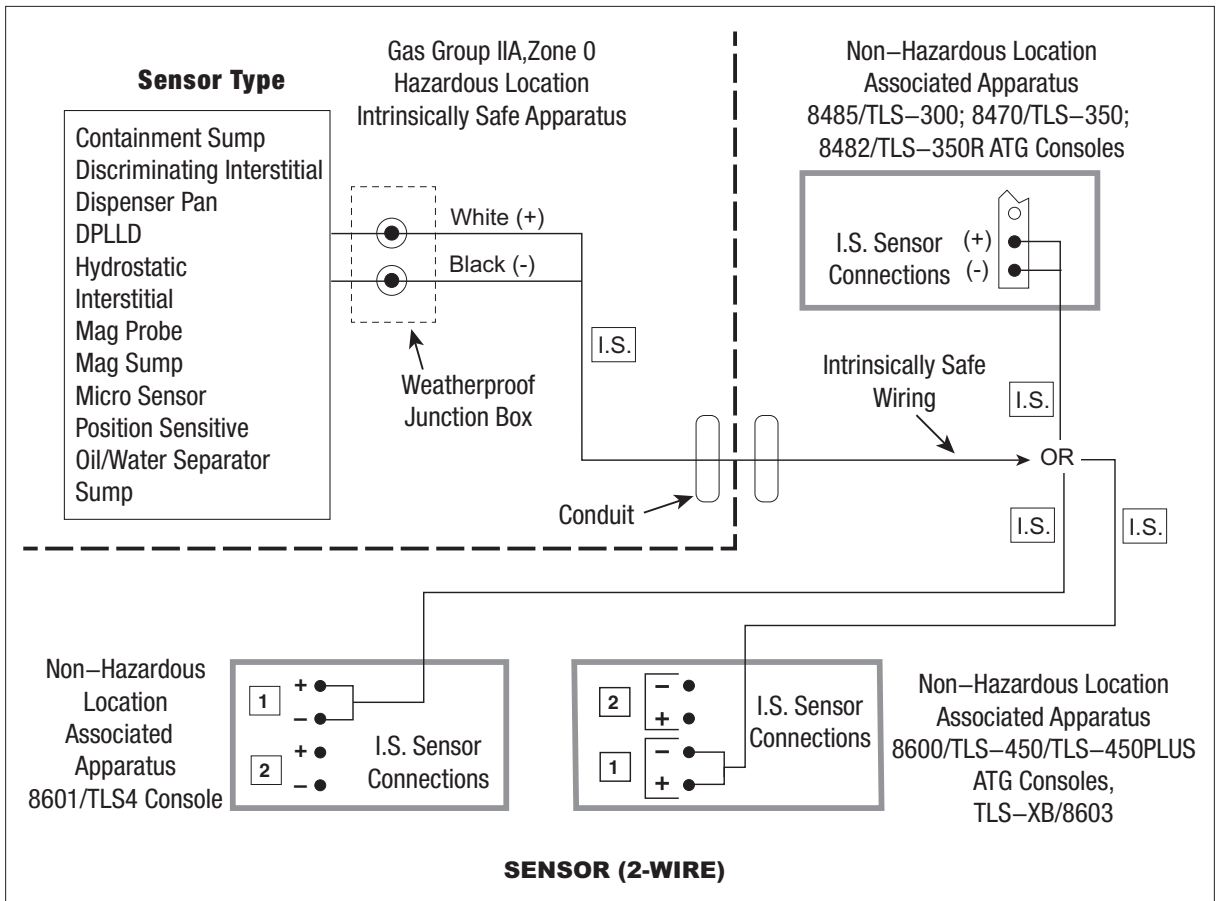

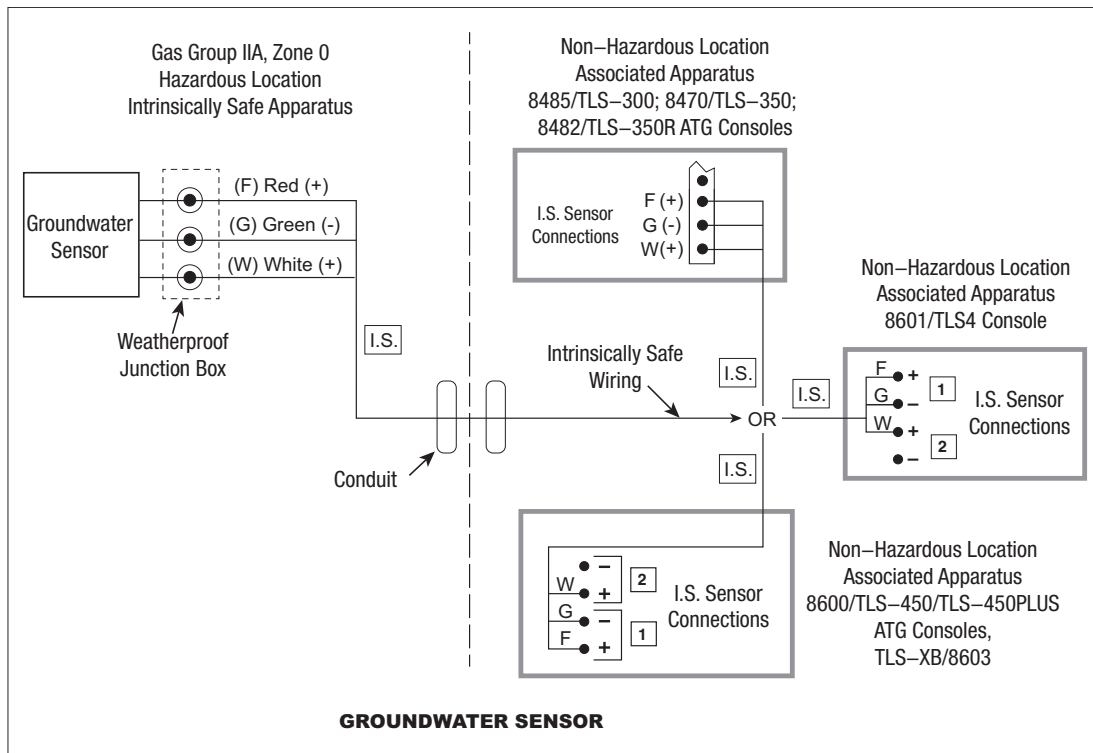
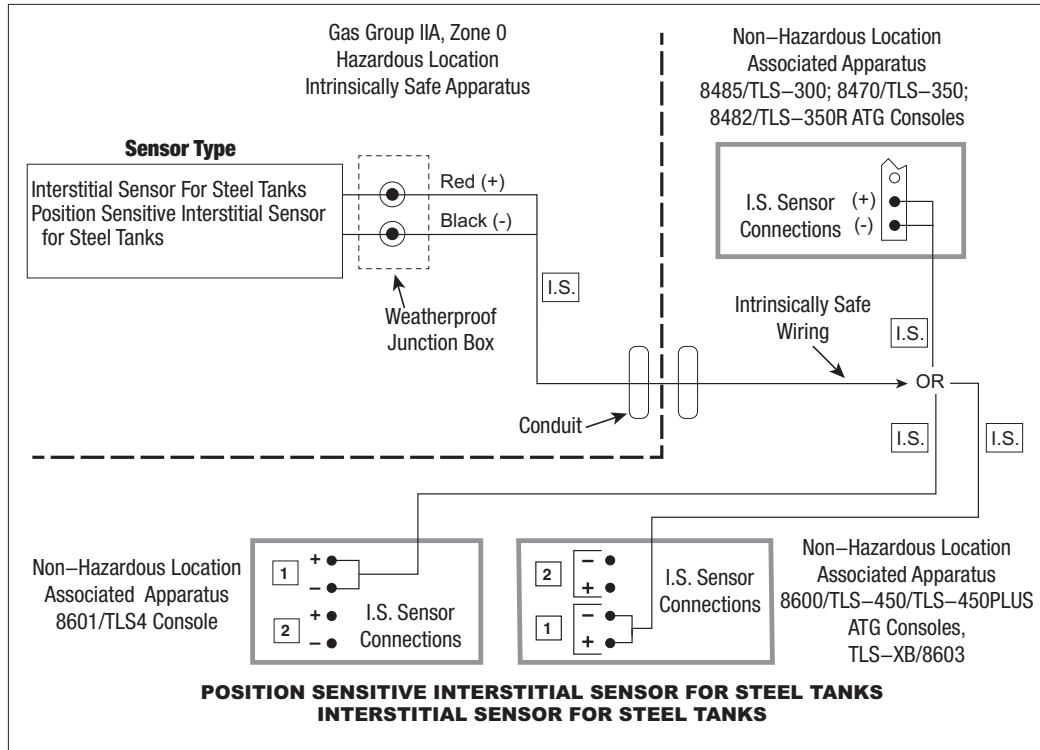

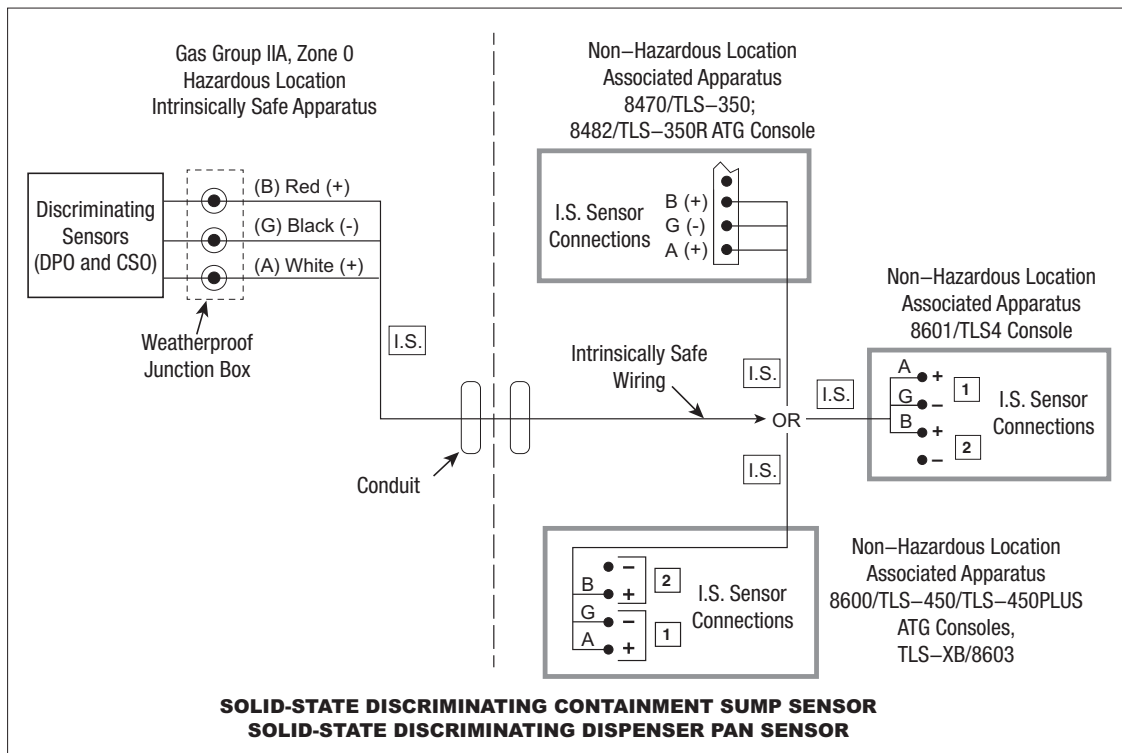
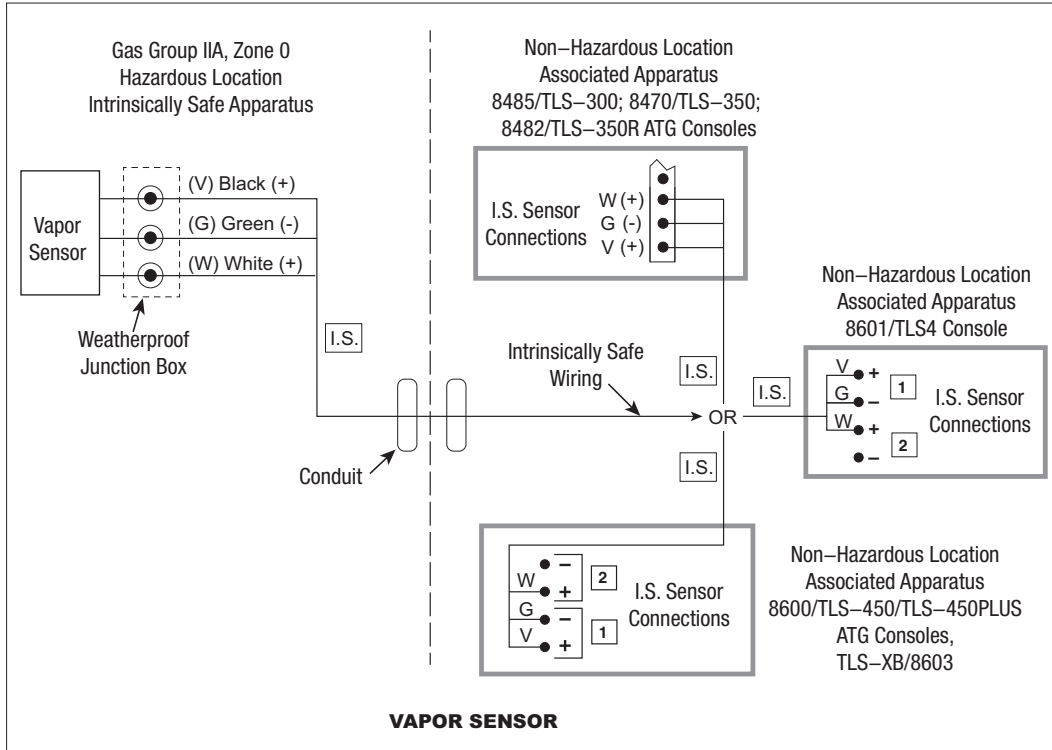

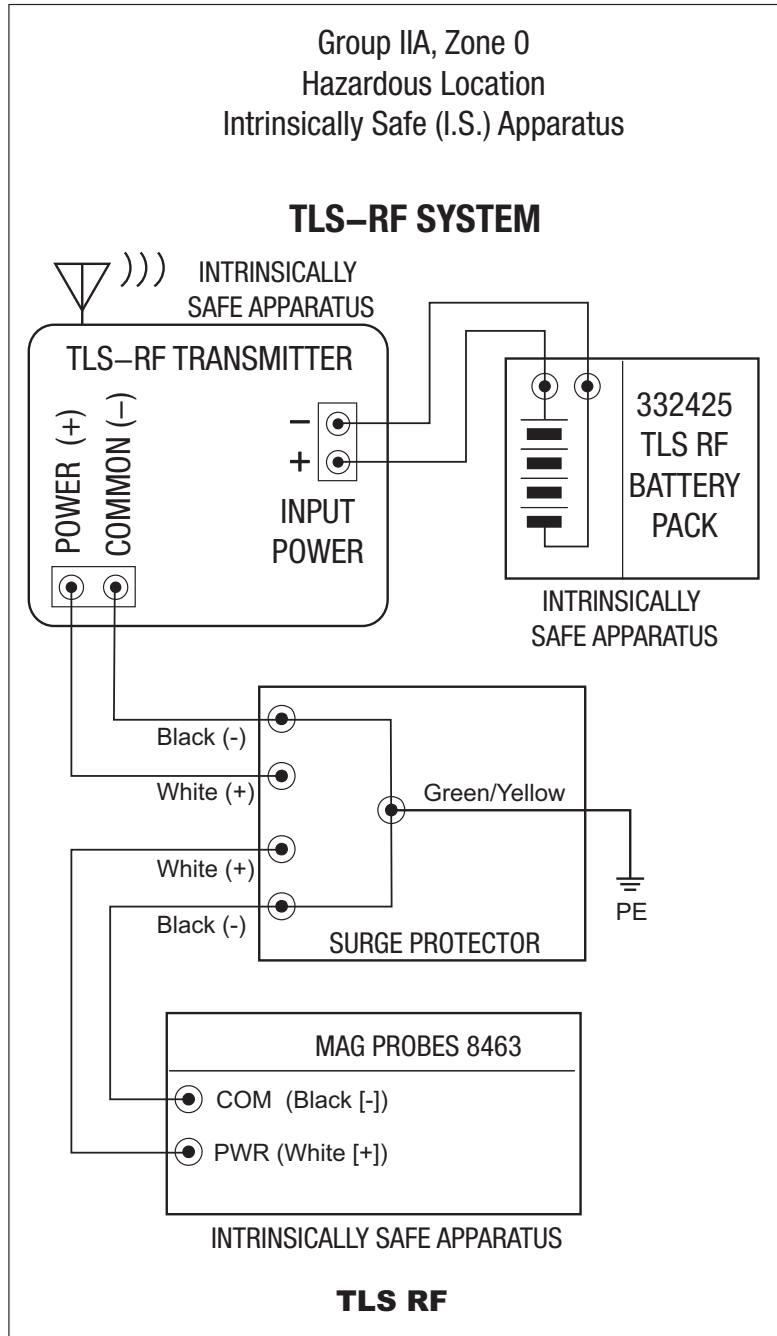

Appendix D - Sensor Programming Table

Sensor	Form Number	Sensor Category (Location)	TLS-3XX Series Sensor Type	TLS4/8601 Series TLS-450 and TLS-450PLUS Sensor Model
Discriminating Dispenser Pan and Sump Sensors - Standard	794380-322 (DPS), 794380-352 (CSS)	Sump/Pan	Liquid Sensor Setup: Sensor Type - Dual Float Discriminating	Device Setup Liquid Sensor: Model - Dual Float Discriminating
Discriminating Dispenser Pan and Sump Sensors - Optical	794380-320 (DPO), 794380-350 (CSO)	Sump/Pan	3-Wire C.L. Setup: Sensor Mode - Standard	Device Setup Type B Sensor: Model - Ultra/Z-1 (Standard)
Mag Sump Sensor	857080-XXX	Sump/Pan	Smart Sensor Setup: Sensor Category- Mag Sensor	Device Setup MAG Sensor
Solid-State Dispenser Pan and Containment Sump	794380-321 (DP); 794380-351 (CS)	Sump/Pan	2-Wire C.L. Setup: Sensor Type - Discrim Interstitial	Device Setup Type A Sensor: Model - Discrim. Interstitial
Piping Sump	794380-208	Sump/Pan	Liquid Sensor Setup: Sensor Type - Tri-State Liquid	Device Setup Liquid Sensor: Model - Tri-State
Position-Sensitive Sensor	794380-323	Sump/Pan	Liquid Sensor Setup: Sensor Type - Tri-State Liquid	Device Setup Liquid Sensor: Model - Tri-State
Discriminating Interstitial Sensor for Double-skin Fiberglass Tanks	794380-343	Annular Space	2-Wire C.L. Setup: Sensor Type - Discrim Interstitial	Device Setup Type A Sensor: Model - Discrim. Interstitial
Interstitial Sensors for Double-skin Fiberglass Tanks	794380-409	Annular Space	Liquid Sensor Setup: Sensor Type - Tri-State Liquid	Device Setup Liquid Sensor: Model - Tri-State
Interstitial High Alcohol Sensor for Double-skin Fiberglass Tanks	794380-345	Annular Space	2-Wire C.L. Setup: Sensor Type - Ultra 2	Device Setup Type A Sensor: Model - Ultra 2
Interstitial Sensors for Steel Tanks	794380-4X0	Annular Space	Liquid Sensor Setup: Sensor Type - Tri-State Liquid	Device Setup Liquid Sensor: Model - Tri-State
Position Sensitive Interstitial Sensor for Steel Tanks	794380-333	Annular Space	Liquid Sensor Setup: Sensor Type - Tri-State Liquid	Device Setup Liquid Sensor: Model - Tri-State
Interstitial High Alcohol Sensors for Steel Tanks	794380-430	Annular Space	Liquid Sensor Setup: Sensor Type - Tri-State Liquid	Device Setup Liquid Sensor: Model - Tri-State
MicroSensor	794380-344	Annular Space	2-Wire C.L. Setup: Sensor Type - Discrim Interstitial	Device Setup Type A Sensor: Model - Discrim Interstitial
Hydrostatic Reservoir	794380-301 (1 float)	Annular Space	Liquid Sensor Setup: Sensor Type - Tri-State Liquid	Device Setup Liquid Sensor: Model - Tri-State
	794380-303 (2 float)	Annular Space	Liquid Sensor Setup: Sensor Type - Dual Float Hydrostatic	Device Setup Liquid Sensor: Model - Dual Float Hydrostatic
Single-Point Mini Hydrostatic Sensor for Double-Skin Sumps	794380-304	Annular Space	Liquid Sensor Setup: Sensor Type - Tri-State Liquid	Device Setup Liquid Sensor: Model - Tri-State
Vapor	794390-700	Monitor Well	Vapor Sensor Setup	Device Setup Vapor Sensor
Groundwater	794380-62X	Monitor Well	Groundwater Sensor Setup	Device Setup Groundwater Sensor
Oil/Water Separator	794690-XXX	Oil/Water Separator Tank	Liquid Sensor Setup: Sensor Type - Dual Float Discriminating	Device Setup Liquid Sensor: Model -Dual Float Discriminating

