



Encore®

Installation Manual

MDE-3985AL

Computer Programs and Documentation

All Gilbarco Inc. and/or Veeder-Root Company computer programs (including software on diskettes and within memory chips) and documentation are copyrighted by, and shall remain the property of, Gilbarco Inc. and/or Veeder-Root Company. Such computer programs and documents may also contain trade secret information. The duplication, disclosure, modification, or unauthorized use of computer programs or documentation is strictly prohibited, unless otherwise licensed by Gilbarco Inc. and/or Veeder-Root Company.

Federal Communications Commission (FCC) Warning

This equipment has been tested and found to comply with the limits for a Class A digital device pursuant to Part 15 of the FCC Rules. These limits are designed to provide reasonable protection against harmful interference when the equipment is operated in a commercial environment. This equipment generates, uses, and can radiate radio frequency energy, and if not installed and used in accordance with the instruction manual, may cause harmful interference to radio communications. Operation of this equipment in a residential area is likely to cause harmful interference in which case the user will be required to correct the interference at his own expense. Changes or modifications not expressly approved by the manufacturer could void the user's authority to operate this equipment.

Approvals

Gilbarco is an ISO 9001:2008 registered company.

Underwriters Laboratories (UL):

UL File#	Products listed with UL
MH1941	All Gilbarco pumps and dispensers that bear the UL listing mark.
MH8467	Transac System 1000 and PAM 1000
E105106	Dell DHM Minitower
E165027	G-SITE and Passport Systems

California Air Resources Board (CARB):

Executive Order #	Product
G-70-52-AM	Balance Vapor Recovery
G-70-150-AE	VaporVac

National Conference of Weights and Measures (NCWM) - Certificate of Conformance (CoC):

Gilbarco pumps and dispensers are evaluated by NCWM under the National Type Evaluation Program (NTEP). NCWM has issued the following CoC:

CoC#	Product	Model #	CoC#	Product	Model #
02-019	Encore	Nxx	02-036	Legacy	Jxxx
02-020	Eclipse	Exx	02-037	G-SITE Printer (Epson)	PA0307
02-025	Meter - C Series	PA024NC10		G-SITE Distribution Box	PA0306
	Meter - C Series	PA024TC10		G-SITE Keyboard	PA0304
02-029	CRIND	—		G-SITE Mini Tower	PA0301
	TS-1000 Console	—		G-SITE Monitor	PA0303
	TS-1000 Controller	PA0241		G-SITE Printer (Citizen)	PA0308
02-030	Distribution Box	PA0242	02-038	C+ Meter	T19976
	Meter - EC Series	PA024EC10	02-039	Passport	PA0324
	VaporVac Kits	CV	02-040	Ecometer	T20453
			05-001	Titan	KXXY Series

Trademarks

Non-registered trademarks

Applause™ Media System	Gilbert™	Optimum™ Series	Tank Monitor™
CIM™	G-SITE™	PAM™	TCR™
C-PAM™	G-SITE® Link™	PAM™ 1000	The Advantage™ Series
Dimension™ Series	G-SITE® Lite™	PAM™ 5000	Titan™
Ecometer™	Highline™	Passport™	Trimline™
Eclipse™	Horizon™	SMART Connect™	Ultra-Hi™
ECR™	InfoScreen™	SMART CRIND™	ValueLine™
e-CRIND™	Insite360™	SMART Meter™	
EMC™	Making Things Better™ SmartPad™		
FlexPay™	MPD™	Super-Hi™	
G-CAT™	MultiLine™	Surge Management System™	

Registered trademarks

CRIND®
Encore®
Gilbarco®
Legacy®
Performer®
Transac®
Transac® System 1000
TRIND®
VaporVac®

Service mark

GOLDSM

Additional U.S. and foreign trademarks pending.

All product names, logos, and brands are the property of their respective owners and are for identification purposes only. Use of these names, logos, and brands does not imply endorsement.

Table of Contents

1 – Introduction	1-1
Purpose	1-1
Related Documents	1-1
Balance In-station Diagnostic (ISD) Flowmeter Option	1-3
Americans with Disabilities Act (ADA) Requirements	1-4
Encore Shipping Weight and Model Codes: N-X-X	1-5
Shipping Weights	1-5
Model Codes	1-5
Abbreviations and Acronyms	1-7
Common Terms	1-8
2 – Important Safety Information	2-1
3 – Hazardous Locations	3-1
Classifying Hazardous Locations	3-1
Important Considerations for DEF Dispensers	3-2
4 – Preliminary Installation Information	4-1
Replacing the Advantage Series Units with Encore Units	4-1
Required Equipment and Materials	4-1
Dispensing Gasoline/Ethanol Blends	4-1
Important Consideration for Field Electrical Conduits Placement	4-2
Important Consideration for Sizing STPs	4-3
Important Requirements for E25/E40 and E85 Units	4-3
Read NFPA 30A and NFPA 70	4-3
Important Considerations When Changing Fuel Types	4-4
Installation Considerations for Units with Ecometers	4-6
Software Considerations for Units with Ecometers	4-6
Installation Checklists	4-7
Preparing for Installation	4-7
Gaining Access to and from Encore Cabinet	4-9
Before Mounting Unit on Fuel Island	4-9
Verifying and Determining Plumbing Requirements	4-10
Adapting Pit Box	4-10
Units with Ground Fault Interrupt (GFI)	4-11
Installing Conduit at Pump/Dispenser	4-11
Installing Units with Conduit Entry in Side of Electronics Cabinet	4-12
5 – Unit Configuration	5-1
Multi Product (MPD) Configuration	5-1
Dispenser (MPD) Configuration	5-1
Dispenser MPD Piping to Hose Fitting Configurations	5-3
Ultra-Hi Configuration	5-4
Dispenser Ultra-Hi Configuration	5-4
Dispenser Ultra-Hi Piping to Hose Fitting Configuration	5-7

Table of Contents

Pump (MPD) Configuration	5-8
Pump (MPD) Piping to Hose Fitting Configuration	5-9
Blender Configuration	5-10
Dispenser Blender Configuration	5-10
Dispenser Blender Piping to Hose Fitting Configuration	5-16
Pump Blender Configuration	5-19
Encore Pump Blender Piping to Hose Fitting Configuration	5-20
6 – Installing Units on Island	6-1
<hr/>	
Mounting Unit to Island	6-1
Lifting Encore Units	6-1
Connecting Pump/Dispenser Inlet Pipes	6-5
Connecting Vapor Return Line to Vapor Shear Valve	6-12
Anchoring Pump/Dispenser to Island	6-13
DEF Dispensers - Skid Tank Interface	6-14
7 – Installing Conduit and Wiring in Unit	7-1
<hr/>	
Installing Conduit Within Unit	7-1
For Installations in Canada	7-2
Installing J-box	7-5
Preparing J-box Field Conduit	7-7
Installing Conduit Through Vapor Barrier	7-11
Installing Conduit Through Side of Electronics Cabinet	7-13
Installing Wiring	7-15
Operating Environment	7-15
Heater Load Table	7-15
Wiring External to Dispenser	7-16
Wiring Internal to Dispenser	7-18
Completing Field Wiring	7-23
Optional Conduits and Wiring	7-23
Potting Conduit Stubs	7-26
Potting up to Unit	7-26
Potting Within Unit	7-26
Connecting to ISD Vapor Flow Meter	7-29
At Dispensing Unit	7-29
Epoxy Sealing	7-30
8 – Installing Breakaways, Hoses, Swivels, and Nozzles	8-1
<hr/>	
Units Without Hose Retractors	8-2
Units with Hose Retrievers or Extended Reach	8-3
DEF Dispensers - ZVA™ DEF Nozzle	8-5
DEF Nozzle (M10257B001 and M10257B002)	8-5
Dispenser DEF Strainer (M10820A001)	8-6
Hose Breakaway/Swivel (M10258B001)	8-6
9 – Completing Installation	9-1
<hr/>	
Do Not Turn on AC Power	9-1
Installation Checklists	9-2
Mechanical and Hydraulic Related Items	9-2
Electrical Related Items	9-3

Purging Air from System and Testing	9-5
About Purging System	9-5
Individual Product Line Purging Procedure	9-5
Individual Meter Purging Procedure	9-5
Post Service Purging Procedures	9-6
For New Dispensers (Purging Through Shear Valve)	9-6
Special Steps for Purging Air from Underground Lines	9-7
For New and Existing Pumps and Dispensers with Fuel in Lines (Purging Through Nozzle)	9-8
Verifying Shear Valve, Nozzle, and Dispenser Shutoff Operation	9-10
Calibration Procedure for Encore 300 Units	9-10
Calibration Procedure for Encore 500/500 S/700 S/900 Units	9-10
Encore 500/500 S/700 S/900 (Gallon Unit of Measure)	9-11
Calibration and Accuracy Checks - DEF Dispensers	9-12
Programming Prover Can	9-12
10 – Reference Information	10-1
<hr/>	
Reference Contents	10-1
Installation Differences when Replacing The Advantage Series	10-2
Electrical Requirements	10-3
Plumbing Requirements	10-16
Fluid Handling Components for DEF	10-16
Recommended Hose Material for DEF	10-16
Skid Mounted Tanks for DEF Dispensers	10-17
Acceptable Pipe Material for DEF	10-17
Pipe Installation	10-17
Pipe Size	10-18
Appendix: Elevation and Foundation Diagrams	A-1
<hr/>	
Index	Index-1

This page is intentionally left blank.

1 – Introduction

Purpose

This manual contains step-by-step instructions for installing Gilbarco® Encore® series pumps and dispensers, including the “S” series units. Installation of these pumps as a group is similar except for some differences in field wiring, calibration, and hydraulic connections. This manual does not include site preparation instructions (for site preparation instructions, refer to *MDE-3802 Encore and Eclipse® Site Preparation Manual*). After the installation is complete, a Gilbarco Authorized Service Contractor (ASC) must commission the unit to activate the warranty. Reference information to complete *MDE-4226 Encore/Eclipse Installation Checklist (Form A)* is provided in this manual [for Diesel Exhaust Fluid (DEF) units, you must complete *MDE-4897 Installation Checklist for Diesel Exhaust Fluid (DEF) Units (Form A)*]. Proper completion of the checklist is required for commissioning of the unit. For more information, refer to “[Installation Checklists](#)” on [page 4-7](#).

IMPORTANT INFORMATION

Read and follow all safety precautions outlined in “[Important Safety Information](#)” on [page 2-1](#) and save it in a readily accessible location.

For additional safety information on DEF, refer to the Petroleum Equipment Institute (PEI) document “RP1100 Recommended Practices for the Storage and Dispensing of DEF”.

Gilbarco offers standard fuel Encore models that are listed under UL® 87 and suitable for use with standard fuels, such as gasoline, gasoline with up to E10, diesel, diesel with up to B5, and kerosene. Encore alternate fuel models are listed under UL 87A, 87B and suitable for use with fuels, such as gasoline with up to E25/E40, gasoline with up to E85, and diesel with up to B20. Encore DEF models are listed under UL 87C for DEF.

Related Documents

Document Number	Title	GOLD SM Library
FE-321	Field Wiring Diagram Gilbarco STP Isolation Relay Box PA0287, 120 VAC	Engineering Diagrams
FE-353	Field Wiring Diagram Encore 550 Dispensers, 120/240 VAC	<ul style="list-style-type: none"> • Encore and Eclipse Installers • Engineering Diagrams
FE-363	Field Wiring Diagram Encore 500/700/900 (M07555 Power Supply Only)	<ul style="list-style-type: none"> • Encore and Eclipse Installers • Engineering Diagrams
FE-364	Field Wiring Diagram for Encore 300	<ul style="list-style-type: none"> • Encore and Eclipse Installers • Engineering Diagrams

Document Number	Title	GOLD SM Library
MDE-2755	STP Control and Dispenser Isolation Relay Box (PA0287)	<ul style="list-style-type: none"> Encore and Eclipse Encore and Eclipse Installers Advantage[®] and Legacy[®]
MDE-3802	Encore and Eclipse Site Preparation Manual	<ul style="list-style-type: none"> Encore and Eclipse Encore and Eclipse Installers Footprint and Elevation Site Prep
MDE-3804	Encore and Eclipse Start-up/Service Manual	<ul style="list-style-type: none"> Encore and Eclipse Service Manual
MDE-3860	Programming Quick Reference Guide	<ul style="list-style-type: none"> Encore and Eclipse Encore and Eclipse Installers
MDE-4039	Encore 300 Programming Quick Reference Card	<ul style="list-style-type: none"> Encore and Eclipse Encore and Eclipse Installers
MDE-4084	Encore Junction Box Retrofit Kit M01483K00X Installation Instructions	<ul style="list-style-type: none"> Encore and Eclipse Encore and Eclipse Installers
MDE-4166	The Advantage Series Unit to Encore Series Island Adapter Kit (M03064K001) Installation Manual	<ul style="list-style-type: none"> Encore and Eclipse Encore and Eclipse Installers
MDE-4226	Encore/Eclipse Installation Checklist (Form A)	<ul style="list-style-type: none"> Encore and Eclipse Encore and Eclipse Installers Gilbarco Forms
MDE-4227	Encore/Eclipse Start-up Checklist (Form B)	<ul style="list-style-type: none"> Encore and Eclipse Encore and Eclipse Installers Gilbarco Forms
MDE-4228	Encore Commissioning Checklist (Form C)	<ul style="list-style-type: none"> Encore and Eclipse Gilbarco Forms
MDE-4281	Calibration Quick Reference Card Encore 300/500/550, and Eclipse Units	<ul style="list-style-type: none"> Encore and Eclipse Encore and Eclipse Installers Service Manual
MDE-4473	Encore Dispenser Water Intrusion Prevention Kit	Encore and Eclipse
MDE-4701	Side Conduit Entry Hardware Kit (M07838K001) Installation Guide for Encore Units	Encore and Eclipse
MDE-4897	Installation Checklist for Diesel Exhaust Fluid (DEF) Units (Form A)	<ul style="list-style-type: none"> Encore and Eclipse Encore and Eclipse Installers
MDE-4898	Start-up Checklist for Diesel Exhaust Fluid (DEF) Units (Form B)	<ul style="list-style-type: none"> Encore and Eclipse Encore and Eclipse Installers
MDE-4899	Commissioning Checklist for Diesel Exhaust Fluid (DEF) Units (Form C)	<ul style="list-style-type: none"> Encore and Eclipse Encore and Eclipse Installers
MDE-4917	FlexPay [™] Connect Distribution Box Installation Manual	FlexPay Connect
MDE-4978	Installation Instructions for Encore [®] 300/500/500S/700S E40 Retrofit Kit (M12658K001) and E85 Retrofit Kit (M19499K001)	Encore and Eclipse
MDE-5153	Using Conduit Template (M13952K001) to Mount the Electrical Conduits	<ul style="list-style-type: none"> Encore and Eclipse Installers Site Prep

Document Number	Title	GOLD SM Library
MDE-5356	Encore 900 Start-Up and Service Manual	<ul style="list-style-type: none"> • Encore and Eclipse • Encore and Eclipse Installers • Service Manual
MDE-5369	FlexPay IV (with Omnia) Programming and Service Manual	<ul style="list-style-type: none"> • FlexPay IV • Service Manual
PT-1969	Encore 900 Pump and Dispenser Illustrated Parts Manual	<ul style="list-style-type: none"> • Encore and Eclipse • Encore and Eclipse Installers • Parts Manual
PT-1971	Encore 900 Recommended Spare Parts Manual	<ul style="list-style-type: none"> • Encore and Eclipse • Service Manual • Parts Manual
577013-796	ISD Vapor Flow Meter Installation Guide	Enhanced Vapor Recovery Solutions

Balance In-station Diagnostic (ISD) Flowmeter Option

For details regarding the requirements for balanced ISD flowmeter upgrades to your site, refer to Veeder-Root® documents “MSR 08.10.A” and “MSR 08.04.A”.

*Note: This option is not available with suction units. **ADDITIONAL** site-specific equipment **REQUIRED** to meet **ALL** ISD requirements is available from Veeder-Root (1-800-873-3313).*

Americans with Disabilities Act (ADA) Requirements

IMPORTANT INFORMATION

To meet the reach requirements as specified by the ADA, the island of the dispenser must not be higher than 6 inches tall.

Figure 1-1: ADA Requirements

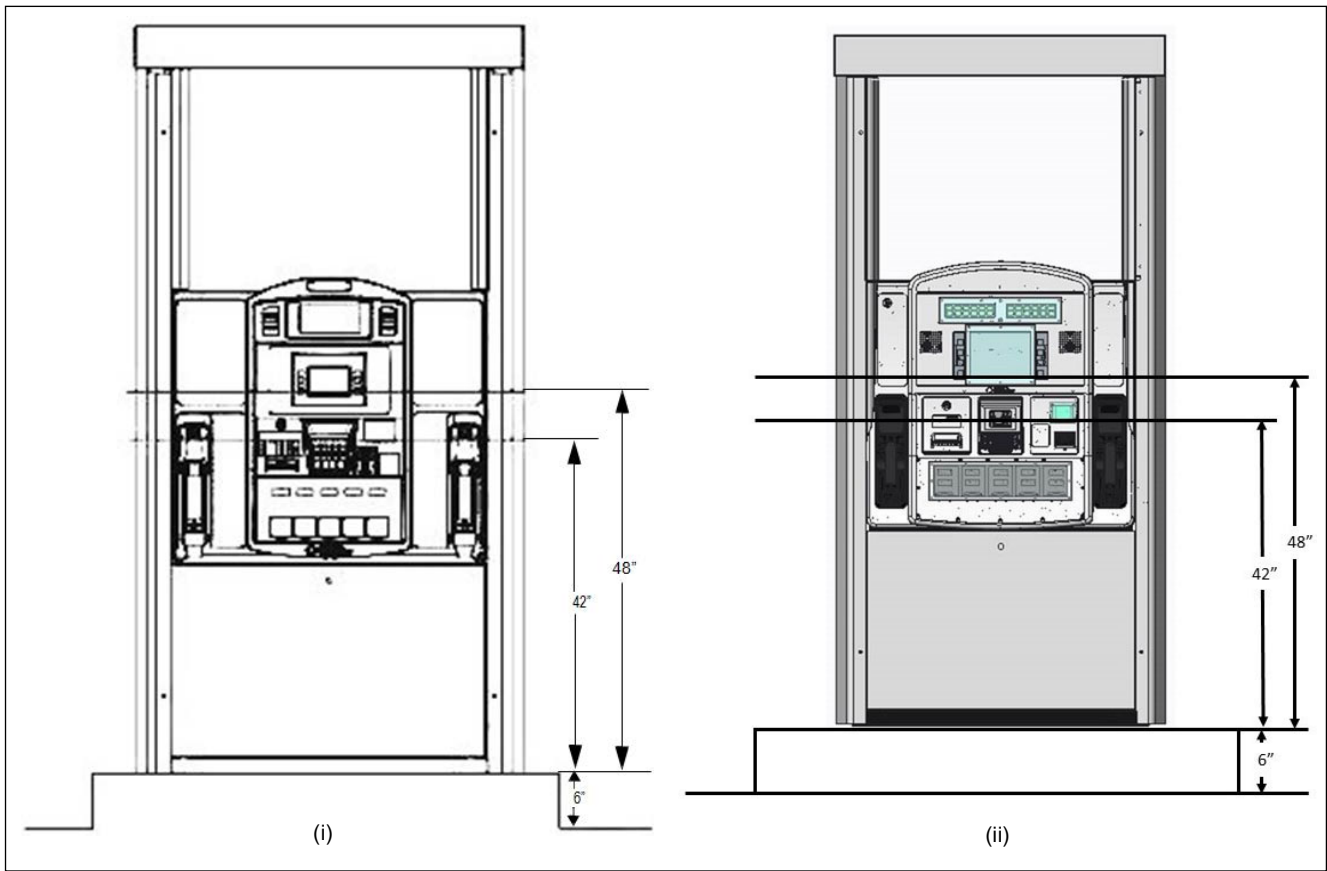

Encore Shipping Weight and Model Codes: N-X-X

Shipping Weights

The shipping weight for a standard Encore dispenser is about 800 lbs (363 kg). Additional shipping weight is added when options are included. The following table provides shipping weights for the dispenser and applicable option(s):

Equipment	Weight
Dispenser	850 lbs (386 kg)
Ultra-Hi™ (dual)	710 lbs (322 kg)
VaporVac® option	200 lbs(91 kg) additional
Pumping Unit option	90 lbs (41 kg), per grade
DEF Dispenser only	860 lbs (390 kg)

Model Codes

While new models have their serial number and model plate located inside the electronics cabinet, in older units, they are located at the bottom of the dispenser directly above the serial number. The model number is a two-letter and one-numeric digit model code stamped onto the model/serial plate. This code shows the configuration of the Encore unit.

For example, a serial plate stamp with model code “NG2” signifies that the unit is an Encore single-hose 3-grade pump where:

- N represents an Encore unit**
- G represents a Single-hose**
- 2 represents a 3-grade Pump + 1**

To determine the model code on a Gilbarco dispenser, refer to the following table:

Note: Not all model types are available in Encore 300/500/500 S/700 S/900 series.

Encore 300/500/700/900 and Encore S Series

N	X	X
Encore	A = Multi-hose Dispenser	0 = 1-grade
		1 = 2-grade
		2 = 3-grade
		3 = 4-grade
		4 = DEF only
C = Multi-hose Pump		0 = 1-grade
		1 = 2-grade
		2 = 3-grade
		3 = 4-grade
F = Multi-Hose Universal Blender		0 = 5 Grade 3-2 (2 hose) Multi-Hose Universal Blender
		1 = 5 Grade 3-1-1 (3 hose) Multi-Hose Universal Blender
		2 = 5 Grade 3-1+1 (3 hose)* Multi-Hose Universal Blender
		4 = 5 Grade 3-1+1 (3 hose)** Multi-Hose Universal Blender
		6 = 6 Grade 3-2+1 (4 hose) Multi-Hose Universal Blender
		7 = 6 Grade 4-1+1 (3 hose) Multi-Hose Universal Blender
		8 = 5 Grade 3-1-1 (3 hose) Multi-Hose Universal Blender
		* Center hose right of CIM ** Center hose left of CIM
		G = Single-hose
1 = 3-grade + 1 Dispenser		
2 = 3-grade Pump		
3 = 3-grade Pump + 1		
4 = 2-grade Single-hose MPD®		
5 = 2-grade Single-hose Pump		
J = Multi-hose Blender		0 = 3-grade Blender Dispenser
		1 = 3-grade Blender Pump
		2 = 4-grade Blender + 1 Dispenser
		3 = 4-grade Blender + 1 Pump
		4 = 3 + 2 Grade Blender Dispenser
L = X+1 Blender		0 = 2 + 1 Grade Blender Dispenser
		1 = 3 + 1 Grade Blender Dispenser
		2 = 4 + 1 Grade Blender Dispenser
		3 = 3 + 1 + 1 Grade Blender Dispenser
		4 = 2 + 1 Grade Blender Pump
		5 = 3 + 1 Grade Blender Pump
		6 = 4 + 1 Grade Blender Pump
		8 = 5 + 1 Grade Blender Pump
N = X+0 Blender		1 = 3 + 0 Grade Blender Dispenser
		2 = 4 + 0 Grade Blender Dispenser
		3 = 5 + 0 Grade Blender Dispenser
		5 = 3 + 0 Grade Blender Pump
		6 = 4 + 0 Grade Blender Pump
		7 = 5 + 0 Grade Blender Pump
		P = Ultra-Hi Flow
4 = Ultra-Hi Combo		
5 = Ultra-Hi Satellite		
6 = Ultra-Hi Master Dispenser - Single-sided Dual Product Unit		
8 = Ultra-Hi Satellite Dispenser - Single-sided Dual Product Unit		
R = Special		0 = No Hydraulics
		1 = Robot
		2 = Simulator
		3 = Pumpless Pump
		4 = No Electronics

Abbreviations and Acronyms

Term	Description
ADA	Americans with Disabilities Act
ASC	Authorized Service Contractor
ASTM	American Society for Testing and Materials
ATC	Automatic Temperature Compensation
AWG	American Wire Gauge
BRCM	Back Room Communication Module
CAT5	Category 5
CC	Command Code
CCP	Cloud Connection Processor
CEC	Canadian Electrical Code
CIM™	Customer Interface Module
CoC	Certificate of Conformance
CRIND®	Card Reader in Dispenser
DCM	Dispenser Communication Module
DEF	Diesel Exhaust Fluid
FCB	FlexPay Control Board
FCC	Federal Communications Commission
GFI	Ground Fault Interrupt
GLRE	Gilbarco Long Range Ethernet®
GOLD	Gilbarco Online Documentation
GSoM	Gilbarco System-on-Module
HDPE	High Density Polyethylene
IFSF	International Forecourt Standards Forum
IP	Internet Protocol
ISD	In-station Diagnostic
J-box	Junction Box
LAN	Local Area Network
MPD	Multi Product Dispenser
NCWM	National Conference on Weights and Measures
NEC®	National Electrical Code
NFPA	National Fire Protection Association
NPT	<ul style="list-style-type: none"> • National Pipe Taper • National Pipe Thread
NTEP	National Type Evaluation Program
PEI	Petroleum Equipment Institute
POS	Point of Sale
PPU	Price per Unit
PTFE	PolyTetraFluoroEthylene (chemical name for Teflon®)
PVC	Polyvinyl Chloride
STP	Submersible Turbine Pump
TBM 2	Two-wire Board Module 2
TCP/IP	Transmission Control Protocol/Internet Protocol

Term	Description
TLS	Tank Level Sensor
TRIND®	Transmitter/Receiver in Dispenser
UL	Underwriters Laboratories
UPM	Universal Payment Module
UST	Underground Storage Tank
W&M	Weights and Measures

Common Terms

Term	Description
CIM Door	CIM Door - Main pump and CRIND displays are mounted on this door.
Combo	This unit is configured as Master on one side and Satellite on the other.
DEF	A clear, colorless, non-toxic, non-flammable, and non-combustible liquid. It is made up of 32.5% urea with the balance distilled or de-ionized water. Urea and water are completely miscible and do not separate in storage. DEF is mildly corrosive.
Dispenser	A dispensing device that receives fuel under pressure from the Submersible Turbine Pump (STP) at the Underground Storage Tank (UST).
Ecometer™	A twin screw hydraulic/electronic device that measures the flow delivered from the UST to the end user
Grade	Fuel that is dispensed and has an assigned price.
Listed	Products bearing authorized Listing Mark of Underwriters Laboratories (UL) as manufacturer's declaration that product complies with UL's requirements in accordance with terms of UL's Listing and Follow-up Service agreement.
Master	This unit dispenses fuel to one saddle tank and to a second saddle tank through a satellite unit.
Product	Refers to fuel in storage tank.
Pump	A dispensing device that utilizes a self-contained pumping unit and motor to move fuel from the storage tank using suction.
Satellite	A dispensing unit that receives product from, and registers at the Master unit allowing both saddle tanks on a vehicle to be filled at the same time.
SMART Meter	Electronic device that measures the flow of product from the UST to the end user.
Teflon	The DuPont™ trade name for PolyTetraFluoroEthylene (PTFE).

2 – Important Safety Information

Notes: 1) Save this Important Safety Information section in a readily accessible location.

2) Although DEF is non-flammable, Diesel is flammable. Therefore, for DEF cabinets that are attached to Diesel dispensers, follow all the notes in this section that pertain to flammable fuels.



This section introduces the hazards and safety precautions associated with installing, inspecting, maintaining, or servicing this product. Before performing any task on this product, read this safety information and the applicable sections in this manual, where additional hazards and safety precautions for your task will be found. Fire, explosion, electrical shock, or pressure release could occur and cause death or serious injury, if these safe service procedures are not followed.

Preliminary Precautions

You are working in a potentially dangerous environment of flammable fuels, vapors, and high voltage or pressures. Only trained or authorized individuals knowledgeable in the related procedures should install, inspect, maintain, or service this equipment.

Emergency Total Electrical Shut-Off

The first and most important information you must know is how to stop all fuel flow to the pump/dispenser and island. Locate the switch or circuit breakers that shut off all power to all fueling equipment, dispensing devices, and Submerged Turbine Pumps (STPs).

⚠ WARNING	
	The EMERGENCY STOP, ALL STOP, and PUMP STOP buttons at the cashier's station WILL NOT shut off electrical power to the pump/dispenser. This means that even if you activate these stops, fuel may continue to flow uncontrolled.
	You must use the TOTAL ELECTRICAL SHUT-OFF in the case of an emergency and not the console's ALL STOP and PUMP STOP or similar keys.

Total Electrical Shut-Off Before Access

Any procedure that requires access to electrical components or the electronics of the dispenser requires total electrical shut off of that unit. Understand the function and location of this switch or circuit breaker before inspecting, installing, maintaining, or servicing Gilbarco equipment.

Evacuating, Barricading, and Shutting Off

Any procedure that requires access to the pump/dispenser or STPs requires the following actions:



- An evacuation of all unauthorized persons and vehicles from the work area
- Use of safety tape, cones, or barricades at the affected unit(s)
- A total electrical shut-off of the affected unit(s)

Read the Manual

Read, understand, and follow this manual and any other labels or related materials supplied with this equipment. If you do not understand a procedure, call the Gilbarco Technical Assistance Center (TAC) at 1-800-743-7501. It is imperative to your safety and the safety of others to understand the procedures before beginning work.

Follow the Regulations

Applicable information is available in National Fire Protection Association (NFPA) 30A; Code for Motor Fuel Dispensing Facilities and Repair Garages, NFPA 70®; National Electrical Code (NEC), Occupational Safety and Health Administration (OSHA) regulations and federal, state, and local codes. All these regulations must be followed. Failure to install, inspect, maintain, or service this equipment in accordance with these codes, regulations, and standards may lead to legal citations with penalties or affect the safe use and operation of the equipment.

Replacement Parts

Use only genuine Gilbarco replacement parts and retrofit kits on your pump/dispenser. Using parts other than genuine Gilbarco replacement parts could create a safety hazard and violate local regulations.

Federal Communications Commission (FCC) Warning

This equipment has been tested and found to comply with the limits for a Class A digital device pursuant to Part 15 of the FCC Rules. These limits are designed to provide reasonable protection against harmful interference when the equipment is operated in a commercial environment. This equipment generates, uses, and can radiate radio frequency energy, and if not installed and used in accordance with the instruction manual, may cause harmful interference to radio communications. Operation of this equipment in a residential area is likely to cause harmful interference in which case the user will be required to correct the interference at his own expense. Changes or modifications not expressly approved by the manufacturer could void the user's authority to operate this equipment.

Safety Symbols and Warning Words



This section provides important information about warning symbols and boxes.

Alert Symbol

 This safety alert symbol is used in this manual and on warning labels to alert you to a precaution which must be followed to prevent potential personal safety hazards. Obey safety directives that follow this symbol to avoid possible injury or death.

Signal Words

These signal words used in this manual and on warning labels tell you the seriousness of particular safety hazards. The precautions below must be followed to prevent death, injury, or damage to the equipment:

-  **DANGER:** Alerts you to a hazard or unsafe practice which will result in death or serious injury.
-  **WARNING:** Alerts you to a hazard or unsafe practice that could result in death or serious injury.
-  **CAUTION** with Alert symbol: Designates a hazard or unsafe practice which may result in minor injury.
- CAUTION** without Alert symbol: Designates a hazard or unsafe practice which may result in property or equipment damage.

Working With Fuels and Electrical Energy Prevent Explosions and Fires

Fuels and their vapors will explode or burn, if ignited. Spilled or leaking fuels cause vapors. Even filling customer tanks will cause potentially dangerous vapors in the vicinity of the dispenser or island.

DEF is non-flammable. Therefore, explosion and fire safety warnings do not apply to DEF lines.

Important Safety Information

No Open Fire



Open flames from matches, lighters, welding torches or other sources can ignite fuels and their vapors.

No Sparks - No Smoking



Sparks from starting vehicles, starting or using power tools, burning cigarettes, cigars or pipes can also ignite fuels and their vapors. Static electricity, including an electrostatic charge on your body, can cause a spark sufficient to ignite fuel vapors. Every time you get out of a vehicle, touch the metal of your vehicle, to discharge any electrostatic charge before you approach the dispenser island.

Working Alone

It is highly recommended that someone who is capable of rendering first aid be present during servicing. Familiarize yourself with Cardiopulmonary Resuscitation (CPR) methods, if you work with or around high voltages. This information is available from the American Red Cross. Always advise the station personnel about where you will be working, and caution them not to activate power while you are working on the equipment. Use the OSHA Lockout/Tagout procedures. If you are not familiar with this requirement, refer to this information in the service manual and OSHA documentation.

Working With Electricity Safely

Ensure that you use safe and established practices in working with electrical devices. Poorly wired devices may cause a fire, explosion or electrical shock. Ensure that grounding connections are properly made. Take care that sealing devices and compounds are in place. Ensure that you do not pinch wires when replacing covers. Follow OSHA Lockout/Tagout requirements. Station employees and service contractors need to understand and comply with this program completely to ensure safety while the equipment is down.

Hazardous Materials

Some materials present inside electronic enclosures may present a health hazard if not handled correctly. Ensure that you clean hands after handling equipment. Do not place any equipment in the mouth

WARNING

In the event of inclement weather, including snow, ice, or flooding that makes driving conditions dangerous, please avoid servicing units. Always use available door stops to secure upper doors against unwanted/unexpected movement, especially during high winds. If necessary, reschedule service to avoid damage to the equipment. Weather may change unexpectedly; be aware of local weather conditions. During service, if conditions develop making service unsafe, close the unit(s) and proceed to a safe location.

WARNING

The pump/dispenser contains a chemical known to the State of California to cause cancer.

WARNING

The pump/dispenser contains a chemical known to the State of California to cause birth defects or other reproductive harm.



Gilbarco Veeder-Root encourages the recycling of our products. Some products contain electronics, batteries, or other materials that may require special management practices depending on your location. Please refer to your local, state, or country regulations for these requirements.

In an Emergency

Inform Emergency Personnel

Compile the following information and inform emergency personnel:

- Location of accident (for example, address, front/back of building, and so on)
- Nature of accident (for example, possible heart attack, run over by car, burns, and so on)
- Age of victim (for example, baby, teenager, middle-age, elderly)
- Whether or not victim has received first aid (for example, stopped bleeding by pressure, and so on)
- Whether or not a victim has vomited (for example, if swallowed or inhaled something, and so on)

WARNING



Gasoline/DEF ingested may cause unconsciousness and burns to internal organs. Do not induce vomiting. Keep airway open. Oxygen may be needed at scene. Seek medical advice immediately.

WARNING

DEF generates ammonia gas at higher temperatures. When opening enclosed panels, allow the unit to air out to avoid breathing vapors. If respiratory difficulties develop, move victim away from source of exposure and into fresh air. If symptoms persist, seek medical attention.

WARNING



Gasoline inhaled may cause unconsciousness and burns to lips, mouth and lungs. Keep airway open. Seek medical advice immediately.

WARNING



Gasoline/DEF spilled in eyes may cause burns to eye tissue. Irrigate eyes with water for approximately 15 minutes. Seek medical advice immediately.

WARNING



Gasoline/DEF spilled on skin may cause burns. Wash area thoroughly with clear water. Seek medical advice immediately.

WARNING





DEF is mildly corrosive. Avoid contact with eyes, skin, and clothing. Ensure that eyewash stations and safety showers are close to the work location. Seek medical advice/recommended treatment if DEF spills into eyes.

IMPORTANT: Oxygen may be needed at scene if gasoline has been ingested or inhaled. Seek medical advice immediately.

Lockout/Tagout

Lockout/Tagout covers servicing and maintenance of machines and equipment in which the unexpected energization or start-up of the machine(s) or equipment or release of stored energy could cause injury to employees or personnel. Lockout/Tagout applies to all mechanical, hydraulic, chemical, or other energy, but does not cover electrical hazards. Subpart S of 29 CFR Part 1910 - Electrical Hazards, 29 CFR Part 1910.333 contains specific Lockout/Tagout provision for electrical hazards.

Hazards and Actions

 WARNING	
	Spilled fuels, accidents involving pumps/dispensers, or uncontrolled fuel flow create a serious hazard.
	Fire or explosion may result, causing serious injury or death.
	Follow established emergency procedures. DEF is non-flammable. However, it can create a slip hazard. Clean up spills promptly.

The following actions are recommended regarding these hazards:

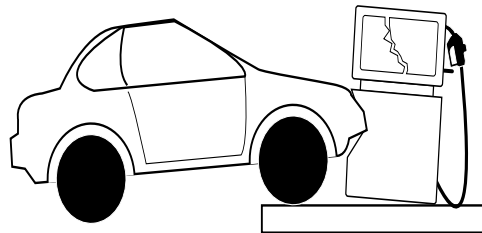

Collision of a Vehicle with Unit



Fire at Island

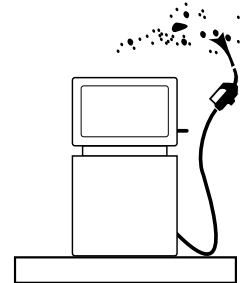

Fuel Spill

- Do not go near a fuel spill or allow anyone else in the area.
- Use station EMERGENCY CUTOFF immediately. Turn off all system circuit breakers to the island(s).
- Do not use console E-STOP, ALL STOP, and PUMP STOP to shut off power. These keys do not remove AC power and do not always stop product flow.
- Take precautions to avoid igniting fuel. Do not allow starting of vehicles in the area. Do not allow open flames, smoking or power tools in the area.
- Do not expose yourself to hazardous conditions such as fire, spilled fuel or exposed wiring.
- Call emergency numbers.

This page is intentionally left blank.

3 – Hazardous Locations

Classifying Hazardous Locations

Any activity (such as smoking or drilling) that can cause an explosion must be done well outside the vapor area.

Figure 3-1 is based on NFPA 30A and NFPA 70.

Figure 3-1: Hazardous Locations Diagram

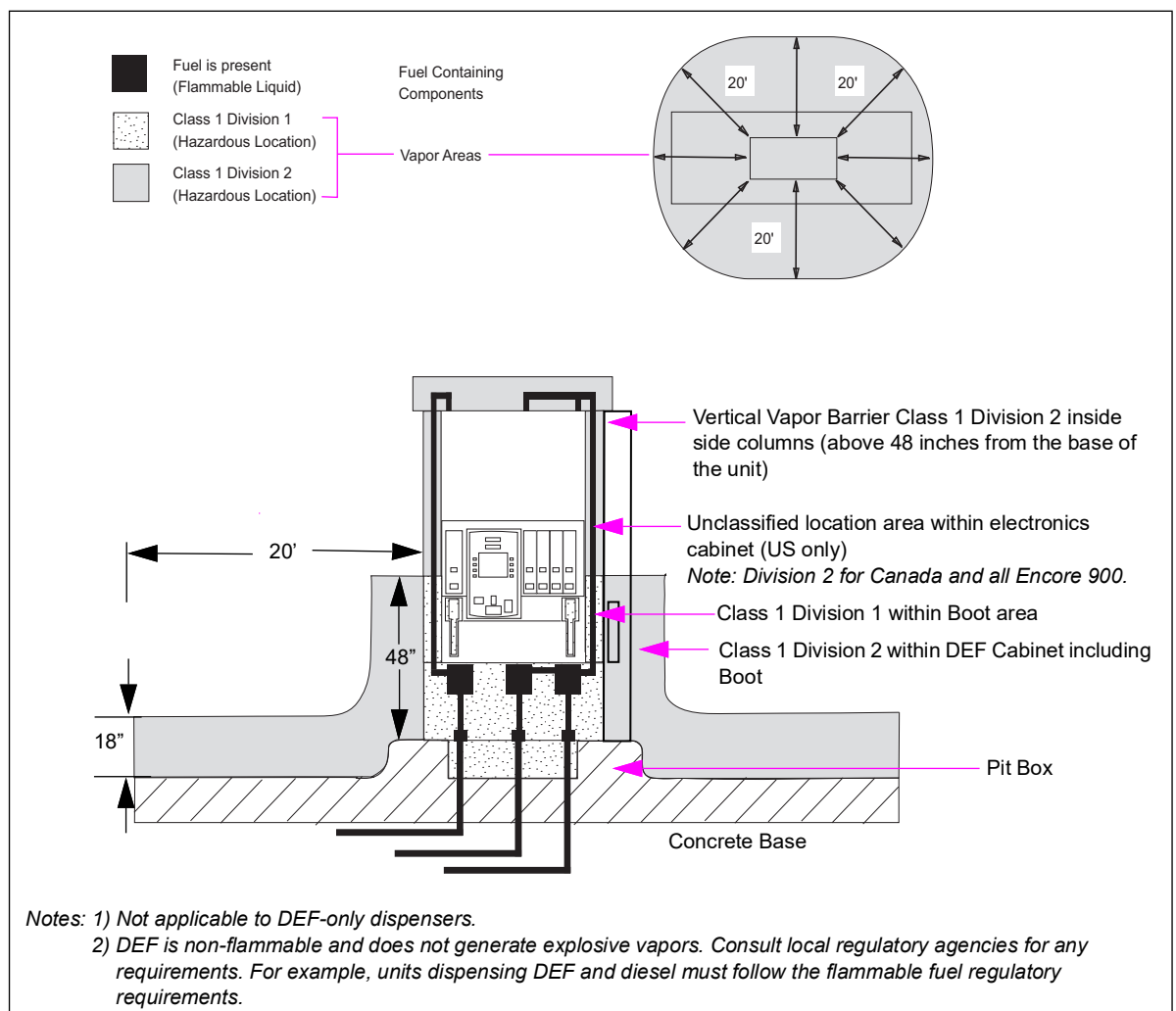

⚠ WARNING

NFPA 70 section 514 table 3 defines the area under the dispenser as a class 1 division 1 hazardous location. The DEF inlet must be installed as shown in [Figure 5-2](#) on [page 5-1](#) and [Figure 6-12](#) on [page 6-14](#) of the DEF module. The DEF inlet cannot be installed from a common pit box under the DEF cabinet onto the DEF cabinet.

Important Considerations for DEF Dispensers

CAUTION

Applicable during installation and operation of the dispenser. DEF freezes at about 11 °F (-11.5 °C). Power to the dispenser and heater must always remain ON in cold weather. If power is lost and the temperature drops below this point, the system must be inspected for freeze damage before restart. For sites that experience occasional power losses or for sites that are located in very cold climates, it is recommended that a backup power generator be used to maintain constant power to the dispenser. Do not use any additives to lower the freezing point of DEF. Additives of any type must not be used in DEF.

Prolonged storage at temperatures above 77 °F (25 °C) can impair the quality of DEF and reduce its shelf life.

CAUTION

DEF is mildly corrosive. It can corrode components that are made from incompatible material(s) and reduce their integrity. The use of incompatible material(s) may lead to leaks and spills, and can contaminate and degrade the DEF. When dispensing DEF, verify with the manufacturer if the material of all plumbing components are compatible with the DEF being dispensed.

CAUTION

Do not use prover cans meant for engine fuel with DEF or vice versa. Use stainless steel prover cans for DEF. DEF and engine fuel must not be mixed with each other or be contaminated by each other. Otherwise, damage to a vehicle's engine or pollution control devices could occur. DEF crystallizes as its water base evaporates. Pouring out liquid will not guarantee that no corrosive DEF remains in the prover can. DEF must not be contaminated with diesel fuel, contaminants, or other fluids or materials. Such contamination can cause serious damage to vehicle catalytic converters.

- Conventional fluid handling precautions are also applicable to DEF.
- Avoid contact with eyes, skin, and clothing. Ensure that eyewash stations and safety showers are close to the work location.
- DEF is mildly corrosive and non-flammable.
- Clean the DEF spill with water and dry the area with clean rags, especially areas that contain metallic parts. Spilt DEF can be slippery and will corrode certain types of metallic parts. Wear eye protection and rubber gloves during any cleanup activity.
- DEF is heavier than gasoline. Exercise care to avoid injury when handling or transporting DEF containers or DEF prover.

4 – Preliminary Installation Information

Replacing the Advantage Series Units with Encore Units

If you are replacing The Advantage Series unit(s) with Encore units, read [“Installation Differences when Replacing The Advantage Series”](#) on [page 10-2](#) before you begin.

Required Equipment and Materials

Following items are required to properly install the equipment:

- Anchor bolts
- U-bolts for fastening piping to braces
- Sealant that is UL-approved for use with fuels being encountered
- Pit box cover plates. Use when required to adapt the unit to pre-existing pit boxes
- Lifting device (crane, backhoe, forklift, and so on) to move and lift the pump/dispenser
- Nylon slings (with a safety lift factor of 5) and screw-pin anchor shackles to lift high hose pump/dispenser (refer to [“Encore Shipping Weight and Model Codes: N-X-X”](#) on [page 1-5](#))
- Breakaways, hoses, nozzles, and swivels
- Barricades
- Potting compound and fiber dam material to allow potting of the conduit in accordance with class I, division II locations as specified in the National Electrical Code (NEC)
- Any kits required for upgrading the unit to the customer’s requirements, such as hose retrievers, and so on

Dispensing Gasoline/Ethanol Blends

The blending option provided on 3+1+1 or 3-2 dispensers is intended. Ensure that when installing these units that the high alcohol product goes through the meter and plumbing designed to handle E85 or similar.

IMPORTANT INFORMATION

Standard gasoline or gasohol (E10 maximum) must not be dispensed through the same hose as that used for dispensing higher ethanol blend fuels (E11 to E85).

Alcohol used in some gasoline can damage small engine fueling systems. Typically, fuel sales for those engines are very small so the contamination in using an E85 product and then a straight gasoline product can result in a high percentage of alcohol in the fuel that may damage the small engine fueling system.

Important Consideration for Field Electrical Conduits Placement

To avoid field electrical conduits interfering dispenser units upon installation, electrical conduits outside the pit box should be mounted at proper location (see [Figure 4-1](#)) or refer M01432 Foundation Layout - Encore.

Figure 4-1: Field Electrical Conduits Placement

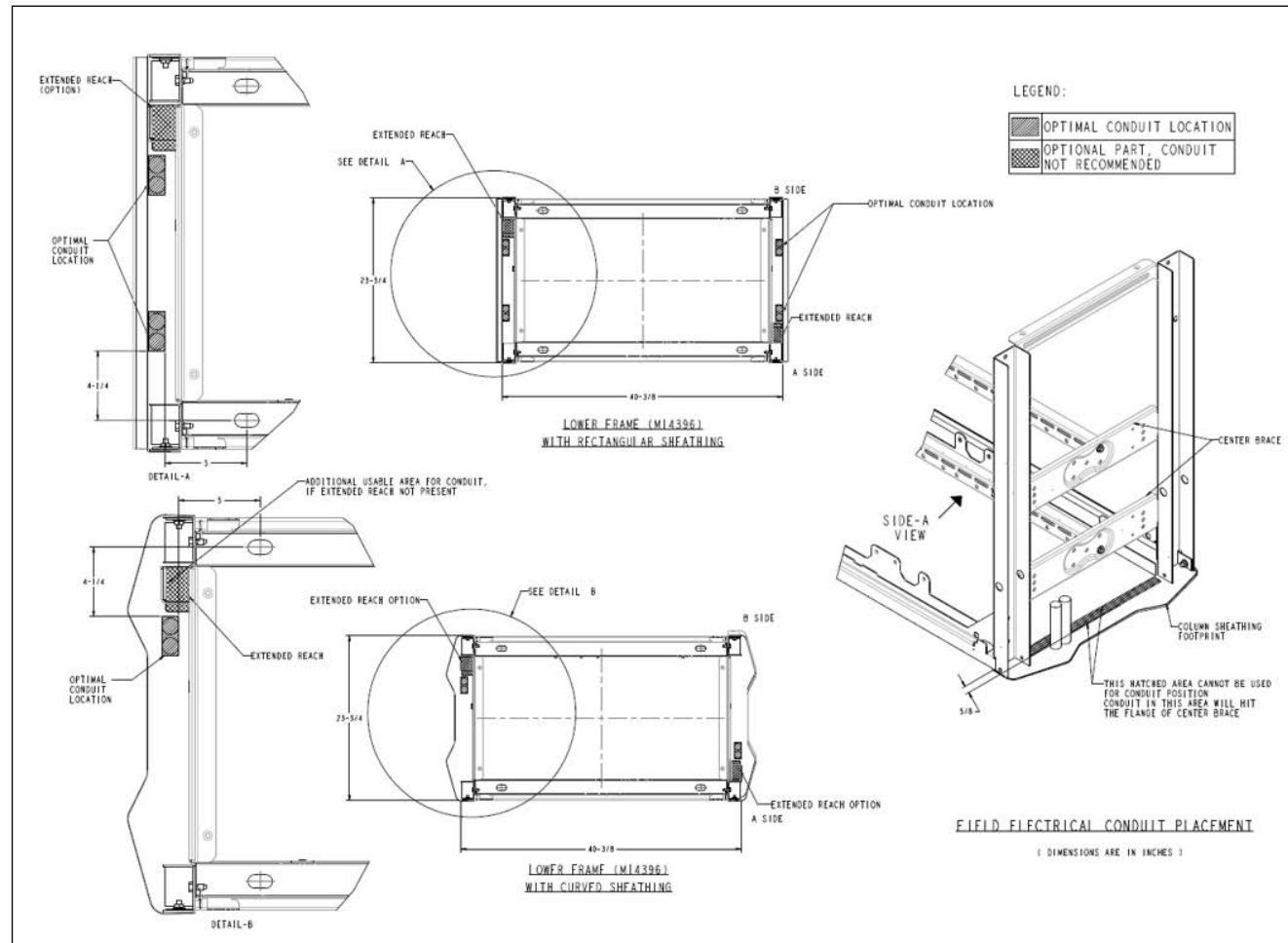

Use Conduit Template (M13952K001) to mount the electrical conduits outside the pit box. For more information, refer to *MDE-5153 Using Conduit Template (M13952K001) to Mount the Electrical Conduits*.

Important Consideration for Sizing STPs

To avoid cross contamination between the two tanks while dispensing gasoline/ethanol blends, do not oversize one STP over the other such that the line pressure of the stronger STP overpowers the other. This can result in cross flow from one tank to the other.

Important Requirements for E25/E40 and E85 Units

Only use equipment approved for fuel type, such as E25/E40 and E85.

CAUTION

Using Teflon tape where aluminum castings are involved could result in damage to the parts or contamination of Teflon tape shreds.

Read NFPA 30A and NFPA 70

WARNING

Where fuels are involved, you are working in a dangerous environment of gasoline, gasoline vapor, and electricity.

Failure to install this equipment in accordance with NFPA 30A and NFPA 70 could result in severe injury or death.

Where DEF only is involved you are working in a dangerous environment of electricity.

Read, understand, and follow NFPA 30A and NFPA 70.

Before installing the equipment, read, understand, and follow:

- The NEC (NFPA 70).
- The automotive and marine service code (NFPA 30A).
- Any national, state, and local codes that may apply.

Failure to install the equipment in accordance with NFPA 30A and NFPA 70 may adversely affect the safe use and operation of the system.

Accurate, sound installations reduce service calls. Experienced, licensed contractors must perform the installation and follow accurate and safe installation techniques. Careful installation can eliminate potential problems.

The equipment manufacturer must provide instructions for other equipment, such as STPs, shear valves, and underground tanks. Gilbarco does not provide complete installation instructions for other manufacturer's equipment.

Important Considerations When Changing Fuel Types

WARNING

Certain special alternative fuels, such as E25/E40 and E85, and additives can degrade pump/dispenser performance or integrity if the dispensers are not designed for use with such fuels. Additionally, converting to certain standard fuels (gasoline, diesel, kerosene, and so on) from alternative fuels, such as those with ethanol (E25/E40 and E85), methanol, or biodiesel, or from alternative fuels to standard fuels, can degrade dispenser performance or integrity. Similar effects can also occur when converting units to different standard fuel types. **As per UL 87A requirements, units dispensing E25/E40 and E85 fuel must not be used to dispense any other type of fuel such as gasoline.**

Leaks and potential environmental hazards can result or components may fail prematurely.

To avoid these issues, follow the guidelines in this section.

Following guidelines must be followed when changing fuel types for a pump/dispenser or using alternative fuels or fluids:

- Verify with your Gilbarco ASC or distributor if the fuel which you will be using is compatible with the pumps/dispensers to be dispensing the fuel.
- For flexible fuel dispensers, do not use standard hydraulic parts used in other Gilbarco pumps/dispensers for service parts in these units. Standard dispenser parts may not be compatible with fluids.
- Biodiesel fuels must be of American Society for Testing and Materials (ASTM) standards for biodiesel fuels. Mixes of diesel with cooking oils, other plant or animal derived oils, and so on, are not considered biodiesel. Use of such mixes may void warranty on the hydraulic components of the unit.
- Review the latest copy of the unit's warranty statement regarding the use of fuel.
- Certain fuels (especially fuels enhanced with alcohol) when first used in tanks previously containing a different fuel may clean out the tanks and force a large amount of contaminant into the dispenser. Other than abnormally clogging filters, this large quantity of contaminant may damage certain dispenser components. Do not run units without filters at such times. It is normally required that tanks and lines be cleaned of all water, sediment, and contaminant before such conversions to minimize potential pump/dispenser downtime or damage. Damage to hydraulic components from contamination when not using filters is not covered by Warranty. Consult your ASC or Gilbarco Distributor for recommendations.
- Do not use any equipment that was formerly used to store or dispense any other fuel or liquid with DEF. Dispensers designed for use with DEF must only be used with DEF.
- Do not use prover cans meant for engine fuel with DEF or vice versa.
- Although conversions from one fuel to an equivalent fuel (say from another supplier) generally do not create issues, it is recommended that after making any fuel type conversions (including those to alternative fuels, such as E25/E40 and E85, or back), all units be visually inspected for leaks two days, one week, and one month after fuel conversion. Have your ASC repair any leaks found. This must also be performed for standard fuels when significant new additives are incorporated.

IMPORTANT INFORMATION

The above guideline does not apply to flexible fuel model dispensers.

- Whenever non-equivalent fuel conversions are performed, it is recommended that all units be checked for calibration within one month of fuel conversion.
- Some non-equivalent fuel conversions will necessitate the requirement to change the pump/dispenser filter type previously used. Consult your ASC or Gilbarco distributor for any changes required.
- In Flexible fuel dispensers, Gilbarco recommends the use of 10 micron filters for gasoline-based flexible fuels. Although the use of finer filtration is allowable, filters will tend to clog prematurely, causing excessive filter maintenance cost.
- Use only meters and registration devices for DEF that have a National Type Evaluation Program (NTEP) Certificate of Compliance issued by the National Conference on Weights and Measures (NCWM).

- Non-metallic piping and components used in aboveground DEF service must have high melting points and adequate strength and durability. Some plastic compounds that are suitable for DEF may not be compatible with petroleum products. They must be avoided at locations where they can come in contact with petroleum from a routine operation or a spill.
- An anti-siphon valve must be installed on aboveground storage tanks where the DEF level can be at a higher elevation than the supply piping or the dispenser. The valve will prevent a potential leak in the piping from creating a siphon that can cause a product release.

Installation Considerations for Units with Ecometers

Following considerations are in addition to those recommended for standard dispensers without Ecometers:

- Ecometers with proper air purging will not generally vary from initial calibration settings. Therefore, ensure that you accurately set the initial settings. It is not required to allow a break in the period before finalizing calibration.
- Although initially set at the factory, meter calibration must still be verified/performed.

For Encore units with Ecometers, the following recommendations are absolute requirements. Failure to follow these requirements will be considered as abuse and can result in premature meter failure. Such damage will not be covered by warranty.

- You must always use the Gasoline Filter (M008007B010) or Diesel Filter (M08007B030) manufactured by PetroClear® filter in the units. Other filters may not filter the fuel/fluid properly under certain operating conditions, and can affect the durability of the Ecometer. Use of unapproved filters may void the warranty on the Ecometer.
- At no time during installation must the unit be run without a filter, with only a strainer, or with a different filter type.

Note: There are no exceptions to this rule.

- You must never over-speed the meter by attempting to purge air through it at a high flow rate. You must follow the instructions for all meters as found in this manual.
- To ensure warranty coverage, dirty/contaminated fuel tanks must be cleaned before the installation of Ecometer dispensers. If stations experience multiple failures of meters from contaminated fuel, the warranty of meters will be voided.

Note: If filters have been plugging or failing prematurely, then the most likely cause is dirty fuel.

Software Considerations for Units with Ecometers

Units with Ecometers currently require V1.8.20 software or later. Versions earlier than V1.8.09 will not work with Ecometers.

Installation Checklists

Checklists for installation, startup, and commissioning are provided in the documentation package supplied with each unit. The installer must complete the checklist for each unit installed, and insert it inside the unit's electronics cabinet. Ensure that the checklists are placed in an area away from electrical devices and wiring.

The installation checklist requires certain critical inspections by the installer to verify if the installation was performed properly. Properly completed forms will help verify the safe installation for certain critical areas and is required to obtain warranty coverage, to help ensure proper operation of the equipment, and provide some liability protection for the installer, manufacturer, and customers. Instructions are included on the forms. Not all requirements found in this manual are included in *MDE-4226 Encore/Eclipse Installation Checklist (Form A)* [or in *MDE-4897 Installation Checklist for Diesel Exhaust Fluid (DEF) Units (Form A)*], making it important for the installer to read, understand, and follow all recommendations within this manual as well to ensure safe and proper operation.

Preparing for Installation

To prepare for the installation, proceed as follows:

- 1 Read all instructions before you begin. It may be helpful to have a copy of *MDE-4226 Encore/Eclipse Installation Checklist (Form A)* [or in *MDE-4897 Installation Checklist for Diesel Exhaust Fluid (DEF) Units (Form A)*] in hand during the installation.

- 2 Follow all safety precautions:



- Barricade the area.
 - Do not allow vehicles in the work area.
 - Do not smoke or allow open flames in the work area.
 - Do not use power tools in the work area.
 - Do not allow unauthorized people into the work area.
 - Wear eye protection during the installation.
 - Ensure that there is no power supplied to the units until required, as per later installation steps.
- 3 Use circuit breakers to turn off all power to pumps/dispensers and STPs. Multiple disconnects may be required.
 - 4 Check the following for proper installation, as recommended in *MDE-3802 Encore and Eclipse Site Preparation Manual* and by other manufacturers:
 - Emergency power cut off switch
 - Circuit breakers
 - STP control relay boxes - dispensers only (refer to Note 3)
 - Isolation relays - dispensers only (refer to Note 3)
 - Conduit and wiring (refer to Note 1)
 - Grounding

- Shear valves - dispensers only (refer to Notes 2 and 4)
- Piping and fittings
- Fuel storage tanks
- Pressure regulating valves (aboveground tanks only)
- STP - dispensers only
- Tank and/or line leak detectors
- Pit boxes
- Components must be compatible with the fluid being dispensed. Consult the manufacturer for information.

Notes: 1) If you are replacing an existing unit, the installer may connect and extend the existing field wires to the electronics cabinet using an explosion proof Junction Box (J-box). For details, refer to "Before Mounting Unit on Fuel Island" on page 4-9.

2) A shear valve (as per NFPA 30A) is a safety device required for every product line at each dispenser. For installation instructions, refer to MDE-3802 Encore and Eclipse Site Preparation Manual. Shear valves may also be required for aboveground tank installations and other installations with pumps. Follow local and state requirements.

3) Refer to MDE-2755 STP Control and Dispenser Isolation Relay Box (PA0287).

4) Some locations require shear valves for vapor lines. Follow local and state regulation.

- 5 Inspect the pump/dispenser cartons and contents for shipping damage. Gilbarco does not cover shipping damage under its warranty policy. Notify the shipper of any damage.
- 6 Open the CIM door and remove any tie-wraps that are holding the pulsers in place.

CAUTION

Not removing the shipping tie-wraps may result in inaccurate calibration or failure of pulsers.

Note: Only some models are shipped with tie-wraps to secure pulsers.

- 7 Remove the lower panels (doors) of the pump/dispenser. For the procedure to remove the lower panels, refer to MDE-3804 Encore and Eclipse Start-up/Service Manual.
- 8 Ensure that the fuel grade for product lines matches the pump/dispenser brand panels and the foundation layout. Product lines from the island pit box must have labels.
- 9 Ensure that meters and valves handling E15 to E85 fuels are usable with that fluid. Some dispensers may be ordered where only certain hydraulic lines are designed for high alcohol usage.

Gaining Access to and from Encore Cabinet

Encore cabinets are designed to protect the equipment inside the unit from the elements. The doors and covers must be installed as directed. For more information, refer to owner/service manuals provided by the ASCs during commissioning.

On Encore 300/500 square bezel units containing special weather protection features, the top door must be opened first and then the bottom panel has to be removed. While closing, the bottom panel must be reinstalled and then the top door has to be closed. This will ensure weather proofing and protect the unit. For units that require further protective features, refer to *MDE-4473 Encore Dispenser Water Intrusion Prevention Kit*.

Encore S series units have features that prevent water intrusion into the dispenser's interior. However, the doors and covers must be opened or replaced in a specific order - the bottom panel first, which provides access, allowing the release of the security latch on the top door and opening of the door.

WARNING

In the event of inclement weather, including snow, ice, or flooding that makes driving conditions dangerous, please avoid servicing units. Always use available door stops to secure upper doors against unwanted/unexpected movement, especially during high winds. If necessary, reschedule service to avoid damage to the equipment. Weather may change unexpectedly; be aware of local weather conditions. During service, if conditions develop making service unsafe, close the unit(s) and proceed to a safe location.

Before Mounting Unit on Fuel Island

WARNING

DEF, flexible fuels such as biodiesel; high alcohol percentage fuels such as E25/E40 and E85, and so on, may be incompatible with certain plumbing materials and hydraulic components.

Use of incompatible materials or components with alternative fuels such as E25/E40 and E85, or DEF can result in leaks or unexpected failures of components resulting in fire or explosion or environmental damage. When installing components in E25/E40 and E85 units, refer to "[Important Requirements for E25/E40 and E85 Units](#)" on [page 4-3](#).

When dispensing alternative fuels such as E25/E40 and E85, or DEF, verify with the manufacturer if the material of all plumbing components are compatible with the fuels such as E25/E40 and E85, or DEF being dispensed.

Note: Before mounting the unit on the fuel island, read and understand this section completely. This information is essential to avoid installation errors.

Verifying and Determining Plumbing Requirements

Before placing a unit on an island, determine the correct location of piping for the unit involved and the proper orientation of the unit. A common installation error is to install the units backwards, which will require expensive modifications. This section contains information regarding plumbing requirements for various models of Encore series dispensers.

IMPORTANT INFORMATION

Do not make assumptions about configurations based on previous experience, hose positions, or layout of the unit that you are replacing, whether it is a Gilbarco unit or that of any other manufacturer.

Model grade mapping (inlet piping) for Encore units is different from The Advantage Series and MPD-3 series as well as other manufacturer's units. Incorrect matching of unit piping to supply lines can cause costly rework and time delays.

Encore Y and Z inlets are never used for blended products. Z is always a Straight/Unblended Product Inlet, +Z is always a Straight/Unblended +1 Product (with the exception of model NJ4, 3 + 2 dual blender, see [Figure 5-11](#) on [page 5-11](#)).

Typical 3-grade MPD configuration: W = Product 1, X = Product 2, and Y = Product 3. Product number does not signify the grade on MPD units, for example, Product 1 is not always Lo Grade, but is optionally Lo, Mid, or Hi.

W = Product 1 (on Blenders only, Product 1 is always a Lo Product).

The first grade/product is always right to left when facing side 1 for Encore units.

Adapting Pit Box

For installation using an existing pit box, some modifications may be required. Following list highlights the changes that may be required. For more information, refer to [“Installation Differences when Replacing The Advantage Series”](#) on [page 10-2](#). These installation considerations may also apply when you are replacing competitive units.

To adapt the plumbing/conduit to Encore stub up locations:

- Use care in sizing and routing flexible piping to avoid bends that restrict flow. This is especially critical for pumps which may have serious issues with flow or noise if the flexible pipe cross section becomes significantly restrictive.
- Use flexible piping in the pit box for plumbing adaptation. If piping in the previous box is rigid, use the adaptability of the Encore hydraulic cabinet inlets and conduit entry points instead of making modifications to rigid plumbing and conduit in the pit box.
- When adapting plumbing in the dispenser cabinet, remember that the lower piping cross brace must be used to secure plumbing above the shear valve and that rigid piping must be used within the dispenser.
- Modify the pit box rain lip when required (for boxes designed for The Advantage Series wide frame units). Modifications will also typically be performed to the Encore base.

- When adapting an Encore unit to an existing pit box or one that is not specifically designed for the unit, the rain lip may require modification or removal. If the rain lip is removed, the entire base of the dispenser must be sealed to the island. Study the foundation layouts and the existing pit box to determine if modifications are required before mounting the unit on the island. For working in this area, refer to the following warning.

WARNING

Where fuels are involved, you are working in a potentially hazardous environment where fuels and their vapors may be present and could be ignited with sparks from grinding and cutting tools.

Always conduct work at the required safe distance away from a hazardous area and use the appropriate tools.

- For the DEF units, dispensers mounted on a pedestal will not be properly heated in the DEF cabinet. An insulated adaptive cover must be used to cover and insulate the raised DEF cabinet.

Units with Ground Fault Interrupt (GFI)

GFI breakers are required for DEF only units installed on and with a skid tank platform because of no underground piping, AC power in potentially wet area, and a potential for earth ground to become broken if skid tank moves.

A GFI consists of a sensor that detects changes in the current to the load, by comparing the current flowing **to** the load and the current flowing **from** the load. A drop-off in the current equivalent to about 5 milliamperes, turns off all power by tripping a relay within the GFI within a few hundredths of a second.

When powering a dispenser with a GFI, the return neutral of any device to which the dispenser supplies power must be the same neutral as that of the dispenser. For example, the STP control relay.

Installing Conduit at Pump/Dispenser

Options exist for installing the conduit up to the units:

- Use existing conduit commonly through the pit box.
- Conduit not penetrating the pit box but entering the pump dispenser through the side column(s) of the unit.

The first method is commonly found with existing applications. The second is recommended for new ground and up installations to reduce installation cost.

For Installations in Canada

For installations in Canada the applicable code is CSA C22.1, The Canadian Electric Code (CEC). Other codes may apply and should be verified with the authority having jurisdiction.

IMPORTANT INFORMATION

(Applies to the province of British Columbia only)

The **British Columbia Safety Authority** issued a decision stating that data cables and AC cables in the same conduit do not comply with the requirements for communication wiring as specified in CEC rule 60. In British Columbia, installing communication circuits, such as data cables and AC cables, in the same conduit as AC circuits is contrary to the CEC rule 60.

- New installations must have separate conduit for data/communication cables and power cables in the following circumstances (wiring for two-wire, data, communications, intercom, video, Ethernet, Gilbarco Long Range Ethernet (GLRE), must be in a separate conduit from the dispensers power and light conduit):
 - All new installations of fuel dispensers or other electrical equipment, whether or not the raceways are exposed and made readily accessible as part of the installation process; or
 - In any event if the raceways are exposed and made readily accessible for any reason.
- Separate conduits are not required in respect of the repair, modification or replacement of one or more existing pieces of electrical equipment or components thereof unless the raceways are exposed and made readily accessible as part of the repair, modification or replacement.
 - “Components” include card readers in fuel dispensers
 - “Electrical equipment” includes a fuel dispenser and “replacement” means the substitution of one electrical component or piece of equipment with another having the same essential function and provided always that:
 - * Neither the electrical rating nor the characteristics of the equipment is altered; and
 - * The replacement components are of a type which do not invalidate the original certification mark.
- A raceway is exposed and made readily accessible if it can be removed or replaced without significant additional disturbance to the material enclosing or overlaying it, including without limitation excavation of soil, asphalt or any other material by mechanical means, provided that a raceway is not to be considered exposed and made readily accessible merely because one or both ends of the raceway become visible during the repair, modification or replacement of electrical equipment or components.

Installing Units with Conduit Entry in Side of Electronics Cabinet

Note: For more information, refer to MDE-4701 Side Conduit Entry Hardware Kit (M07838K001) Installation Guide for Encore Units.

Installation cost can commonly be reduced for new sites by installing the conduit to the dispenser through the side columns and then into the side(s) of the electronics cabinet. Side column conduit routing eliminates the requirement for the conduit to penetrate the pit box and costs and issues potentially related to that. Entry of the conduit into the side of the electronics cabinet simplifies the routing and forming of the conduit. Certain requirements exist to ensure that such installations are as per Gilbarco recommendations and will meet the required code.

For new installations, install the dispenser conduit such that it does not penetrate the pit box. For more information, refer to M01432 Foundation Layout - Encore.

Following guidelines must be followed when installing the unit:

- Special care must be taken when lowering the dispenser over the conduit to avoid damage to the conduit or any pulled wiring. Temporary removal of the side panel is recommended to aid in visualizing, and for later installation of an additional conduit segment. Preferably, the wiring must be pulled after the dispenser is placed over the conduit.
- Two options are possible for routing the wiring to the electronics cabinet:
 - From the column to the hydraulics cabinet, and then through the lower and upper air gap plates.
 - Through the column to the side of the electronics cabinet and then into the electronics cabinet using one or more of the knock out holes provided.

Figure 4-2: Conduit Potting (Through Side of Electronics Cabinet)

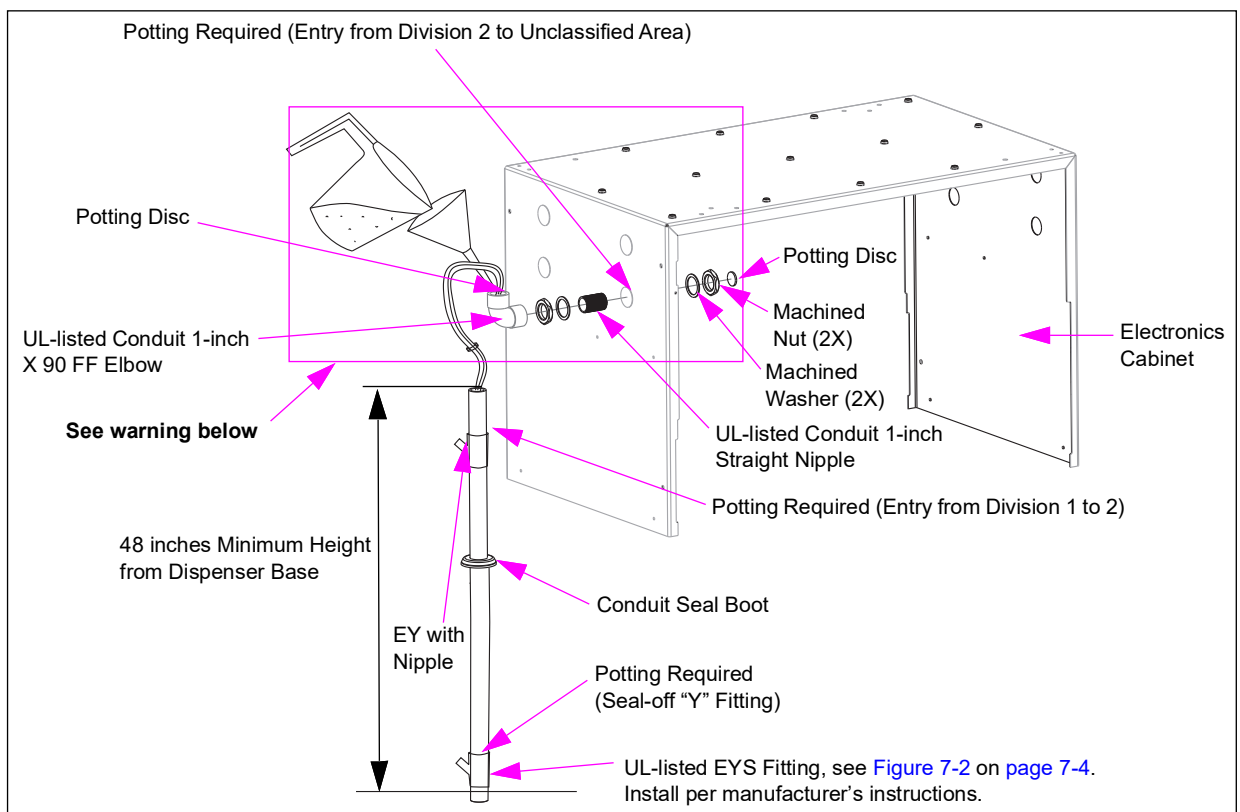

⚠ WARNING

Installation using this method requires Gilbarco Installation Kit (M07838K001). Failure to use the kit will result in damage or injury.

This page is intentionally left blank.

5 – Unit Configuration

Multi Product (MPD) Configuration

Dispenser (MPD) Configuration

For dispenser blenders, proceed to “[Dispenser Blender Configuration](#)” on page 5-10. For more information, refer to *M01432 Foundation Layout - Encore*.

Note: For units with the Ecometer option, pipe directly to the manifold. Practice care when installing piping directly to the aluminum manifold. It is strongly recommended that you attach the lower U-bolts to the installer-provided inlet pipe, at the cross bar, before wrenching the pipe tight. This will help prevent damage to the manifold threads or casting from incorrect threading or side loading of the pipe from wrench action during tightening. The U-bolts must be initially tightened to allow the pipe to be easily tightened but still remain aligned. After the pipe is installed, tighten all the U-bolts.

Figure 5-1: Encore Dispenser MPD Product Inlets

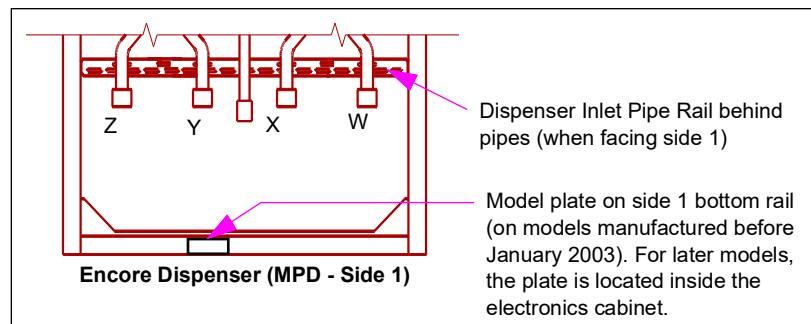
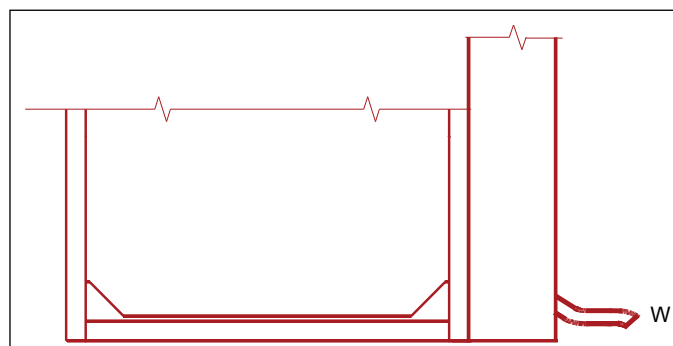

Figure 5-2: DEF Only Dispenser - Product Inlet



⚠ WARNING

To meet regulatory requirements, the DEF inlet must be installed from the side of the DEF module. Inlet cannot be installed from a pit box under the DEF cabinet.

Model #	MPD Model Description	Encore Inlets	Product Inlets (Typical)
NA0	1-grade 2-hose MPD Dispenser	W	W = Product 1
NA1	2-grade 4-hose MPD Dispenser	W, X	W = Product 1 X = Product 2
NG4	2-grade Single-hose MPD Dispenser		
NA2	3-grade 6-hose MPD Dispenser	W, X, Y	W = Product 1 X = Product 2 Y = Product 3
NG0	Single-hose MPD Dispenser 3-grade 2-hose		
NA3	MPD Dispenser 4-grade 8-hose	W, X, Y, Z	W = Product 1 X = Product 2 Y = Product 3 Z = Product 4
NA4	1-grade Single-hose DEF only Dispenser	W	W = DEF
NG1	Single-hose +1 MPD Dispenser, 3+1-grade, 4-hose	W, X, Y, +Z	W = Product 1 X = Product 2 Y = Product 3 +Z = Straight/Unblended Product

Note:

The information provided in the table is for two-sided units.

- Z is always a Straight/Unblended Product Inlet, +Z is always a Straight/Unblended +1 Product.
- Product number does not signify grade on MPD units, for example, Product 1 is not always Lo Grade, but is optionally Lo, Mid, or Hi.

Dispenser MPD Piping to Hose Fitting Configurations

Note: For multi-hose units, piping must align with graphics when facing side 1.

Figure 5-3: Encore Dispenser MPD Piping to Hose Fitting Layout

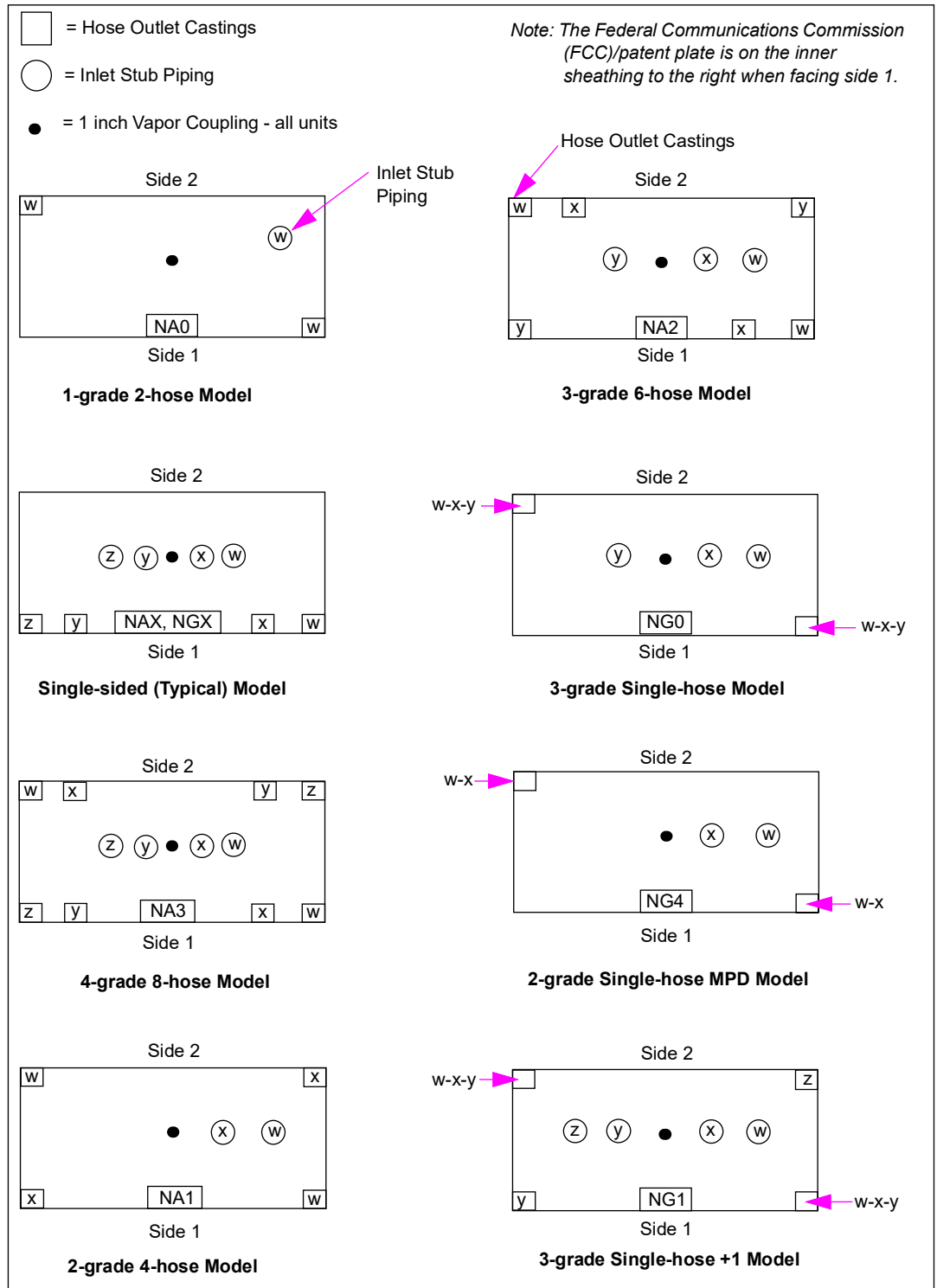
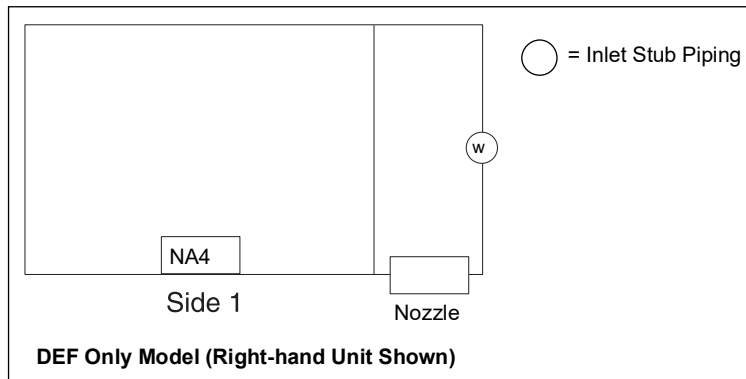

Figure 5-4: DEF Only Dispenser - Piping to Hose Fitting Configuration

Ultra-Hi Configuration

Dispenser Ultra-Hi Configuration

For MPD configuration, refer to [“Dispenser \(MPD\) Configuration”](#) on [page 5-1](#) and for dispenser blender configuration, refer to [“Dispenser Blender Configuration”](#) on [page 5-10](#).

Figure 5-5: Dispenser (Ultra-Hi) Product Inlets - Standard Installation

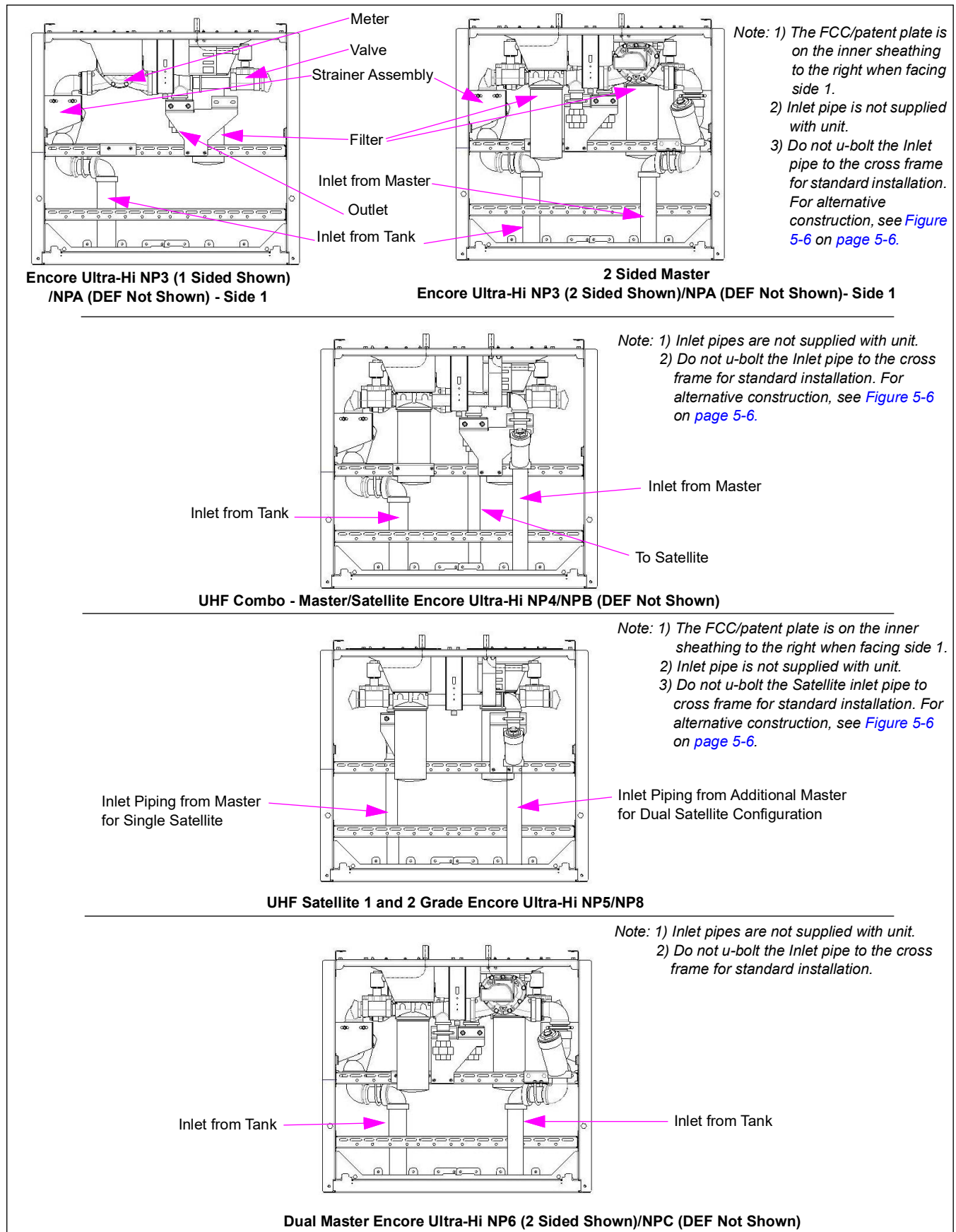
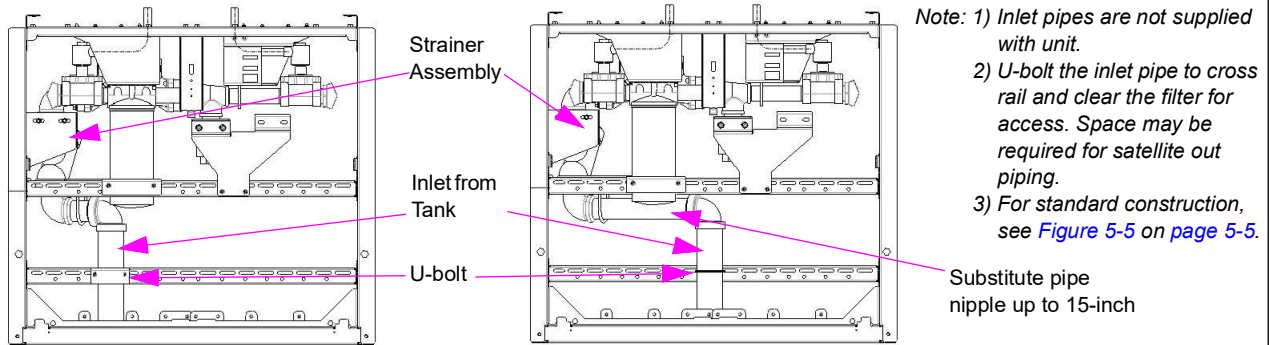
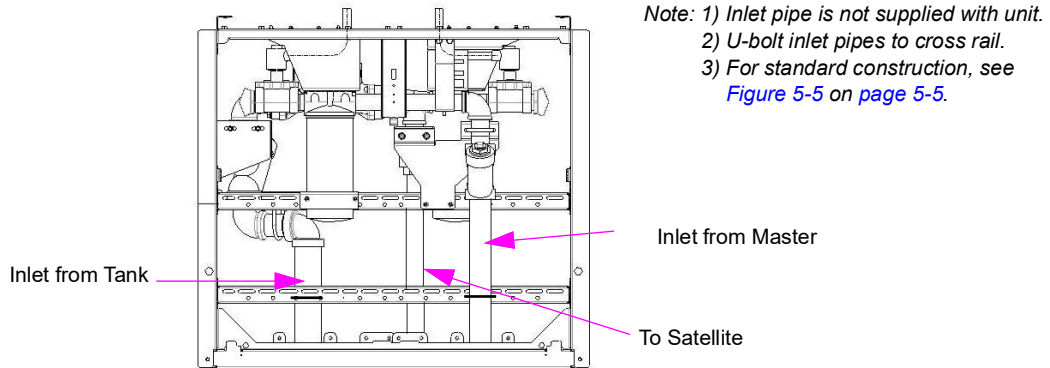

Figure 5-6: Dispenser (Ultra-Hi) Product Inlets - Alternate Installation



Alternate Install Single Master (2 Sided similar) Encore Ultra-Hi Alternate Install NP3 (1 Sided shown)/NPA (DEF Not Shown) - Side 1



Encore Ultra-Hi Alternate Install NP4/NPB (DEF Not Shown) - Side 1

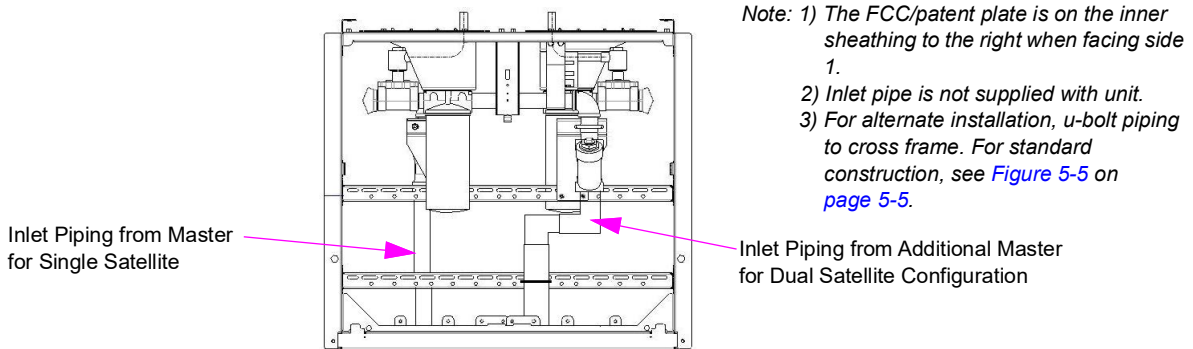

UHF Satellite Alternate Install 1 and 2 Grade Encore Ultra-Hi NP5/NP8

Dispenser Ultra-Hi Piping to Hose Fitting Configuration

Figure 5-7: Encore Dispenser Ultra-Hi Piping to Hose Fitting Layout

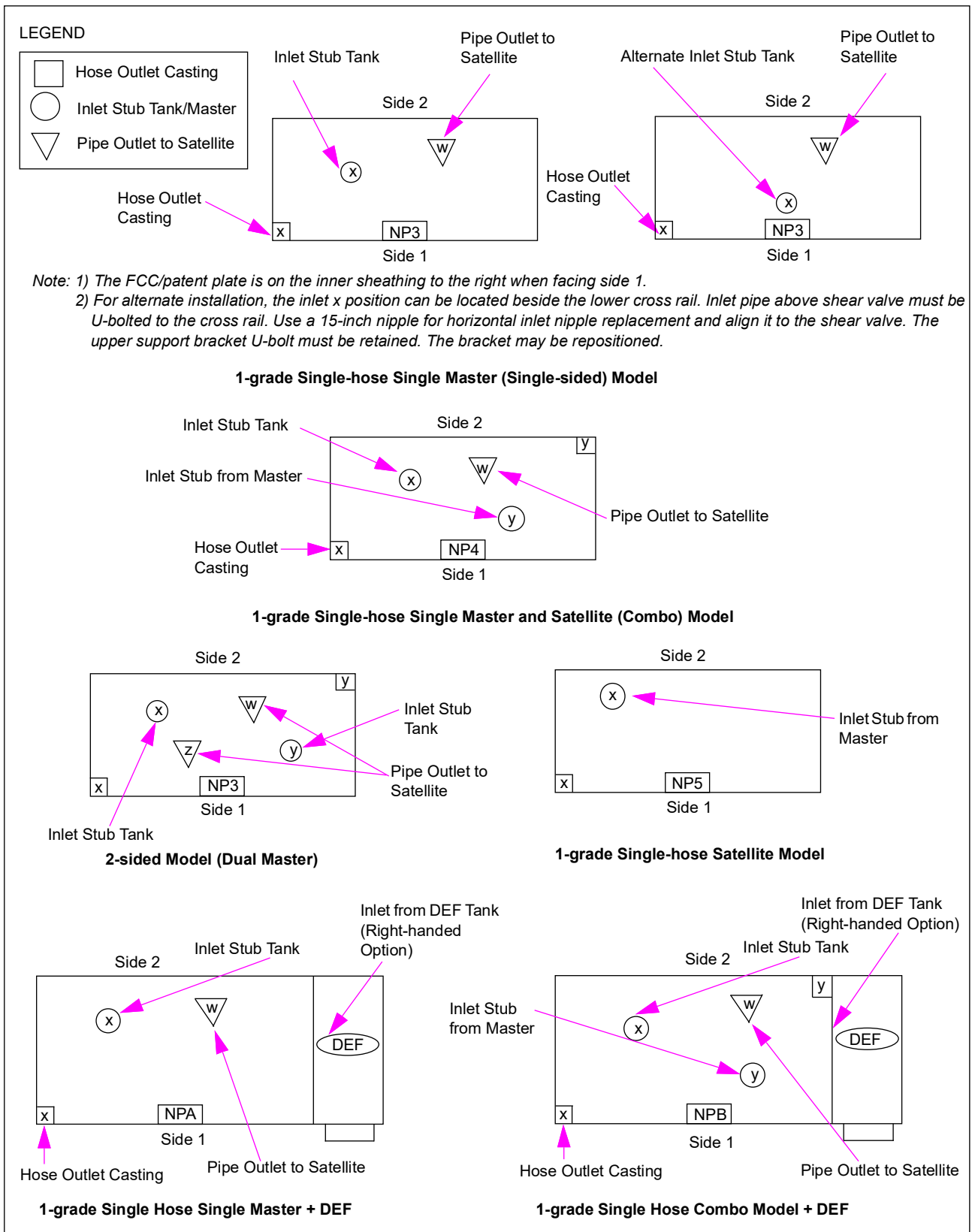

Pump (MPD) Configuration

For pump blender configuration, refer to “Dispenser Blender Piping to Hose Fitting Configuration” on page 5-16.

Figure 5-8: Encore Pump (MPD) Product Inlets and J-box

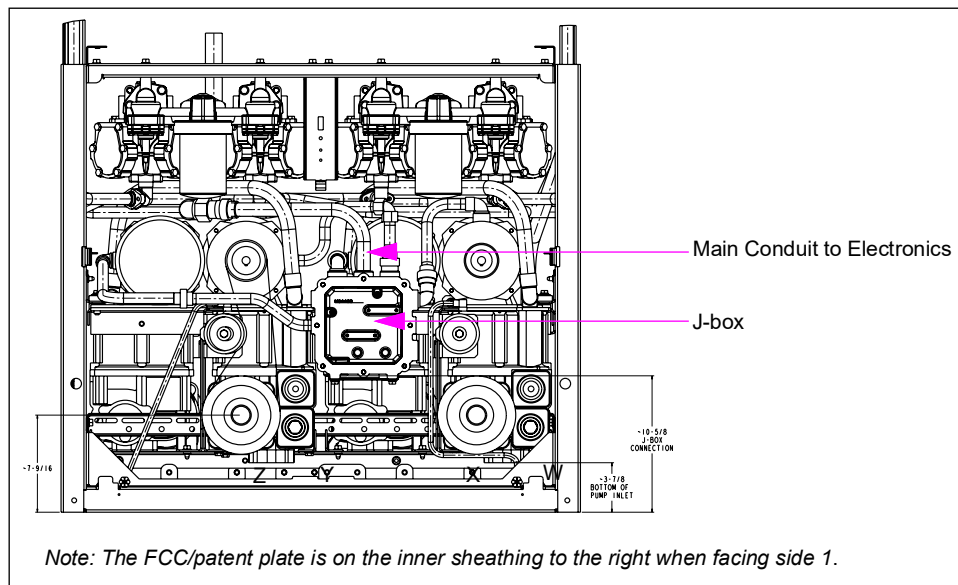

Model #	Multi Product Pump Model Description	Encore Inlets	Product Inlets (Typical)
NC0	1-grade 2-hose MPD Pump	W	W = Product 1
NC1	2-grade 4-hose MPD Pump	W, X	W = Product 1 X = Product 2
NG5	2-grade Single-hose MPD Pump		
NC2	3-grade 6-hose MPD Pump	W, X, Y	W = Product 1 X = Product 2 Y = Product 3
NG2	Single-hose MPD Pump 3-grade 2-hose		
NC3	MPD Pump 4-grade 8-hose	W, X, Y, Z	W = Product 1 X = Product 2 Y = Product 3 Z = Product 4
NG3	Single-hose +1 MPD Pump, 3+1-grade, 4-hose	W, X, Y, +Z	W = Product 1 X = Product 2 Y = Product 3 +Z = Straight/Unblended Product

Note:

The information provided in the table is for two-sided units.

- Z is always a Straight/Unblended Product Inlet, +Z is always a Straight/Unblended +1 Product.

- Product number does not signify grade on MPD units, for example, Product 1 is not always Lo Grade, but is optionally Lo, Mid, or Hi.

Pump (MPD) Piping to Hose Fitting Configuration

Note: For multi-hose units, piping must align with graphics when facing side 1.

Figure 5-9: Encore Pump Piping to Hose Fitting Layout

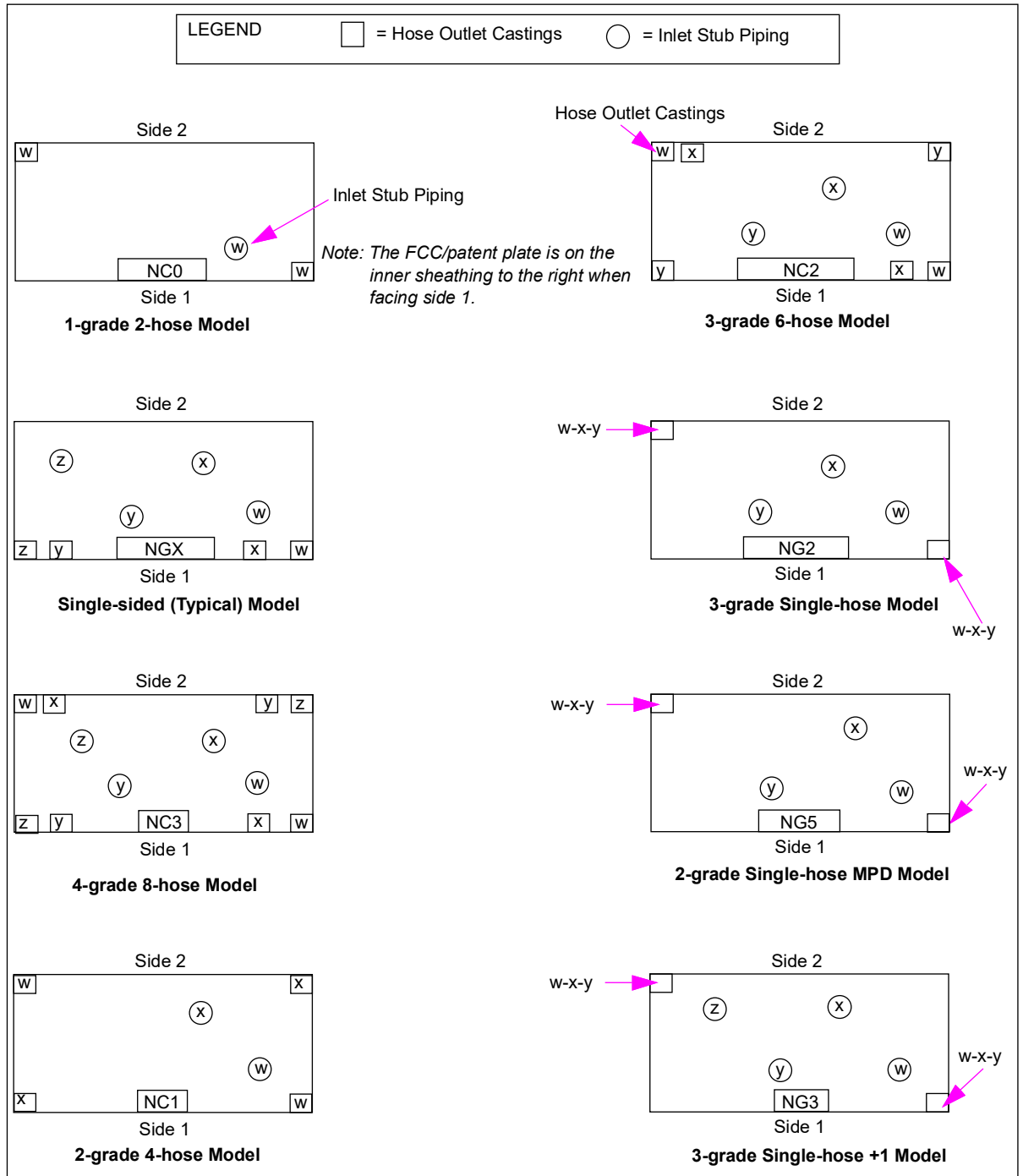

Blender Configuration

Dispenser Blender Configuration

For dispenser (MPD) blender configuration, refer to “[Dispenser \(MPD\) Configuration](#)” on [page 5-1](#).

Read and understand all information in “[Before Mounting Unit on Fuel Island](#)” on [page 4-9](#).

Note: For units with the Ecometer option, pipe directly to the manifold. Practice care when installing piping directly to the aluminum manifold. It is strongly recommended that you attach the lower U-bolts to the installer-provided inlet pipe, at the cross bar, before wrenching the pipe tight. This will help prevent damage to the manifold threads or casting from incorrect threading or side loading of the pipe from wrench action during tightening. The U-bolts must be initially tightened to allow the pipe to be easily tightened but still remain aligned. After the pipe is installed, tighten all the U-bolts.

Figure 5-10: Dispenser (MPD) Product Inlets

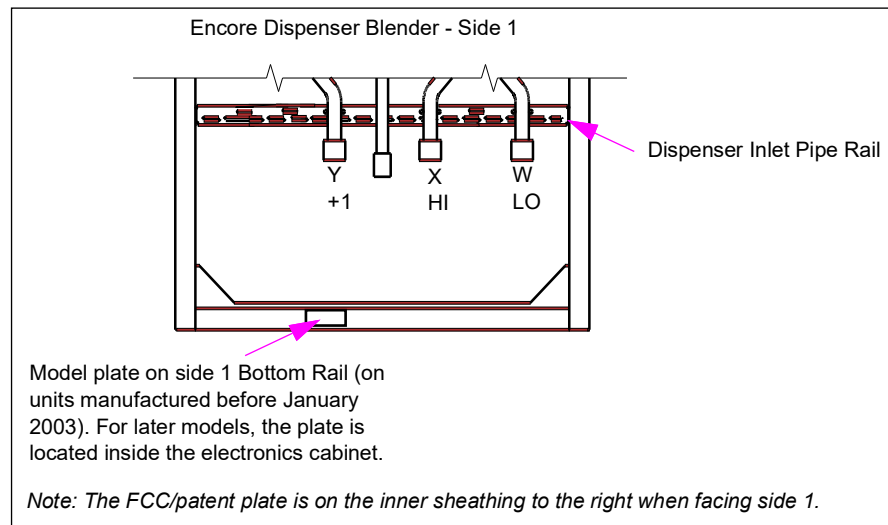

Model #	Blender Dispenser Model Description	Encore Inlets	Product Inlets (Typical)
NN1	Blender Dispenser 3+0		
NN2	Blender Dispenser 4+0	W, X	W = Lo Product X = Hi Product
NN3	Blender Dispenser 5+0		
NJ0	Multi-hose Blender Dispenser 3-grade 6-hose		
NL0	Blender Dispenser 2+1		
NL1	Blender Dispenser 3+1		W = Lo Product X = Hi Product
NL2	Blender Dispenser 4+1	W, X, Y	Y = +1 Straight/ Unblended Product
NL8	Blender Dispenser 5+1		
NJ2	Multi-hose Blender Dispenser 3+1-grade, 8-hose		

Notes:

- W = Product 1 (**On Blenders only Product 1 is always Lo Product**)
- X = Product 2
- Y = Straight/Unblended Product Inlet

Figure 5-11: Dispenser Blender Product Inlets (Model # NL3)

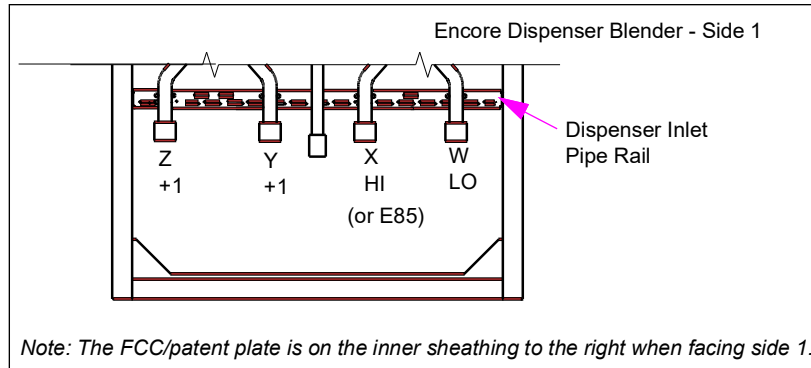

Model #	Blender Dispenser Model Description	Encore Inlets	Product Inlets (Typical)
NL3	Blender Dispenser 3 + 1 + 1	W, X, Y, Z	W = Lo Product X = Hi Prod or E85 <i>Note: Selectable Blender Side of Dispenser.</i> Y = + 1 Straight Z = + 1 Straight <i>Note: Straight Product Side of Dispenser.</i>

Notes:

- W = Product 1 (**On Blenders only Product 1 is always Lo Product**)
- X = Product 2 - If the selectable blender side of the dispenser is to include E85, inlet "X" will be for E85
- Y = Straight/Unblended Product Inlet
- Z = Straight/Unblended Product Inlet - If one straight product is to be E85, inlet "Z" will be for E85

Figure 5-12: Dispenser Blender Product Inlets (Model #NJ4)

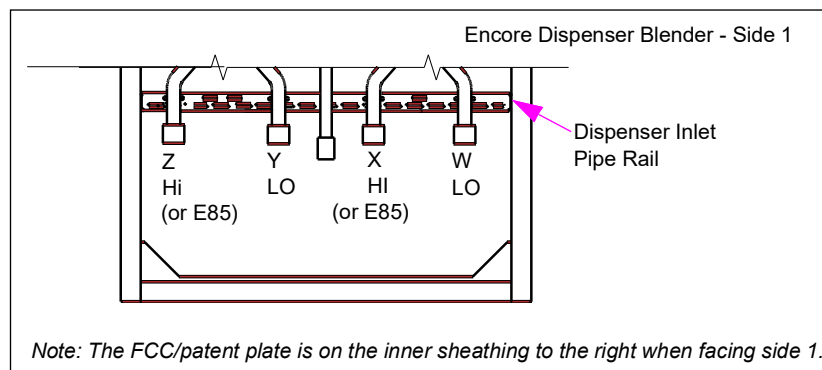

Model #	Blender Dispenser Model Description	Encore Inlets	Product Inlets (Typical)
NJ4	Blender Dispenser 3 + 2	W, X, Y, Z	W = Lo Product X = Hi Prod or E85 <i>Note: Selectable Blender Side of Dispenser</i> Y = Lo Product Z = Hi Prod or E85 <i>Note: Multi-hose Blender Side of Dispenser</i>

Model #	Blender Dispenser Model Description	Encore Inlets	Product Inlets (Typical)
---------	-------------------------------------	---------------	--------------------------

Notes:

- W = Product 1 (On Blenders only Product 1 is always Lo Product)
- X = Product 2 - If the selectable blender side of the dispenser is to include E85, inlet "X" will be for E85
- Y = Product 3
- Z = Product 4 - If the multi-hose blender side of the dispenser is to include E85, inlet "Z" will be for E85

Figure 5-13: Dispenser Blender Product Inlets (Model #NF1)

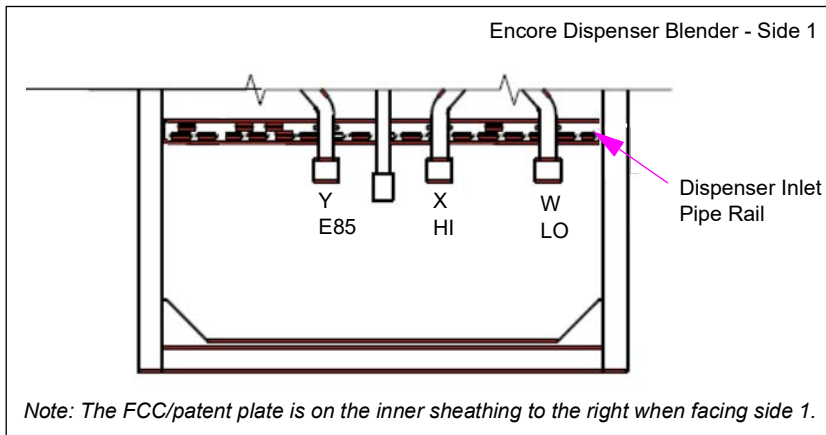

Model #	Blender Dispenser Model Description	Encore Inlets	Product Inlets (Typical)
NF1	Multi-hose Hybrid Blender 5 Grades	W, X, Y	W = Lo Product X = Hi Prod Y = E85

Notes:

- W = Product 1 is always the Lo (non flex) Product
- X = Product 2 is always the Hi (non flex) Product
- Y = is always the E85, plated hydraulic (considered high product for programming)

Blend Ratio - NF1, 5 Grade (3 Hose) Multi-hose Hybrid Blender

Figure 5-14: Blend Ratio (Model #NF1)

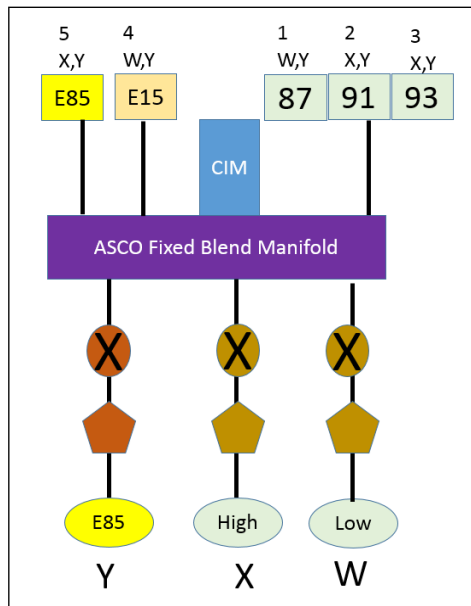

Note: The blend ratios are examples only. Blend ratios must be provided by the customer at the time of startup.

The following table provides example for blend ratio - NF1, 5 Grade (3 hose) multi-hose hybrid blender:

Button Grade	Delivered Product	Button Location	NF1 Example Inlet Product Percentages			Entry to Program for the Target Delivered Product
			W (Low Grade)	X (High Grade)	Y (E85)	
1	87 (Grade 1)	Middle Button	94%	0%	6%	94
2	91 (Grade 2)	Right Button to Grade 1	0%	100%	0%	100
3	93 (Grade 3)	Right Button to Grade 2	0%	91%	9%	91
4	E15 (Grade 4)	Left Button to Grade 1	88%	0%	12%	88
5	E85 (Grade 5)	Left Button to Grade 4	0%	0%	100%	0

Figure 5-15: Dispenser Blender Product Inlets (Model #NF2/NF4)

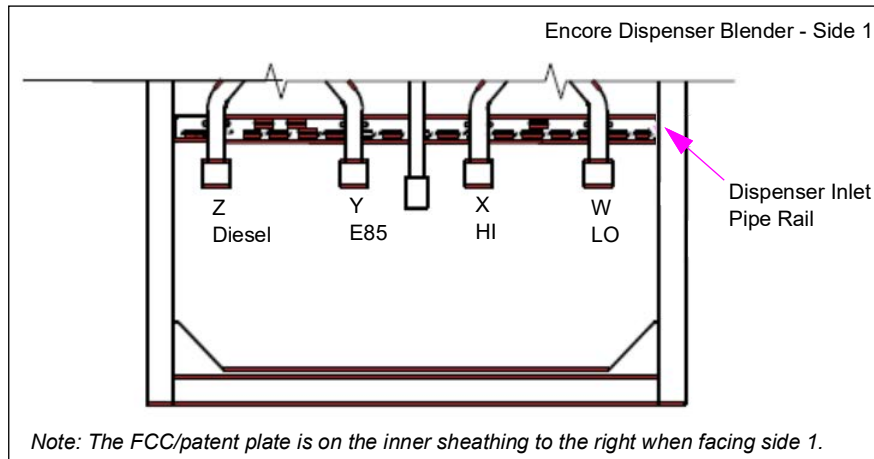

Model #	Blender Dispenser Model Description	Encore Inlets	Product Inlets (Typical)
NF2/NF4	Multi-hose Hybrid Blender 3-1+ 1, 3 Hose	W, X, Y, Z	W = Lo Product X = Hi Prod Y = E85 Z = + 1 Straight

Notes:

- W = Product 1 is always the Lo (non flex) Product
- X = Product 2 is always the Hi (non flex) Product
- Y = is always the E85, plated hydraulics (considered high product for programming)
- Z = is plus one, diesel product (or flex fuel + 1 grade)

Blend Ratio - NF2/NF4, 3-1+ 1, 3 Hose Multi-hose Hybrid Blender

Figure 5-16: Blend Ratio (Model #NF2)

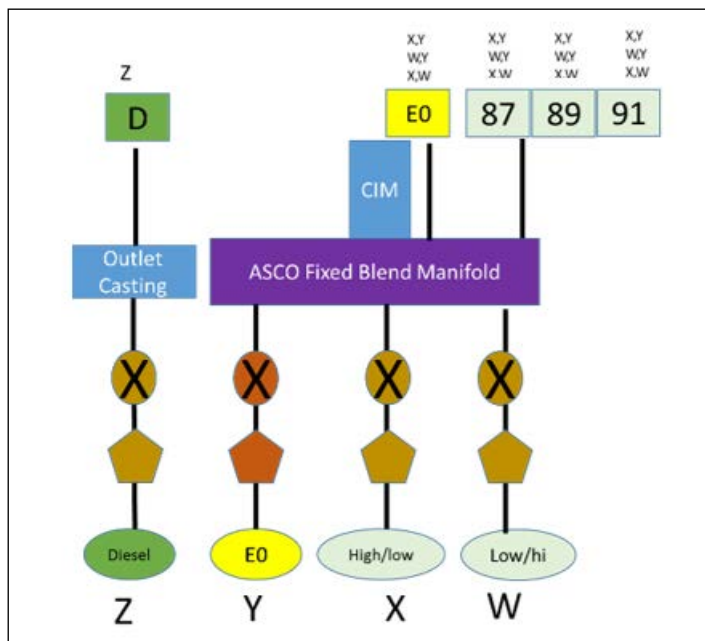
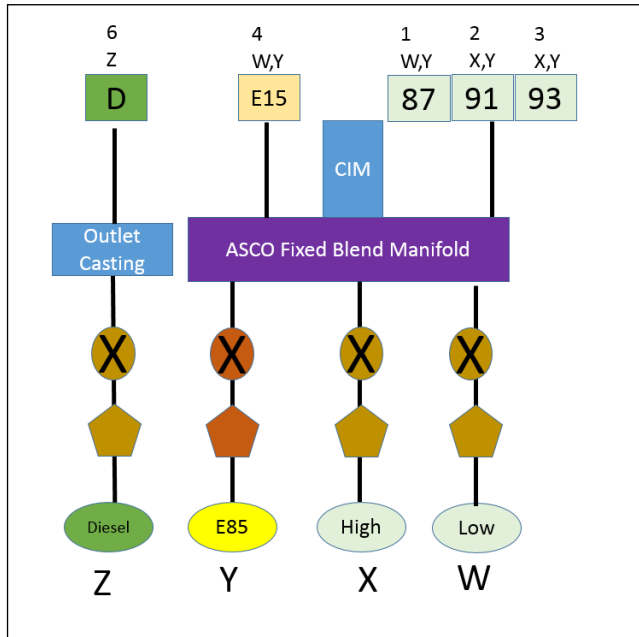

Figure 5-17: Blend Ratio (Model #NF4)



Following table provides example for blend ratio - NF2/NF4, 3-1+1; 3 hose multi-hose hybrid blender:

Button Grade	Delivered Product	Button Location	NF2/NF4 Example Inlet Product Percentages				Entry to Program for the Target Delivered Product
			W (Low Grade)	X (High Grade)	Y (E85)	Z (Diesel)	
1	87 (Grade 1)	Middle Button	94%	0%	6%	0%	94
2	91 (Grade 2)	Right Button to Grade 1	0%	100%	0%	0%	100
3	93 (Grade 3)	Right Button to Grade 2	0%	91%	9%	0%	91
4	E15 (Grade 4)	Left Button to Grade 1	88%	0%	12%	0%	88
6	Diesel (Grade 6)	Left Button to Grade 4					N/A

Dispenser Blender Piping to Hose Fitting Configuration

Figure 5-18: Encore Dispenser Blender Piping to Hose Fitting Layout (Model # NN1, NN2, NN3, NJ0, NL0, NL1, NL2, NL8, and NJ2)

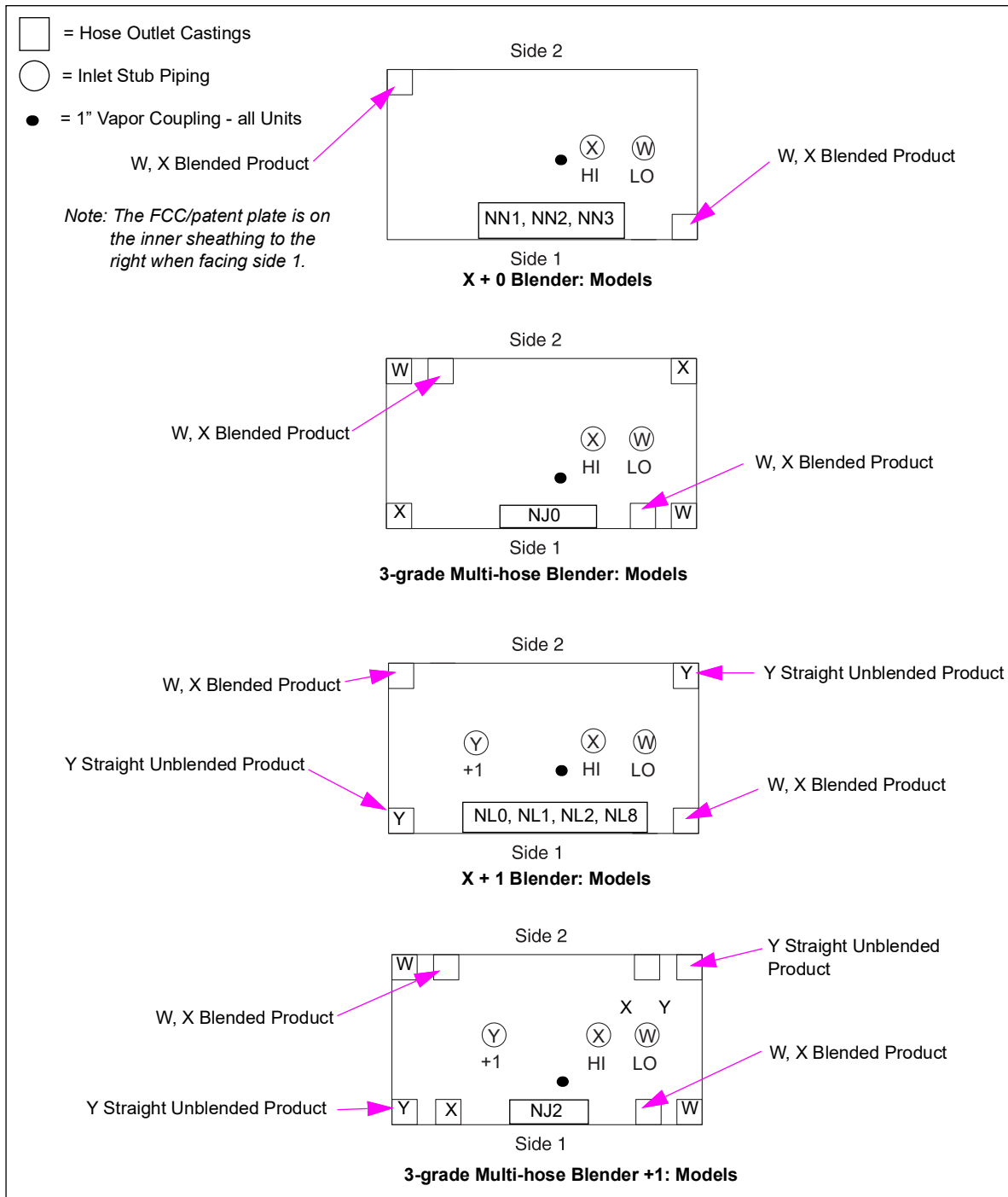

WARNING

For 3+1+1 and 3+2 units, certain fueling positions are designated and equipped for high alcohol blends or products. When installing such units, you must ensure that high alcohol products or grades go through product lines designed for them. Failure to follow this may result in leaks and/or premature failure of the unprotected components.

Figure 5-19: Encore Dispenser Blender Piping to Hose Fitting Layout (Model # NL3 and NJ4)

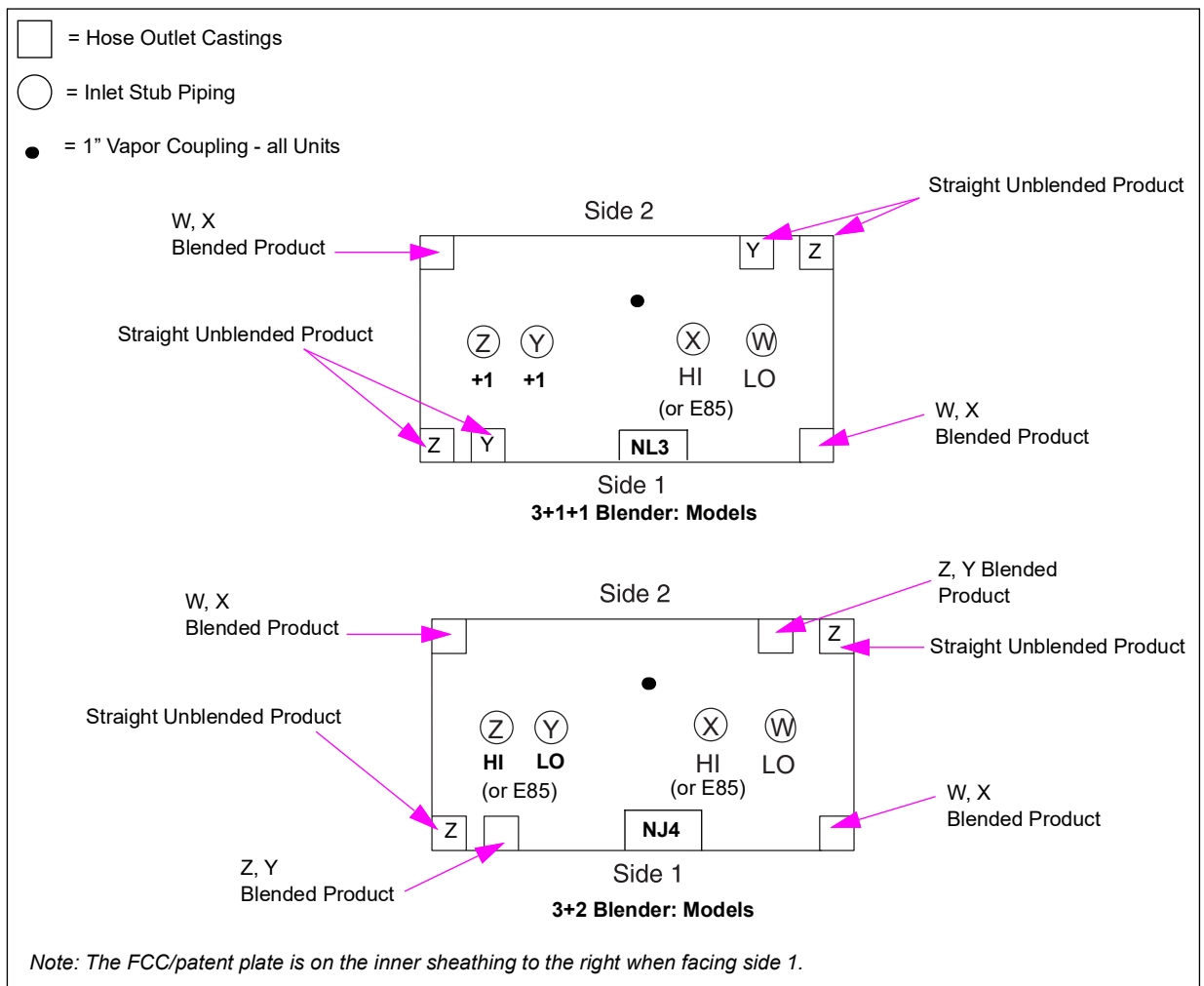
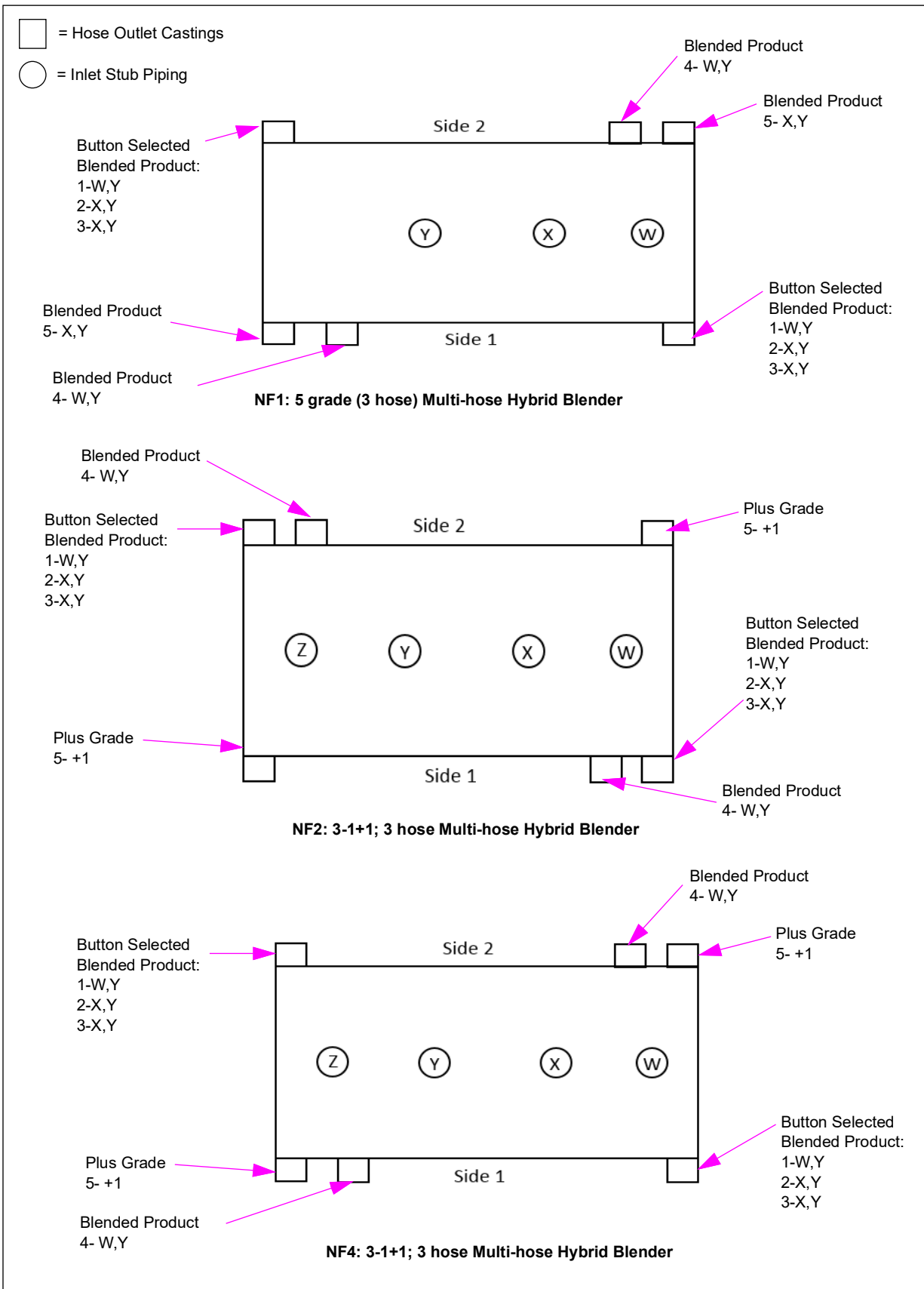

Figure 5-20: Multi-hose Hybrid Blender (Model # NF1, NF2, and NF4)



Pump Blender Configuration

For pump (MPD) configuration, refer to “[Pump \(MPD\) Configuration](#)” on [page 5-8](#).

Figure 5-21: Encore Pump Blender Product Inlets

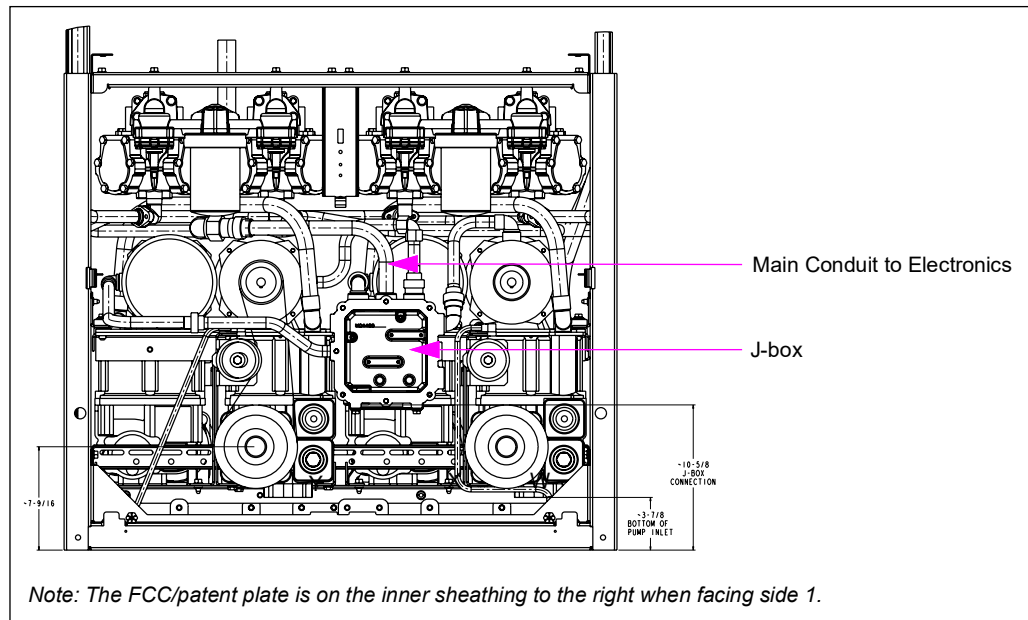

Model #	Pump Blender Model Description	Encore Inlets	Product Inlets (Typical)
NN5	Blender Pump 3+0		
NN6	Blender Pump 4+0	W, X	W = Lo Product X = Hi Product
NN7	Blender Pump 5+0		
NJ1	Multi-hose Blender Pump 3-grade 6-hose		
NL4	Blender Pump 2+1		W = Lo Product X = Hi Product
NL5	Blender Pump 3+1		W = Lo Product X = Hi Product
NL6	Blender Pump 4+1	W, X, Y	Y = +1 Straight/Unblended Product
NJ3	Multi-hose Blender Pump 3+1-grade 8-hose		

Notes:

- W = Product 1 (**On Blenders only** Product 1 is **always** Lo Product)
- X = Product 2
- Y = Straight/Unblended Product Inlet

Encore Pump Blender Piping to Hose Fitting Configuration

Figure 5-22: Pump Blender Piping to Hose Fitting Layout

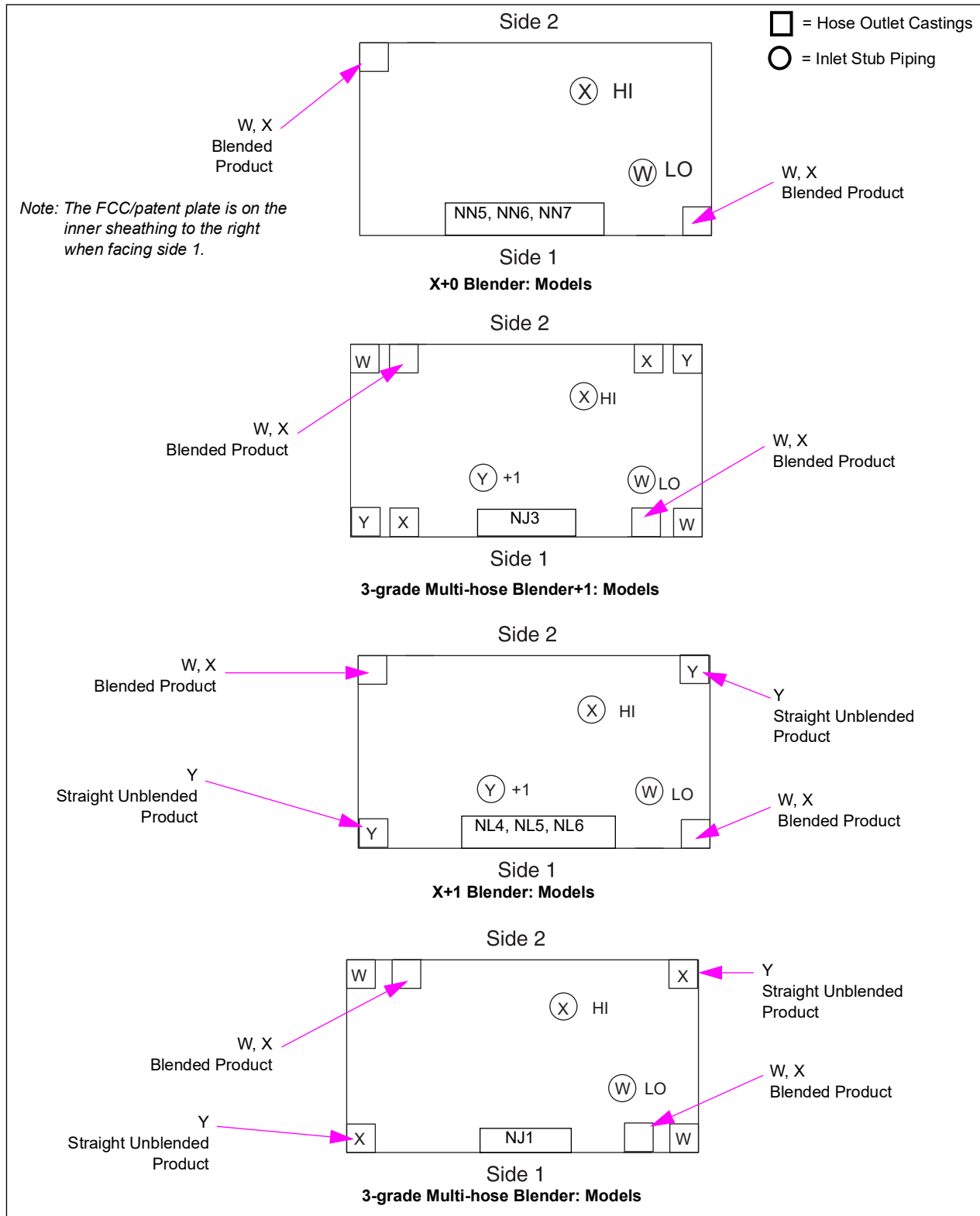

6 – Installing Units on Island

Mounting Unit to Island

Before placing the unit on an island, determine the correct location of piping for the unit involved and verify the proper orientation of the unit. A common installation error is to install the unit backward, resulting in required modifications or delay in installation.

Mount the unit using mounting bolt locations specified.

Fill in any openings from the smaller length Encore cabinet to the potentially longer pit box opening for The Advantage Series wide frame or other units. Seal as required.

Where low temperatures are expected, dispensing equipment, including hanging hardware, must be insulated, heated, or located in a temperature-controlled enclosure suitable for UL class 1 division 2 environment to prevent DEF from freezing.

When the unit is located in class 1 where high ambient temperatures are common, consider insulating the dispenser or placing it in a location where it is out of direct sun to maximize shelf life of DEF.

When mounting dispensers for DEF directly to the island, install sumps to prevent leaks and spills from migrating off site.

Lifting Encore Units

WARNING

Lifting heavy equipment can be hazardous.

Equipment could fall and cause severe injury or death.

Use lifting equipment of proper capacity and factor of safety when moving or positioning the unit. Stand clear from pump/dispenser when lifting and lowering.

Before mounting the unit to the island, verify if the pit box and unit base are compatible. Some pit box plates have rain lips that require modifications before placing the Encore unit on the plate. If the Encore unit does not fit properly onto the pit box plate, the unit will have to be lifted according to the instructions in this section and moved to a safe work area. Refer to [“Encore Elevation Diagram \(Encore 550 with SMART Meter\)”](#) on [page A-21](#) and [“Encore Elevation Diagram \(Encore 500 S with SMART Meter\)”](#) on [page A-22](#). If this modification is not required, do the following, and then proceed to [“Before Mounting Unit on Fuel Island”](#) on [page 4-9](#).

To lift Encore Units with lifting hooks, proceed as follows:

- 1 Verify if the hoisting brackets are tight. Use the bolts provided with the brackets or grade 8 bolts.
- 2 Use three nylon slings (safety lift factor of 5), four screw pin shackles, and hoisting brackets to lift the unit onto the island (see [Figure 6-1](#)).

CAUTION

Do not run slings around columns or under the upper piping housing. This will damage the columns or sheathing.

Figure 6-1: Lifting with Hoisting Brackets

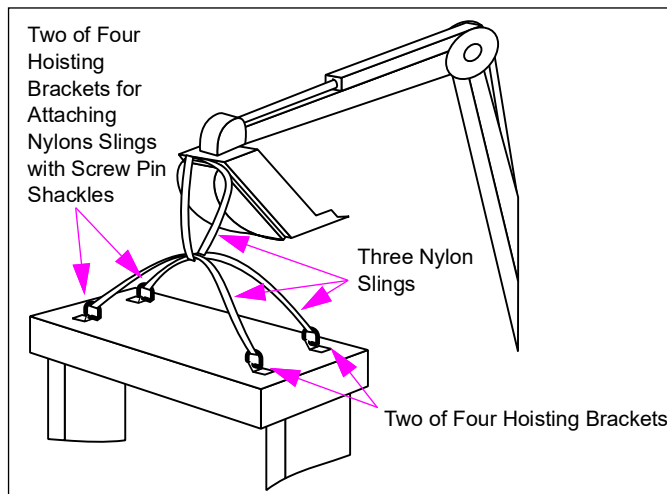

- 3 Lift and position the unit to the work area for modification or onto the island.
Note: If a side column conduit is used, take special care to avoid damage to the conduit when lowering the dispenser to the island.
- 4 Remove the slings and shackles.

To lift Encore Units without lifting hooks, proceed as follows:

Note: If lifting hooks are preferred on Encore units, they are available in kit M19010K001.

- 1 Refrain from attaching any outer canopy. If the unit has an outer canopy already attached, remove it.
- 2 Adjust the forklift tines so they are level with the upper housing and centered within the inner sheathing (see [Figure 6-2](#)).

Figure 6-2: Centering Forklift Tines

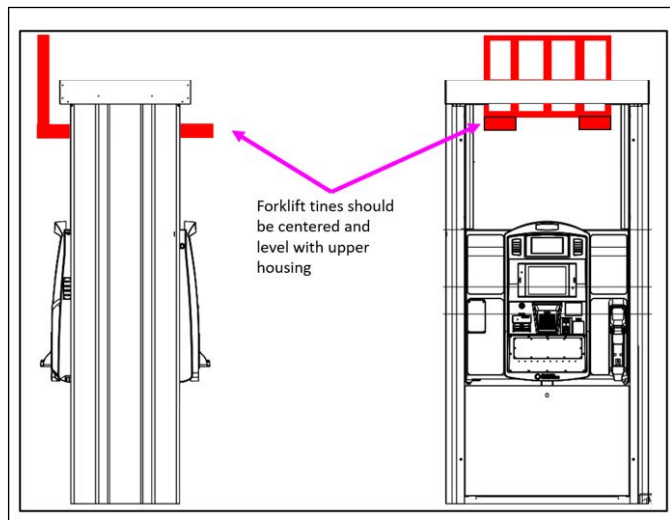

- 3 Place a pad on the forklift tines so that they can fit underneath the upper housing without damaging the unit or sheathing (see [Figure 6-3](#)).
- Note: A pad can be anything that sufficiently protects the upper housing from being in direct contact with the forklift tines. This can be foam padding or cardboard.*

Figure 6-3: Lifting without Brackets

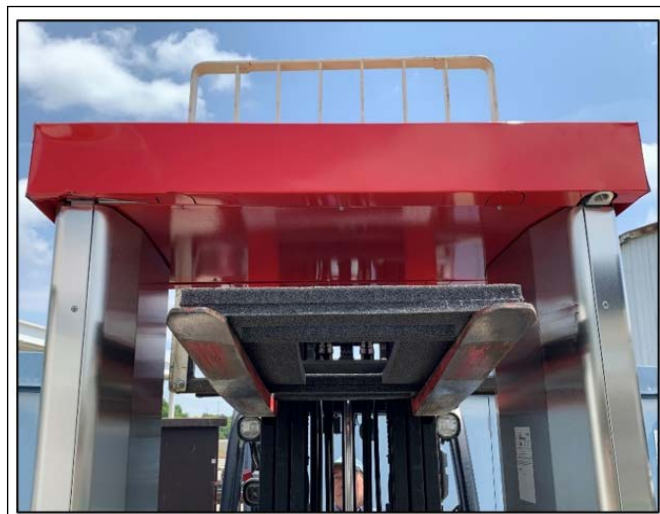

- 4 Slowly raise the forklift tines until the pad contacts the upper housing.
Note: When transporting the unit, take care to avoid bouncing or swinging the unit. This may damage the unit.
- 5 Lift and position the unit to the work area for modification or onto the island.
Note: If a side column conduit is used, take special care to avoid damage to the conduit when lowering the dispenser to the island
- 6 Remove the pad.

Determining Unit Side and Type

Before lifting the units onto the island, note the following:

- For units manufactured before January 2003, model labels are located on side 1.
For units manufactured after January 2003, the FCC/Patent labels are located on the inside sheathing on the right when facing side 1.
- Refer to the unit model label to determine if the unit to be installed is an MPD (dispenser or pump) or a blender (dispenser or pump).
- Use the following table to locate the appropriate configuration for your unit.

For This Configuration	Proceed to
Dispenser (MPD)	"Dispenser (MPD) Configuration" on page 5-1
Pump (MPD)	"Pump (MPD) Configuration" on page 5-8
Dispenser Blender	"Dispenser Blender Configuration" on page 5-10
Pump Blender	"Dispenser Blender Piping to Hose Fitting Configuration" on page 5-16
Pump STP	"J-box and J-box Conduit Installations" on page 7-5
Pump Self-contained	"Connecting to ISD Vapor Flow Meter" on page 7-29
Ultra-Hi Dispenser	"Dispenser (Ultra-Hi) Product Inlets - Standard Installation" on page 5-5
Encore Foundation 1 to 6	"Encore Foundation Diagrams: 2 to 9 (Dispensers with Piston Meters)" on page A-12
Encore Foundation (SMART Meter) 1 to 2	"Encore Elevation Diagram (Encore 550 with SMART Meter)" on page A-21

Connecting Pump/Dispenser Inlet Pipes

WARNING

DEF, flexible fuels such as biodiesel; high alcohol percentage fuels, and so on, may be incompatible with certain plumbing materials and hydraulic components.

Use recommended sealant, Loctite® #567 (Part Number 56747) and Loctite Primer-N 7649 (Part Number 21347) for DEF pipe threads. **Do not use thread tape.**

Use of incompatible materials or components with alternative fuels such as E25/E40 and E85, or DEF, can result in leaks or unexpected failures of components resulting in fire or explosion or environmental damage. To install components in E25/E40 and E85 units, refer to [“Important Requirements for E25/E40 and E85 Units”](#) on page 4-3.

When dispensing alternative fuels such as E25/E40 and E85, or DEF, verify with the manufacturer of the material or component that all plumbing components are compatible with the fuels or DEF being dispensed. Do not replace the dispenser or pump parts with those incompatible with the fuel or DEF involved.

WARNING

The shear valves must be installed correctly.

Improperly or insufficiently anchored shear valves can lead to fire or explosion that could result in severe injury or death.

Anchor all the shear valves as per the manufacturer's instructions.

Note: Pumps do not have to use shear valves, except in special circumstances. Following procedure for a pump is identical to that of a dispenser, except that a shear valve may not be used. The contractor must provide and install pipe unions whether shear valves are used or not.

IMPORTANT INFORMATION

National Pipe Taper (NPT) pipe threads can at times be difficult to seal during installation or later, because of various conditions, such as minor thread damage, contamination, slight thread imperfections, poor assembly practice, and other reasons. Gilbarco has found that although NPT threads can be sealed normally with a good quality pipe sealant alone (the normal recommendation), on many occasions, fewer issues are created during installation by using a combination of sealant and Teflon pipe tape. The additional expense incurred to apply both will save money for the installer in the long run by spending less time correcting leaks during installation.

When using a Teflon pipe tape, it is extremely important to apply it properly so that no tape stringers are created to enter the hydraulic system. Tape stringers can cause serious issues with valves, nozzles, and other hydraulic components. For information on how to properly use the Teflon pipe tape and thread sealant to ensure fewer installation issues and fewer subsequent pump/dispenser problems, refer to ["Inlet Pipe Assembly"](#) on [page 6-7](#).

This information and recommendation does not apply to hanging hardware connections. Damage to aluminum parts of the hanging hardware or dispenser can occur since it is very difficult to control proper torque tightening because of the thread-assembly friction characteristics of Teflon tape.

To connect pump/dispenser inlet pipes, proceed as follows:

- 1 Remove the vertical low hydraulic cabinet brace (found only in some units) to gain access during the installation of plumbing. Reinstall this brace after you complete the installation of the plumbing.

For units with a shear valve, a contractor-provided union must be installed on the shear valve. For proper tightening of the union to the shear valve, refer to the shear valve manufacturer's instructions. For units without shear valves, a contractor-provided union must be installed on the ground stub pipe.

For additional shear valve information, see [Figure 6-6](#) on [page 6-9](#). Since Ultra-Hi units require special considerations, ensure that you read and understand the information on shear valves later in this section for those units.

CAUTION

The shear valves or other dispenser components can be damaged or broken if improper wrench techniques are used. The installer must use two wrenches so that stress is not applied to the shear portion of the valve during tightening.

- 2 To maximize installation versatility or ease, standard Encore series units are shipped without inlet piping, and Ultra-Hi units are shipped with inlet plumbing. The installer provides and installs the plumbing in the lower hydraulics cabinet when required. Where required, use a UL-approved sealant suitable for the applicable fuel type.

CAUTION

Units used with alternative fuels, such as ethanol (E25/E40 and E85), biodiesel, or others, require contractor-supplied plumbing components to be suitable for use with such components. Consult your part suppliers for recommendations for their hydraulic parts based on the fuel types to be utilized.

Fuel leaks or component failure may occur if the components are not compatible with these fuels.

- 3 Ensure that you remove any shipping plugs or caps that may be present in the pipes, shear valves, and unions. Leave the mounting bolts a little loose at this time to allow more adjustment when aligning the piping.

Notes: 1) The contractor-supplied pipe and fittings must be 1-1/2-inch NPT schedule 40 black iron. The Ultra-Hi pipe and fittings must be 2-inch NPT schedule 40 black iron. Vapor recovery is 1-inch NPT.

2) Flexible pipes are not allowed within the dispenser (not applicable to fluid lines transferring DEF).

For information regarding the valves or shear valves required for vapor recovery return lines consult the local regulatory agencies.

To ensure proper operation of the shear valve during a vehicle collision, all piping above the shear valve must be secured to the lower cross brace using U-bolts sized according to the plumbing involved.

Inlet Pipe Assembly

To ensure proper sealing during installation, assembly of pipe nipples to all 1-1/2 inches NPT inlet tubes must follow the following guidelines:

- Ensure that the threads are of good quality, full-NPT threads without obvious damage for all pipe nipples.
- Assemble using 1/2-inch wide Teflon thread-seal tape.
- Assemble using a high-quality, UL-approved sealant that will not harden or wash out with the fuel being dispensed. Use Loctite #567 (Part Number 56747) PST pipe sealant with PTFE (also known as Loctite 567) or equivalent.

To assemble the inlet pipe assembly, proceed as follows:

- 1 From the pipe nipple end (about 2 to 3 threads), wrap the inlet pipe with Teflon tape [12 to 15 revolutions (see [Figure 6-4](#) on [page 6-8](#))].

Note: Not applicable for DEF dispensers.

CAUTION

Do not use tape at the very end of the pipe nipple to avoid tape entering the dispenser hydraulics. Tape in the hydraulics can cause failures of valves, nozzles, or other significant problems.

DEF pipe threads: Use recommended sealant, Loctite #567 (Part Number 56747) and Loctite Primer-N 7649 (Part Number 21347) for DEF pipe threads. **Do not use thread tape.**

CAUTION**Applicable to Dispensers Rated for E25/E40 and E85 Use:**

Do not use tape at the very end of the pipe nipple to avoid tape entering the dispenser hydraulics. Tape in the hydraulics can cause failures of valves, nozzles, or other significant problems.

Use only UL-listed TPS PTFE pipe sealant manufactured by SAF-T-LOC International Corp.

Use only UL-listed Taega Technologies Inc. Teflon tape.

*Note: Teflon tape must be used **only** at the inlet pipe connection.*

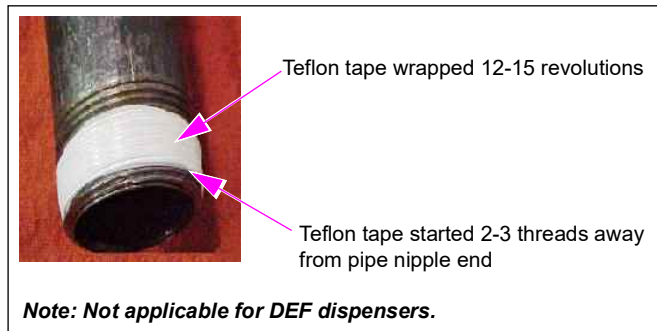
Figure 6-4: Inlet Pipe Wrapped with Teflon Tape

- 2 Apply a moderate bead of sealant completely around the nipple end at the edge of the Teflon tape (see [Figure 6-5](#)).

Note: For DEF pipe threads, ensure that you apply the primer before applying the sealant. Follow the manufacturer's instructions.

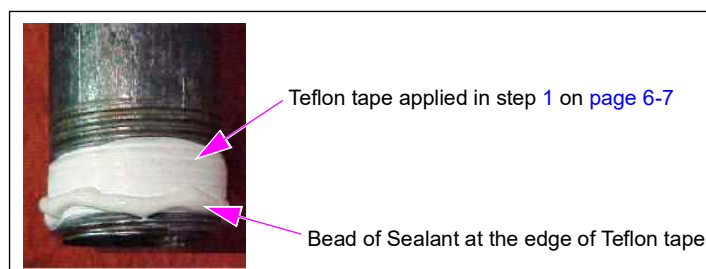
Figure 6-5: Bead of Sealant at Teflon Tape Edge

- 3 After the sealant has been properly applied, tighten the connection to 130 foot-pounds.

Figure 6-6: Dispenser Inlet Piping and Safety Brace

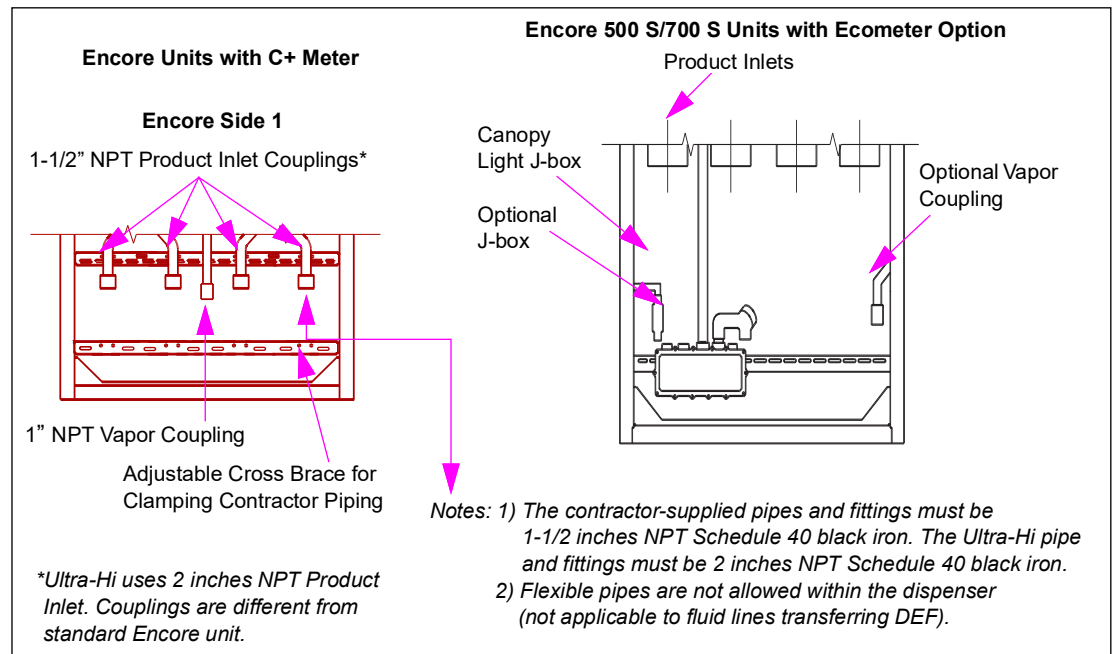

WARNING

Always use the provided adjustable cross brace to secure plumbing in the dispenser, or the shear valve may not operate properly during a vehicle collision.

The cross braces are not an optional feature. Do not remove them from the Encore fuel dispenser.

Also, use of non-rigid piping materials, such as field-bendable tubing, to connect to the inlet may also result in the shear valve not operating properly during a collision.

Use of black iron pipe inside the dispenser is required for fuel lines at the outlet of the shear valves.

- 4 Loosely connect the union halves together.

CAUTION

Do not use pry (crow) bar to position pump/dispenser over conduit or pipes. This could damage valves, conduit, or other parts of the unit.

- 5 Double-check the alignment of the frame, conduit, and pipes. Secure the piping to the safety brace using U-bolts or pipe clamps that are supplied by the contractor.

Note: Misaligned piping can result in a leak.

⚠ WARNING

For Ultra-Hi units, do not permanently remove the strainer under any circumstances to accommodate the shear valves from certain manufacturers that may not properly position the shear section of the valve as shown in [Figure 6-7](#).

Use a Morrison or equivalent shear valve to ensure proper position of the shear section of the shear valve.

Failure to use the strainer could result in failure of the valves or meters, void warranty, and create a safety hazard with an improperly operating valve.

Figure 6-7: Shear Valve at Grade

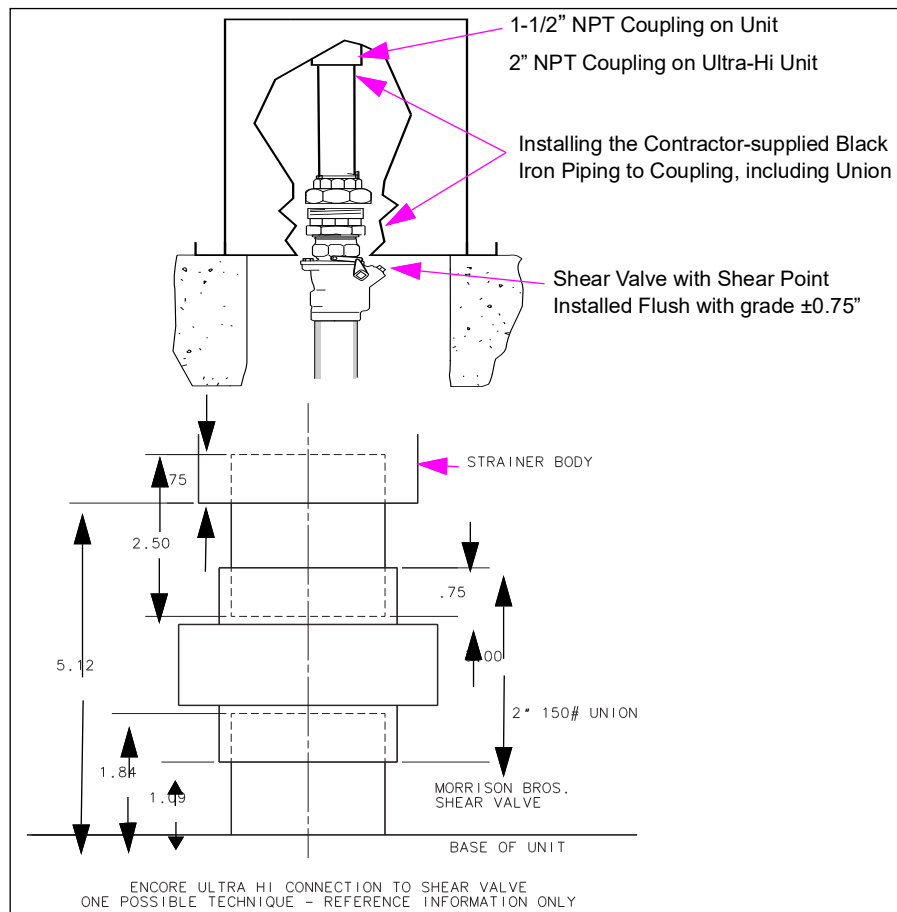

Notes: 1) Regular (non-double wall) shear valve is shown.

2) OPW supplies an Encore Ultra-Hi compatible double poppet shear valve with a union top (OPW Part Number 10RUP-2006).

3) It is a mandatory code requirement that the shear section of the shear valve be within $\pm 3/4$ inches (or to shear valve manufacturer's requirement, whichever is tighter) from the plane of the bottom of the base of a dispenser. Not all shear valve styles allow the maintenance of this tolerance for Encore Ultra-Hi units. A N23047 single poppet male top Morrison 2 X 2 636M-0200AV or a code-approved equivalent shear valve meets the code requirements. Do not modify the dispenser plumbing (for example, remove the strainer housing) to accommodate other model valves, or install units such that the shear groove of the shear valve is not within $\pm 3/4$ inches of the base plane of the dispenser. Use a Check Valve (N23274) between the union and strainer housing to ensure that the shear section is properly located.

- 6 Tighten the union halves together.
- 7 Tighten the anchor bolts at this time. Verify if the shear valves are properly tightened to the pit box or shear valve anchor bracket, as required. If removed earlier, reinstall the vertical cabinet brace in the lower hydraulic cabinet.

For Ultra-Hi installations:

- Selection of proper components mounted to the bottom of the strainer housing is critical in maintaining the proper location of the shear valve groove of the shear valve to the base plane of the dispenser. You must follow the shear valve manufacturer's required positioning for this groove.
- A check valve is strongly recommended. When installed, Gilbarco recommends using N23274, which is about 2-1/2-inches long and can take the place of the close nipple located above the union. Failure to install a check valve here can result in fuel sale indication when the fueling position is activated with the nozzle closed and the check valve back at the STP is leaking.
- A union is required above the shear valve.
- A Morrison male end Shear Valve [N23047 (Morrison # 636M-0200AV)] can be used to properly maintain the position of the shear groove. The installer must verify if other manufacturer's shear valves will ensure proper positioning of the shear groove as per their specifications.
- For retrofit sites, it is allowable to extend the horizontal nipple on the Encore inlet to relocate the turn down elbow that will allow the vertical pipe to be U-bolt connected to the Encore cross member. The union and shear valve must still be mounted as recommended.
- Not all double poppet shear valve models or styles will fit the Ultra-Hi unit.
- Other combinations of unions, check valves, and shear valves may be possible and still maintain proper location of the shear groove.
- Removal of a strainer from the system will void warranty.

Follow the shear valve manufacturer's instructions for installation procedures, testing, and so on.

- Install the shear valve on each product inlet pipe.
Note: Encore dispensers require 1-1/2-inch male top shear valves. Gilbarco strongly recommends using double poppet shear valves that shut off flow from both storage tanks and internal to the unit (for example, OPW #10BHMP or Exxon® - OPW # 10RMSP). The Encore Ultra-Hi dispensers use a 2-inch male top shear valve (for example, Morrison Bros. 2" 636 m).
- For Ultra-Hi units, install the shear valve on each 2-inch inlet and outlet.
- Install a shear valve on the master dispenser satellite outlet and at satellite inlet.
- Do not mount the shear valve upside down.
- Ensure that the valve linkage is accessible and has no interference to open or close from other piping, structure, or components.
Note: The dispenser product inlet pipes must be aligned with the shear valve. Do not restrict shear valve linkage with pipes, braces, and so on.
- Test shear valve operation.

- Close the shear valve until equipment start-up. Cap the inlet pipe. This prevents dirt and other particles from entering the product line. It also prevents fuel spillage.

Figure 6-8: Shear Valve

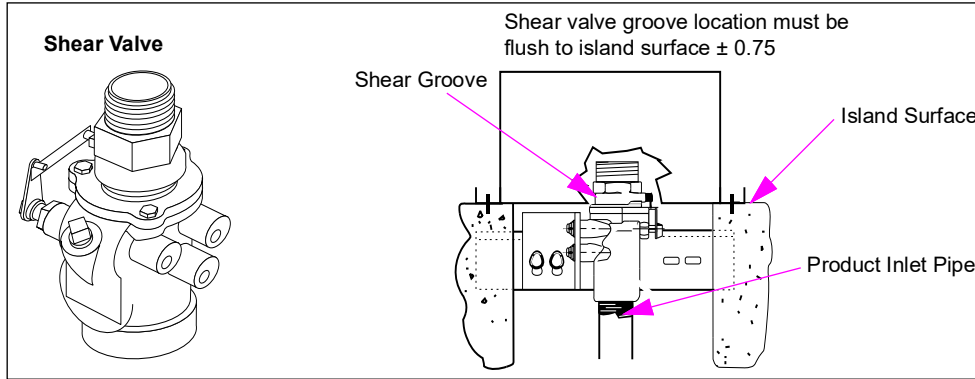

Connecting Vapor Return Line to Vapor Shear Valve

Do not create any liquid traps when connecting the vapor return line to the vapor line shear valve (see Figure 6-9). A liquid trap is a low spot in the vapor return line that can accumulate fuel and cause blockage, which can cause a system to fail vapor recovery certification tests or create operation issues with vapor balance nozzles.

- Notes:*
- 1) The contractor must provide and install the pipe union for connecting to the 1-inch NPT coupling in the unit.
 - 2) Follow the vapor line shear valve's manufacturer information regarding mounting of the shear valve to the unit.

Figure 6-9: Correct Vapor Line Connection Method

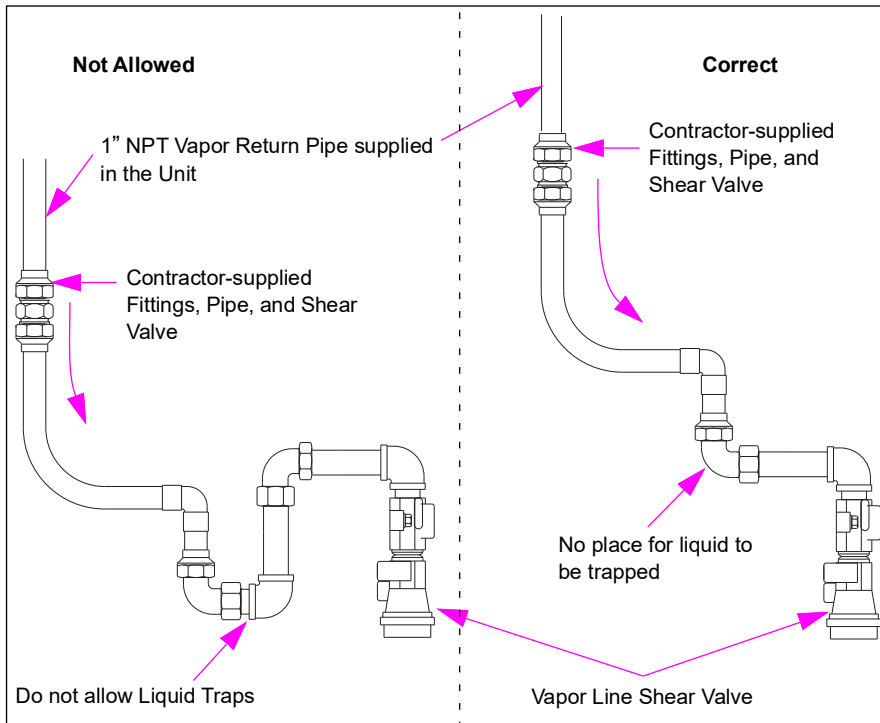

Anchoring Pump/Dispenser to Island

Note: Pumps do not normally require shear valves. Following procedure for a pump is identical to that of a dispenser, except that the shear valve may not be used.

⚠ WARNING

Improper anchoring of units could cause damage, severe injury, or death resulting from the unit tipping over from the impact or drive-off.

NFPA 30A requires the anchoring of pumps/dispensers. Securely install anchor bolts at all anchoring locations as shown on foundation diagrams for safe operation of shear valves and hose breakaways.

To anchor pumps/dispensers to the island, proceed as follows:

- 1 Verify if the shear valves are firmly anchored to the island form [concrete or pit box (see [Figure 6-10](#))].

Note: If the shear valve is not anchored properly, it may not operate correctly during a severe impact. Follow the shear valve manufacturer's instructions.

Figure 6-10: Anchoring Shear Valves Using Anchor Brackets

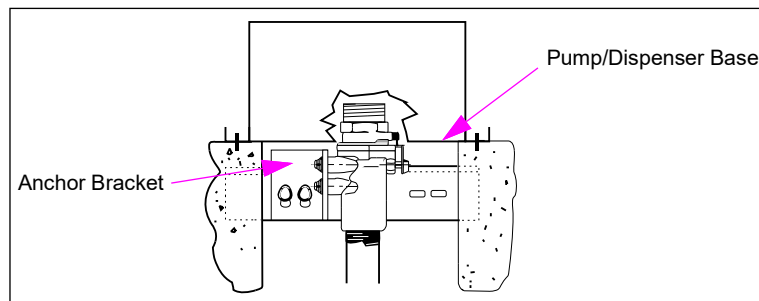

- 2 Loosely anchor the pump/dispenser to the island according to the foundation layout locations, using all the required anchoring points as follows:
 - Use 1/2 inch anchor studs with heavy duty large washers (slot designed for that size).
 - Use bolts or studs that are of 5-grade steel.
 - Use hardware that is corrosion-protected or resistant.

Note: Do not use plastic, low strength, or pallet bolts.

 - Studs/bolts must be securely anchored to the island or pit box (see [Figure 6-11](#)).
 - For additional important information, refer to the anchor or pit box manufacturer's instructions.

Figure 6-11: Anchors for Pump/Dispenser

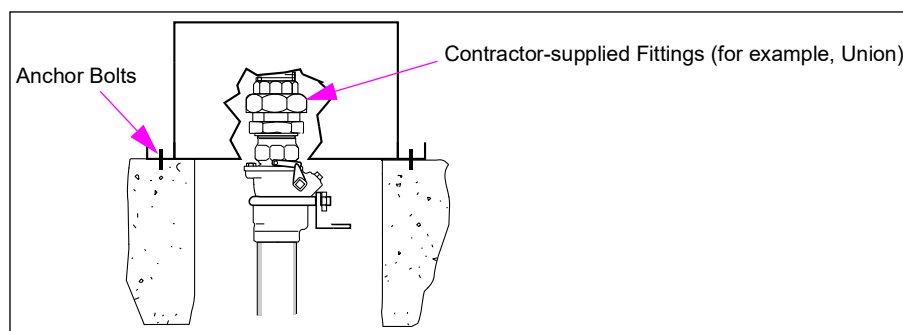

DEF Dispensers - Skid Tank Interface

Figure 6-12 shows the skid tank interface for DEF dispensers. For foundation diagram, see Figure A-24 on page A-24. Ensure that you read and understand the skid tank manufacturer's instructions for installation and operation. Gilbarco instructions may override the wiring instructions to the dispenser (for example, sharing dispenser power or communication wiring, sharing conduit with other equipment, and so on).

Figure 6-12: Skid Tank Interface for DEF Dispensers

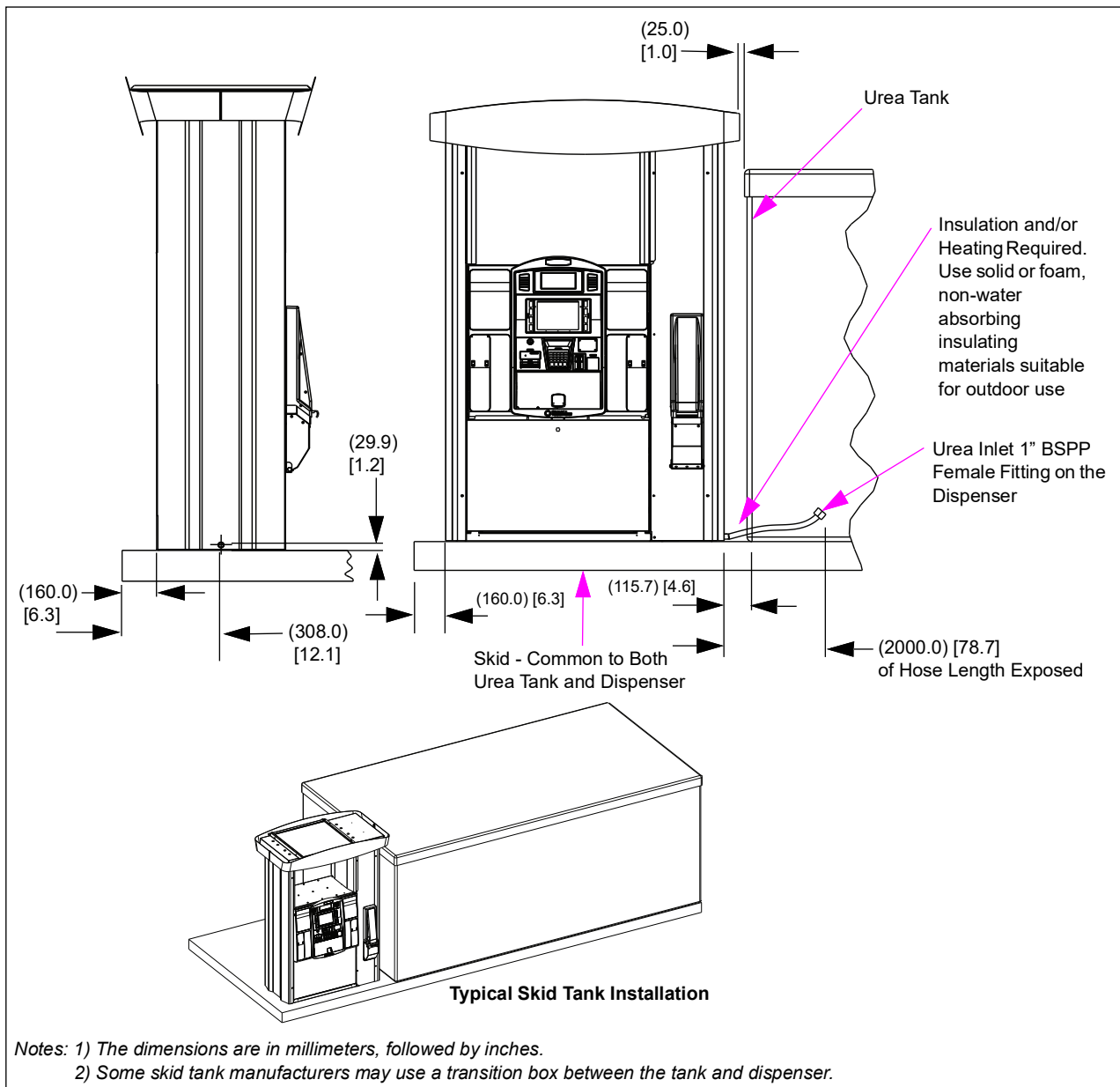

WARNING





To meet regulatory requirements, the DEF inlet must be installed from the side of the DEF module. Inlet cannot be installed from a pit box under the DEF cabinet.

7 – Installing Conduit and Wiring in Unit

Installing Conduit Within Unit

The standard Encore units are not shipped with the J-box. All electrical runs for the Encore units are to be provided at the site by the installer unless a J-box is ordered for the unit. The conduit may be routed through the dispenser pit box or external to the pit box through the side column. The instructions in this section also contain one additional possible approach to routing the conduit into the dispenser versus through the dispenser pit box. Side entry to the electronics cabinet bottom eliminates the necessity to penetrate the pit box with the conduit and the potential cost and reliability issues.

Note: Gilbarco does supply J-box kits. For information on how to order a J-box, contact a Gilbarco customer service representative at 1-800-800-7498 (USA and Canada). For additional information on J-box kits, refer to MDE-4084 Encore Junction Box Retrofit Kit M01483K00X Installation Instructions.

 WARNING	
	All standard safety precautions for hazardous locations are to be followed and maintained while this work is being performed.
	Do not use electrically powered (battery or corded) tools in the work area. Do not smoke or allow open flames in work area.
	Always remember to power down all circuits before performing work. Failure to following these precautions may result in serious injury or death.

Following instructions are for adapting the conduit rising from the right of the pit box when facing side 1 (or left when facing side 2). Also, shown is the option where the conduit penetrates the pit box.

For Installations in Canada

For installations in Canada the applicable code is CSA C22.1, The CEC. Other codes may apply and should be verified with the authority having jurisdiction.

IMPORTANT INFORMATION

(Applies to the province of British Columbia only)

The **British Columbia Safety Authority** issued a decision stating that data cables and AC cables in the same conduit do not comply with the requirements for communication wiring as specified in CEC rule 60. In British Columbia, installing communication circuits, such as data cables and AC cables, in the same conduit as AC circuits is contrary to the CEC rule 60.

- New installations must have separate conduit for data/communication cables and power cables in the following circumstances (wiring for two-wire, data, communications, intercom, video, Ethernet, GLRE, must be in a separate conduit from the dispensers power and light conduit):
 - All new installations of fuel dispensers or other electrical equipment, whether or not the raceways are exposed and made readily accessible as part of the installation process; or
 - In any event if the raceways are exposed and made readily accessible for any reason.
- Separate conduits are not required in respect of the repair, modification or replacement of one or more existing pieces of electrical equipment or components thereof unless the raceways are exposed and made readily accessible as part of the repair, modification or replacement.
 - “Components” include card readers in fuel dispensers
 - “Electrical equipment” includes a fuel dispenser and “replacement” means the substitution of one electrical component or piece of equipment with another having the same essential function and provided always that:
 - * Neither the electrical rating nor the characteristics of the equipment is altered; and
 - * The replacement components are of a type which do not invalidate the original certification mark.
- A raceway is exposed and made readily accessible if it can be removed or replaced without significant additional disturbance to the material enclosing or overlaying it, including without limitation excavation of soil, asphalt or any other material by mechanical means, provided that a raceway is not to be considered exposed and made readily accessible merely because one or both ends of the raceway become visible during the repair, modification or replacement of electrical equipment or components.

Field wiring through the side column location can be installed as follows:

Note: These instructions are for units without pre-installed J-boxes.

- 1 On the lower right corner of the frame end, locate area in between center brace [see [Figure 7-1 \(i\)](#) and [\(ii\)](#)].

Figure 7-1: Encore Frame Assembly with Conduit

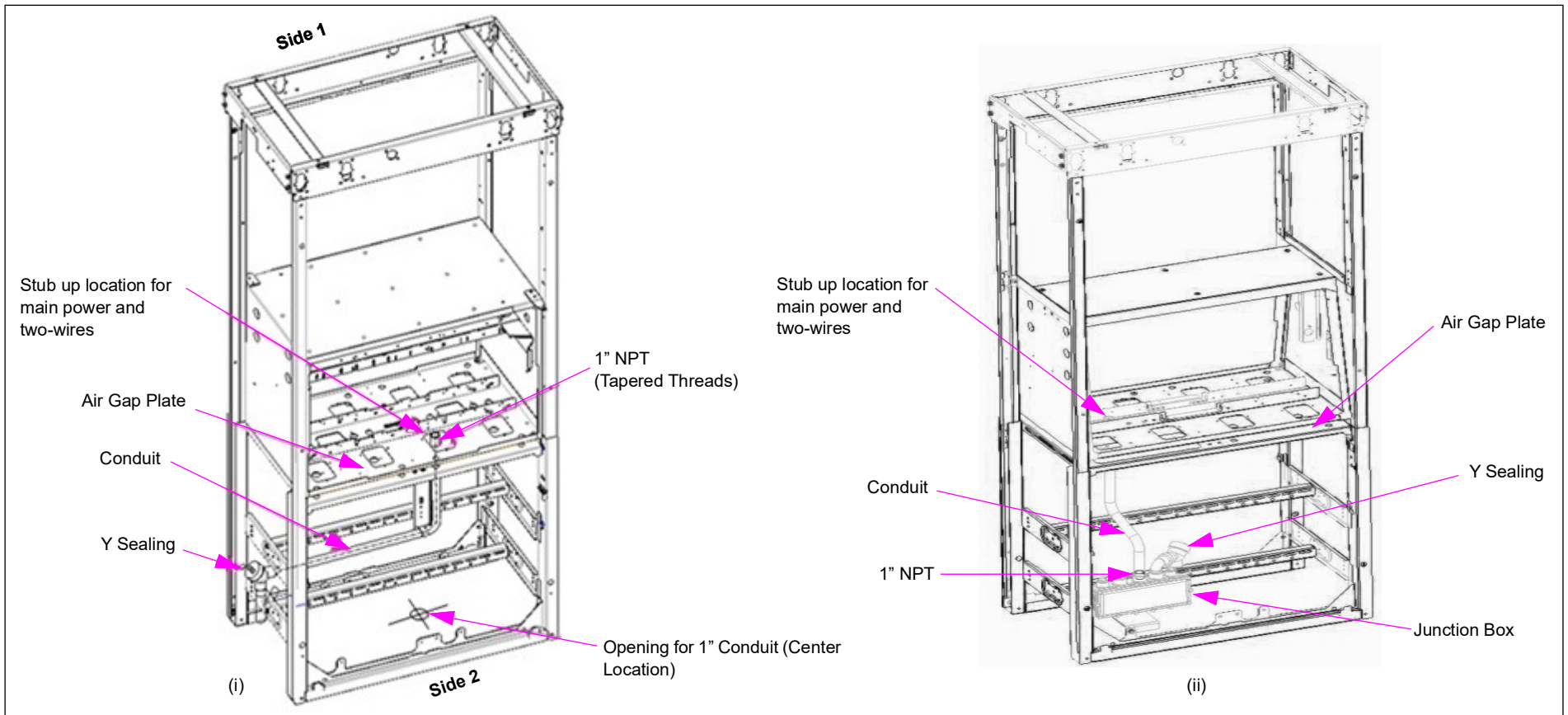

Note: The conduit is finally run through air gap plates into the electronic module in the location shown in see [Figure 7-1 \(i\)](#) and [\(ii\)](#).

- 2 For the side column entry, run the field wiring conduit through a 1-inch trade size conduit stub up centered in the width of the location in between center brace of the lower frame.

- 3 For the side column entry, stub up must be inside the column and centered in the column as closely as possible.
Note: If stub up is not properly located in the column, it will interfere with the column outer sheathing.
- 4 For the side column entry, use a 1-inch trade size conduit stub up long enough to extend at least 1 inch above the lower center brace of the lower frame. Maintain the space between interior of the lower frame and the installed conduits (see [Figure 7-2](#) on [page 7-4](#) and [Figure 7-3](#) on [page 7-6](#)).
Note: Ensure that the conduit is vertically straight upon installation.
- 5 For the side column or pit box entry, thread the end of stub up using a 1-inch NPT (tapered threads) to use a sealing fitting. The use of a Killark® EY-3 or Killark ENY-3 is recommended. These fittings are compact and will fit inside the column (see [Figure 7-2](#)).

Figure 7-2: Killark Fittings

- 6 For the side column or pit box entry, install the sealing fitting to stub up. Tighten all fittings (minimum five full threads of engagement).

Installing J-box

To install the J-box, proceed as follows:

J-box Specifications

The Encore units are provided without the J-box unless the J-box option is specified at the time of order. Units sold in Canada are provided with a J-box. If you are replacing an existing unit, the installing contractor may connect and extend the existing field wires that are too short for Encore by providing and utilizing a class 1 division 1 explosion-proof J-box sized to conform to or exceed the requirements of both UL 87 and the NFPA 70.

Notes: 1) *These specifications may have requirements that are not identical.*

2) *Gilbarco supplies the J-box kits. For more information, refer to MDE-4084 Encore Junction Box Retrofit Kit M01483K00X Installation Instructions.*

J-box and J-box Conduit Installations

This section covers information regarding units with the factory-installed J-boxes or contractor-installed J-boxes. The J-boxes are commonly used when adapting units to existing field wiring and conduit or for Canadian installations. Depending on the installation, the electrician routes the conduit directly to the electronics cabinet, to a factory-installed J-box, or to an installer-supplied J-box, and then to the electronics cabinet.

Notes: 1) *For Encore units that are replacing older units, if the existing wire is too short to reach the cabinet connections and a splice must be made, the contractor must provide and use a class 1 division 1 explosion-proof J-box to make connections according to the code. Refer to “Before Mounting Unit on Fuel Island” on page 4-9.*

2) *Up to two J-boxes may be required per unit depending on the equipment involved and the existing wiring. One will be required for power and two-wire communications to the unit and the other for non-power wiring, such as speakers, call buttons, and so on.*

3) *The factory equivalent J-box kits are also available from Gilbarco.*

To install the J-box and related conduit, proceed as follows:

- 1 Open the CIM door on side 1 of the unit. For instructions, refer to *MDE-3804 Encore and Eclipse Start-up/Service Manual*.
Note: Side 1 has electronics module access to the field connections, boards, and wiring. The main J-box is installed on side 1 for units with a factory-installed J-box.
- 2 For units with the J-box installed, remove the box cover and retain for reassembly.
- 3 Verify if a seal-off Y fitting has been installed and sealed as a first connection where the conduit leaves the ground. This fitting must be in place and sealed before proceeding further. For more information, refer to *MDE-3802 Encore and Eclipse Site Preparation Manual*.

- 4 In all units where the J-box is used (factory or contractor-supplied), the following requirements are mandatory:
 - The connection of the conduit to the J-box must be made with a clearance of at least 9 inches from the pump/dispenser base to the bottom of the J-box connection stub. To accomplish this, the conduit can be routed to enter the J-box from the side or top.
 - The J-box must be securely fastened to the unit by means of a bracket or brace. It must not be held in place only by a conduit. Factory-supplied boxes are fastened only by a conduit.
 - Installation of the J-box and all fittings must be performed to allow the installer to turn any and all threaded fittings by a minimum of 45-degree angle in a single movement using appropriate tools (for example, pipe wrench).
- 5 It is not a requirement, but it is acceptable/allowable to secure field installed conduit to the fuel piping cross brace in the hydraulics cabinet (see [Figure 7-3](#)).

Figure 7-3: Cross Brace (Without Ecometer Option)

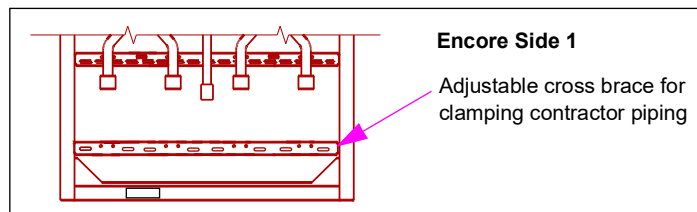

IMPORTANT INFORMATION

The cross braces are not an optional feature. Do not remove them from the Encore fuel dispenser.

- 6 For units with the J-box, run a 1-inch rigid conduit to the J-box entering the unit from side 2. Run any existing wiring to the main J-box through the 1-inch J-box conduit that enters the unit from side 2. Connect the 1-inch conduit with class 1 division 1 explosion-proof conduit union.

If the conduit is entering the unit from outside the dispenser pit box, refer to [“Electrical Related Items”](#) on [page 9-3](#) and [“Reference Information”](#) on [page 10-1](#) before proceeding.

Use an 8 X 1-inch diameter conduit, to run to the electronics cabinet of the unit from side 2. Use additional conduits and coupling, if required.

- 7 If required, install the conduit for call buttons, Ethernet, and speaker wires using similar procedures as outlined for the power conduit. However, when facing side 1, call button, and so on, the conduit must be to the right side of the unit and power wiring to the left. Ensure that you follow earlier steps and warnings for installing the conduit through the air gap plate or side of the electronics cabinet. If the unit requires a call button conduit, read and understand [“Installing Call Button/Speaker Conduit”](#) on [page 7-23](#). If the unit contains a lighted canopy, read and understand [“Lighted Canopy Conduit and Wiring Options”](#) on [page 7-25](#).

Note: Call button, Ethernet, and speaker wires cannot be in the same conduit as the power and two communication wiring to the unit. They must be in a separate conduit.

- 8 If the unit is equipped from the factory with a call button/speaker J-box and conduit, refer to wiring requirements in [“Installing Call Button/Speaker Conduit”](#) on [page 7-23](#).

Preparing J-box Field Conduit

To prepare the field wiring, proceed as follows:

- 1 Open the CIM door on side 1 of the unit. For instructions, refer to *MDE-3804 Encore and Eclipse Service/Start-up Manual*.
Note: Side 1 has electronics module access to the field connections, boards, and wiring. The main J-box is installed on side 1 for units with or without a factory-installed J-box.
- 2 Commonly, a field connection conduit runs through the side column to the J-box with a 1-inch NPT male end. Run all the field wiring through this field conduit. All wiring connections may take place in the factory-installed J-box. Before proceeding, refer to “[Electrical Related Items](#)” on [page 9-3](#) and “[Reference Information](#)” on [page 10-1](#).

In all units where a J-box is used (factory or contractor-supplied), the following are mandatory requirements:

- The connection of the conduit to the J-box must be made with a clearance of at least 9 inches from the pump/dispenser base to the bottom of the J-box connection stub. To accomplish this, the conduit can be routed to enter the J-box from the side or top.
- The J-box must be securely fastened to the unit by means of a bracket or brace. It must not be held in place only by a conduit. Factory-supplied boxes are fastened only by a conduit.
- Installation of the J-box and all fittings must be performed to allow the installer to turn any and all threaded fittings by a minimum of 45-degree angle in a single movement using appropriate tools (for example, pipe wrench).

WARNING



The bottom plate of the electronics cabinet and the top plate of the hydraulics cabinet are separated to provide an air gap between the electrical and hydraulic housings.



Loss of air gap integrity due to improper installation can allow fuel vapors into areas where they may ignite. The resulting fire and/or explosion can lead to serious injury or death.

Running the conduit through the air gap requires strict compliance with procedures outlined in this manual. No holes in air gap plates can be left unsealed following the installation.

WARNING



The electronics cabinet is an unclassified area and as such must be protected against flammable vapor entry.



Improper installation of the conduit through the side of the electronics cabinet may result in flammable vapors penetrating the electronics cabinet where it may ignite resulting in fire and/or explosion that can lead to serious injury or death.

Running the conduit through the side of the electronics cabinet requires strict compliance with the procedures outlined in this manual.

IMPORTANT INFORMATION

For conduit entry through the vapor barrier, the air gap penetration conduit must not be longer than 8 inches. This will allow removal of the dispenser (if required) in the future and accommodate wiring a new dispenser without pulling a new wire.

When a dispenser without a J-box is removed from the island, the conduit and wires will be cut immediately below the potting dam. This will leave enough wire to splice into a class 1, division 1, group C, and D explosion-proof J-box when a new (or previously removed) unit is installed/reinstalled over the containment box.

Use the information provided in [Figure 7-4](#) to feed wires into the electronics cabinet.

Figure 7-4: Typical Conduit Locations (Entry Through Air Gap)

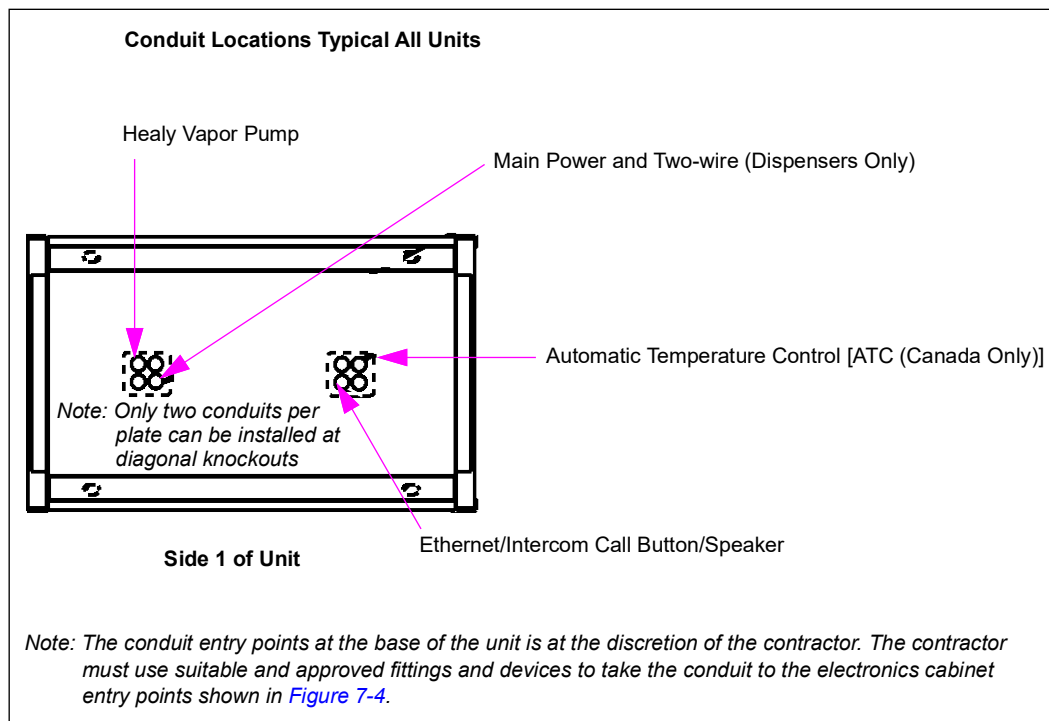

Figure 7-5: Typical Conduit Locations for Encore 900

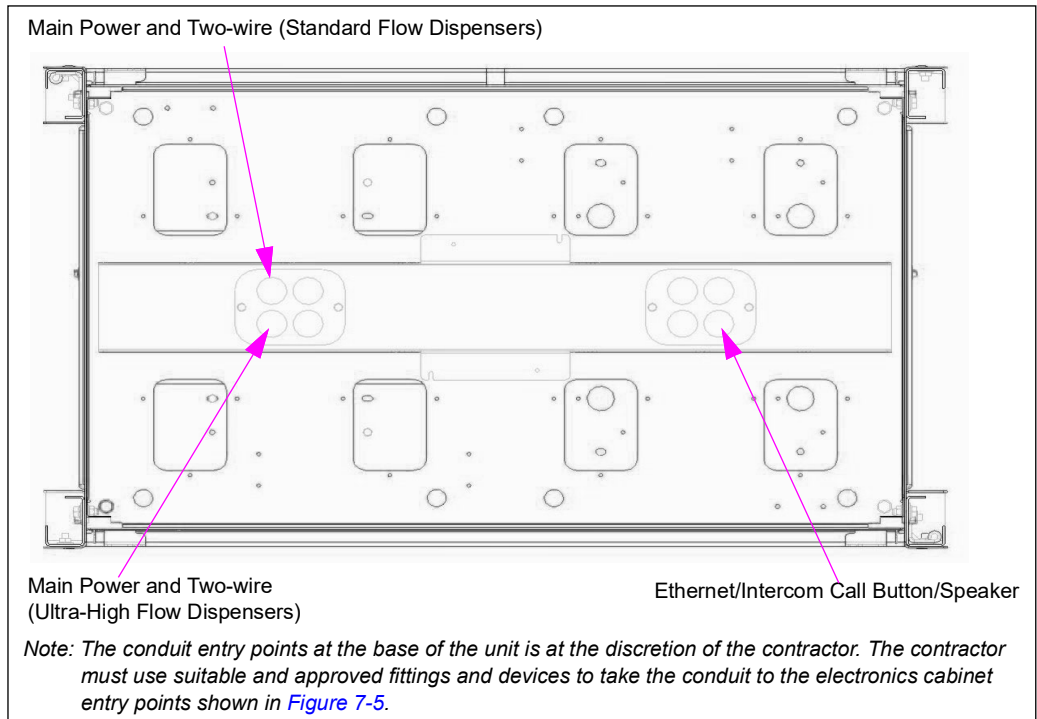

Figure 7-6: Typical Conduit Locations for Encore 900 (Entry from Side of Electronics Cabinet)

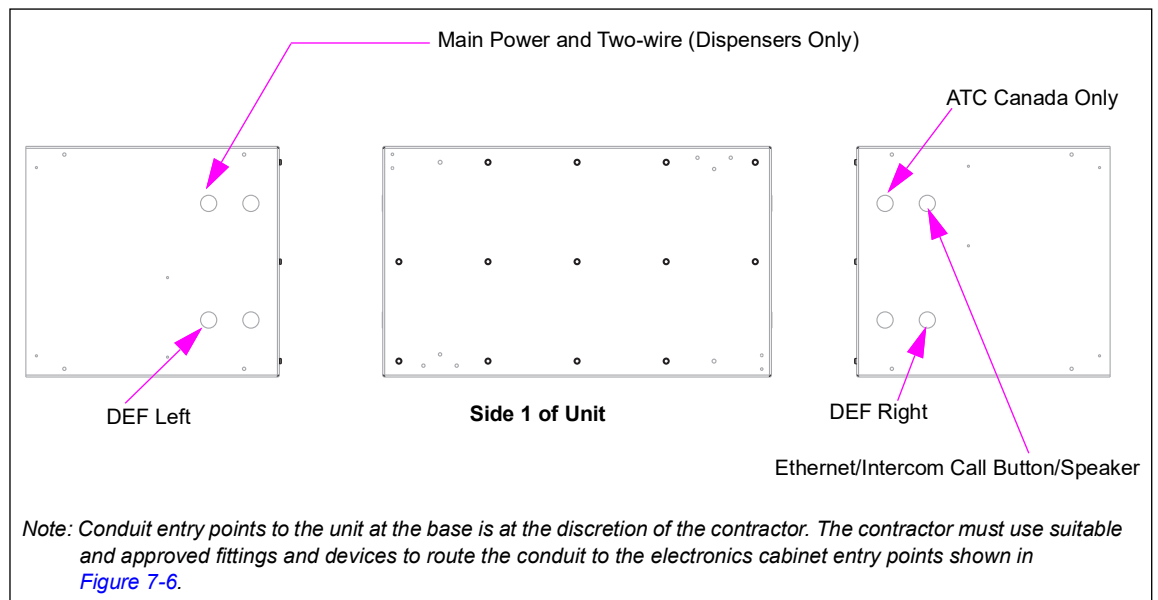
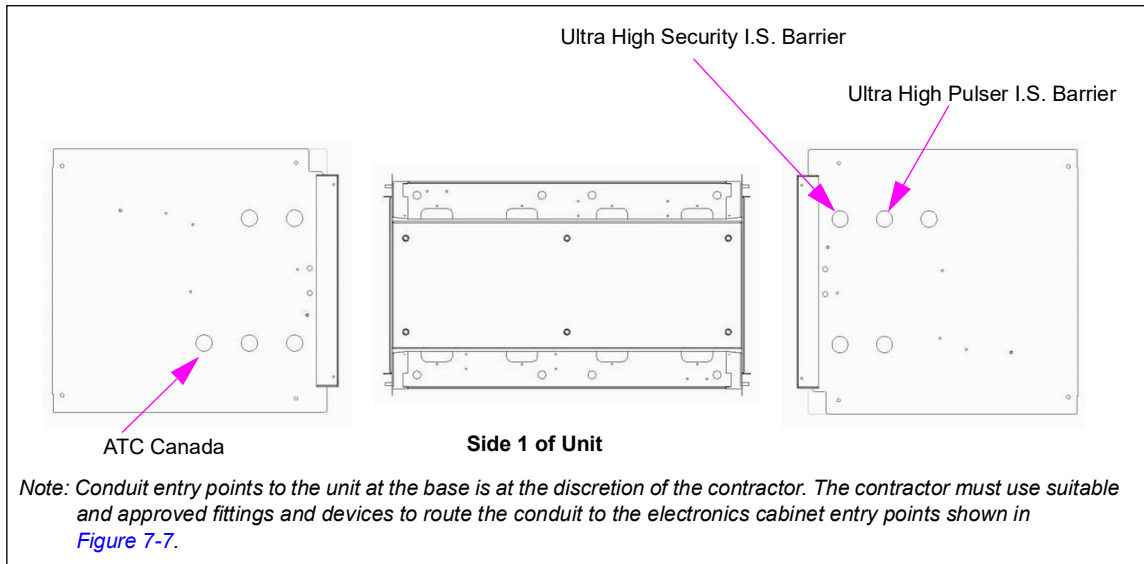

Figure 7-7: Typical Conduit Locations for Encore 900 (Entry from Side of Electronics Cabinet)



For conduit entry through the vapor barrier, the Encore unit contains eight sets of conduit knockout holes (four on the right and four on the left) for access to the electronics cabinet. Knock out the aligned (top and bottom air gap plate) 1-inch plugs for the required number and positions of contractor-supplied conduits (do not use conduits smaller than 1 inch with the conduit plate provided). For field installations, only two conduits at opposite corners can be installed per plate. Use the knockouts on the left (facing side 1) for all power and two-wire connections. Ethernet, International Forecourt Standards Forum (IFSF), speaker, intercom, and/or call button wiring must use knockouts on the right. For conduit entry through the side of the electronics cabinet, the Encore unit contains eight sets of conduit knockout holes (four on the right and four on the left) for access to the electronics cabinet. Knock out the 1-inch plugs for the required number and positions of contractor-supplied conduits.

Note: Do not use conduits smaller than 1-inch size.

Installing Conduit Through Vapor Barrier

Note: This is not required for units with factory-installed J-boxes.

To seal the air gaps and conduits in Encore units, proceed as follows:

- 1 Install the contractor-supplied 8 X 1 listed metal, rigid, threaded conduit through both the top and bottom air gap conduit plate holes according to the following procedure (see [Figure 7-8](#)).

Figure 7-8: Encore Conduit Sealing Plates

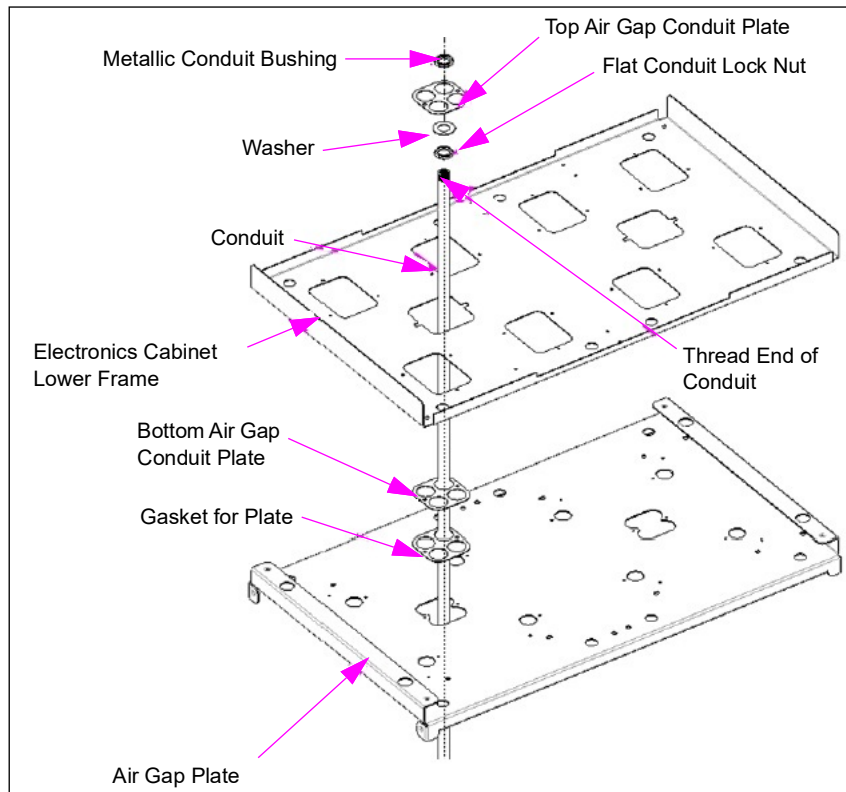

WARNING

Fuel vapors allowed to travel between the hydraulics and electronics cabinet presents the risk of fire or explosion. The resulting fire or explosion may lead to serious injury or death.

Never compromise the vapor barrier integrity by leaving out conduit plates or open holes (for example, by using conduit with a diameter smaller than 1-inch). For Canadian applications, do not leave out any gaskets.

A listed metallic conduit bushing must be installed at the top of the 8-inch conduit for mechanical retention of potting in the event of explosion.

Figure 7-9: Encore 900 Conduit Sealing Plates

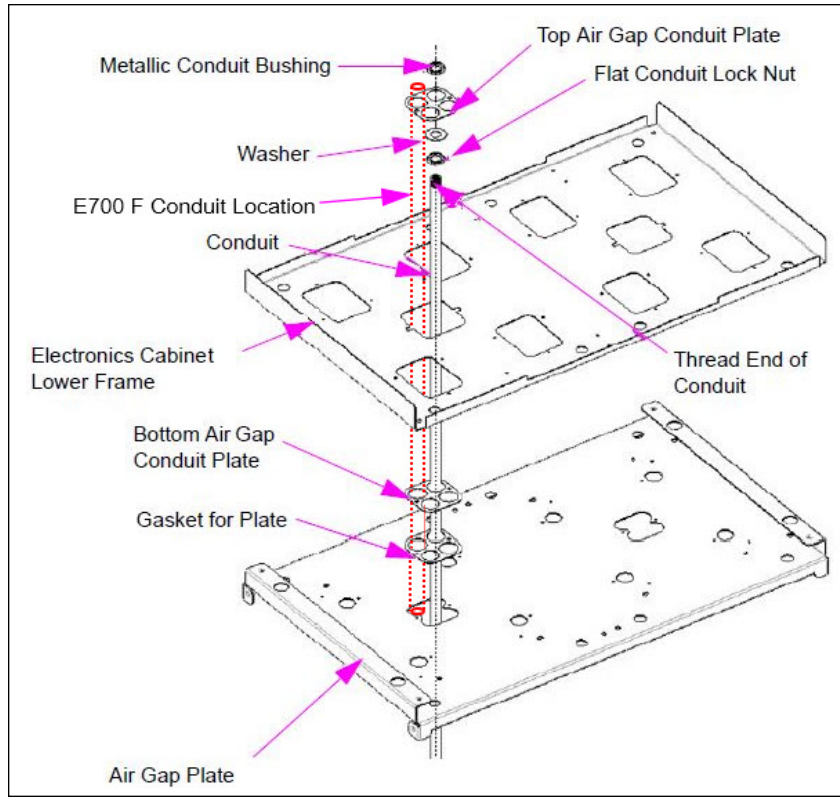

WARNING

Fuel vapors allowed to travel between the hydraulics and electronics cabinet presents the risk of fire or explosion. The resulting fire or explosion may lead to serious injury or death.

Never compromise the vapor barrier integrity by leaving out conduit plates or open holes (for example, by using conduit with a diameter smaller than 1-inch). For Canadian applications, do not leave out any gaskets.

A listed metallic conduit bushing must be installed at the top of the 8-inch conduit for mechanical retention of potting in the event of explosion.

- 2 From the electronics cabinet, remove two screws (not shown) and the upper conduit plate from the electronics cabinet lower frame. Retain all parts for reassembly.
- 3 Thread end of conduit about 1-1/2 inches from the end.
Note: The conduit can be installed to the top air gap conduit plate away from the unit.
- 4 Fasten the conduit to the conduit plate removed using a machined flat conduit lock nut and washer on the bottom of the plate. Fasten a listed, metallic conduit bushing on the top of the plate.
Note: Check with local electrical authority for need for metallic conduit grounding bushing.

- 5 Remove the two screws (not shown) and the bottom air gap conduit plate from the air gap plate. Retain all parts for reassembly.
Note: (Canada only) The gasket for the plate will come off with the plate. The gasket must be reinstalled with the plate.
- 6 Remove the aligned knockout plugs from the bottom air gap conduit plate as required, and reinstall the plate and screws.
- 7 From the electronics cabinet, slide the conduit down through the knockout in the air gap plate.
- 8 Reinstall the top air gap conduit plate onto the electronics cabinet lower frame using screws to secure the conduit in place.

Installing Conduit Through Side of Electronics Cabinet

Figure 7-10: Conduit Routing Through Side Column into Electronics Cabinet

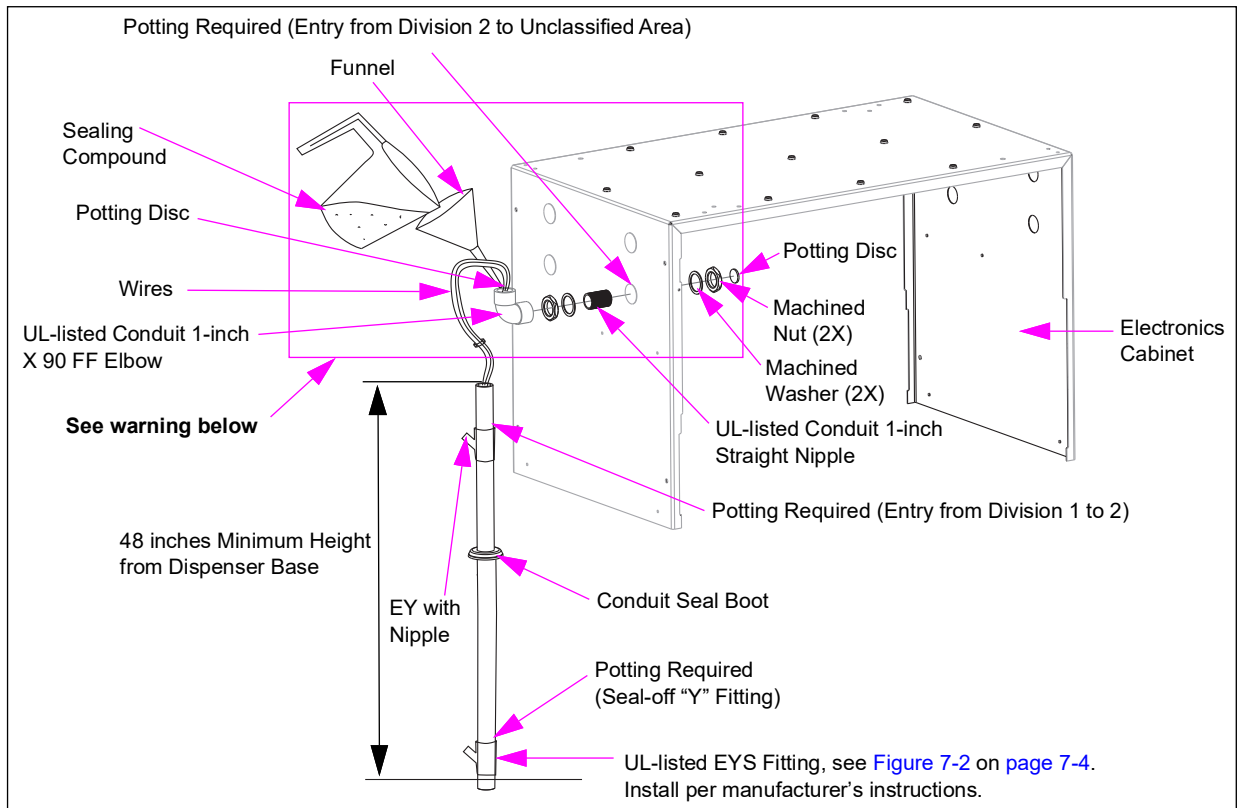

WARNING

Installation using this method requires Gilbarco Installation Kit (M07838K001). Failure to use the kit will result in damage or injury.

Figure 7-11: Conduits and Potting Discs

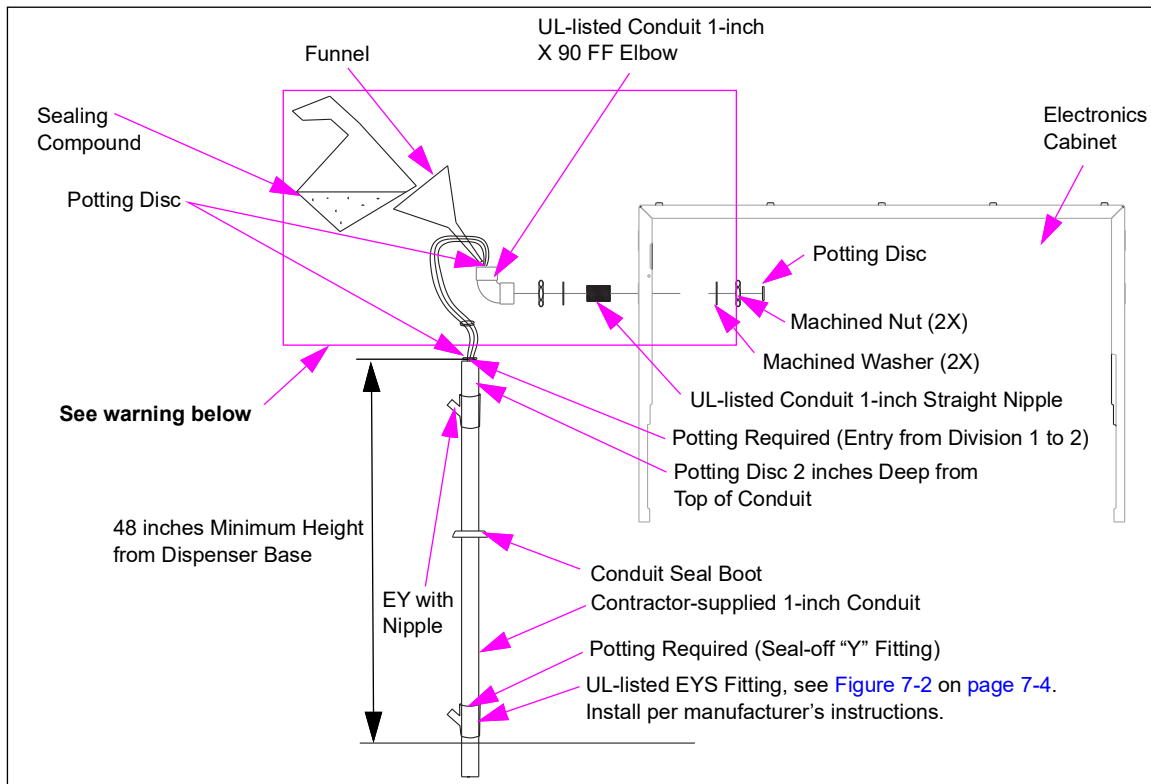

WARNING

Installation using this method requires Gilbarco Installation Kit (M07838K001). Failure to use the kit will result in damage or injury.

- Notes:*
- 1) Conduit seal boots and liquid deflectors are not used on all dispensers.
 - 2) Use UL-listed metallic conduit bushing for wire protection.
 - 3) On dispensers without the factory-installed J-box, run conduits for:
 - The power and two-wire communications.
 - Speakers and call buttons (if required), and
 - SMART Connect™ (if required) through the side column into the electronics cabinet as shown in [Figure 7-10](#) on [page 7-13](#).

Installing Wiring

Notes: 1) The wiring must be gas and oil-resistant, color-coded, or tagged for identification purposes, and rated for 300 volts or higher. Data wires for new installations must be a twisted-pair (unshielded) with 10 to 12 twists per foot.

2) For more information, refer to the following documents:

- FE-353 Field Wiring Diagram Encore 550 Dispensers, 120/240 VAC
- FE-363 Field Wiring Diagram Encore 500/700 (M07555 Power Supply Only)
- FE-364 Field Wiring Diagram for Encore 300
- MDE-3802 Encore and Eclipse Site Preparation Manual

Operating Environment

Environment	Range
Relative humidity	20 to 95% (non-condensing)
Minimum outside ambient temperature	-22 °F (-30 °C)
Maximum outside ambient temperature	104 °F (40 °C)*

*Electronics have been evaluated and are rated for use at a maximum of 131 °F (55 °C) outside ambient temperature.

To ensure proper unit performance, operation under severe environmental conditions may require special options, such as card reader heaters and so on.

Operating Environment - Special Considerations for DEF Dispensers

CAUTION

DEF freezes at about 11 °F (-11.5 °C). Power to the dispenser and heater must always remain ON in cold weather. If power is lost and the temperature drops below this point within the DEF cabinet, the system must be inspected for freeze damage before restart.

Load Table Reference Locations

Model	Unit	Field Wiring Diagram
Encore 300 Series	All products	FE-364
Encore 500	All products	FE-363
Encore 550	All products	FE-353
Encore 700 S	All products	FE-353
Encore 900	All products	FE-353

Heater Load Table

10.4" Color Display Heater Option Load*

6.6 A @ 120 VAC 60 Hz

*The heater will only cycle when it is cold.

Load Table Reference Locations - DEF Dispensers

This section is applicable to DEF only dispensers (standalone DEF dispensers). This is not applicable to DEF+1 dispensers. A separate breaker is required for the heater (6.6 A @ 120 VAC 60 Hz). For more information, refer to *FE-363 Field Wiring Diagram Encore 500/700 (M07555 Power Supply Only)*.

Note: Heaters are thermostatically controlled and will cycle between on and off during cold weather to maintain a minimum cabinet temperature.

Wiring External to Dispenser

To install the wiring external to the dispenser, proceed as follows:

- 1 Pull the wiring through the stub up and sealing fitting.

Notes: 1) Ensure that enough extra wire length (minimum of 5 feet or 1.5 meters) is provided to make the run to the stub up location at the bottom of the electronics cabinet.

2) Remember that you may be routing the conduit over to come up at the stub up to the electronics cabinet. Depending on which end of the unit the stub up is on, you may be routing across the entire unit length.

- 2 For the side column conduit entry, install a short 2-inch threaded nipple into the top of the sealing fitting.
- 3 For the side column conduit entry, install a capped pulling elbow. The use of a Killark Y-3 fitting is recommended (see [Figure 7-2](#) on [page 7-4](#)).
- 4 The remaining conduit must be made up to match the installation layout for the unit at the site. A list of the most common procedures for conduit entry to the right when facing side 1 is given below.
 - The length of the conduit must extend straight out from the capped Y fitting or pulling elbow.
 - For the side column entry, the conduit must then be turned by 90-degree angle, vertical under the air gap plate knock out.
 - Use the required air gap plate knock out. Do not knock out any knock out plugs that will not be used as an opening for conduit.
 - All the conduits that enter into the electronics cabinet must be potted.
 - At least 1 inch of conduit must extend above the bottom shelf of the electronics cabinet.
 - Complete the conduit run with a conduit nut on the inside of the cabinet.
 - Pull all wires properly through the conduit. Finalize the procedure by potting the conduit end.
 - Allow 18 inches of wire in the electronics cabinet for field connections. The wire must be trimmed as required on field connection.
 - All the conduits and fittings must be listed and suitable for use in class 1, division 1 hazardous locations from the seal off fitting to the potted conduit.

Figure 7-12: Wires Routing Through Conduit

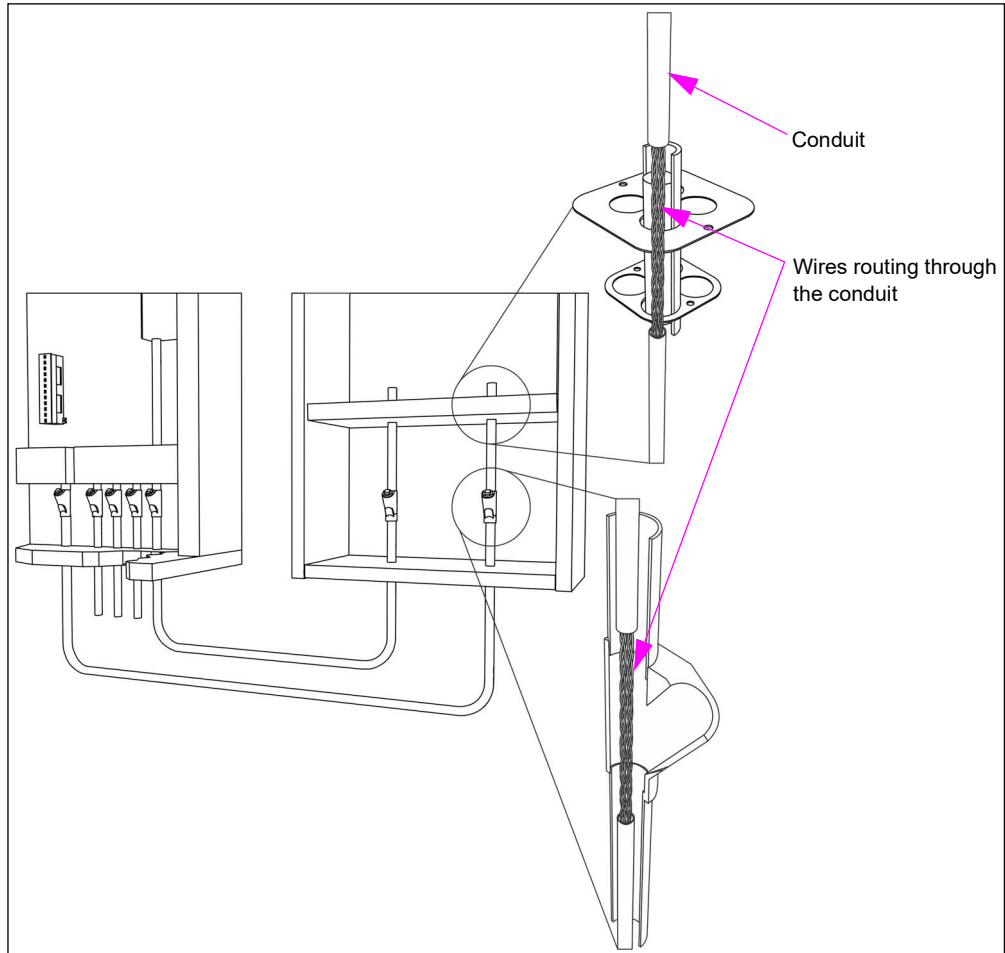

Testing New Field Wiring

⚠ WARNING



Sparks can ignite fuel/vapors.

Fire/explosion can result in severe injury or death.

Use caution when testing wires. Do not test when exposed fuel and vapors are present.



Only use a Megger® tester on new field wiring.

For existing wiring, use a digital multimeter to test for continuity/resistance.

Test the insulation of the new wiring from the station and to the electronics cabinet before connecting the wires. Refer to the warning above. This checks for damage that can occur while pulling wires through the conduit.

To test the new field wiring, proceed as follows:

- 1 Ensure that wires are disconnected at both ends. If you do not disconnect wires at both ends, you can damage the pump/dispenser electronics.
- 2 Test the conduit wiring ends by using an insulation/Megger tester.

- 3 Connect one tester lead to the wire under test.
- 4 Connect the other tester lead to the ground.
- 5 Measure the resistance. Follow the test equipment manufacturer's instructions. Insulation resistance of more than 50 megohms is satisfactory. Check the local authority requirements.
- 6 Repeat steps 1 (on [page 7-17](#)) to 5 for all the new wires.
- 7 Repeat the test between all the new wires.
- 8 When all wiring tests are complete, the wiring may be potted.

Wiring Internal to Dispenser

To install the wiring internal to the dispenser, proceed as follows:

Running Wire to Electronics Cabinet (Without J-box)

For units without the factory-installed J-boxes, the technician will have to make all wiring connections in the electronics cabinet. For units with J-boxes, connections will be made in the J-box. The pump field wiring connections are made in the main J-box. Canadian applications require seals at certain air gap locations. These seals are not required for U.S. applications and most other locations.

Pull the wiring to the electronics cabinet for non-factory-installed J-box units. Do not complete field wiring at this time.

- 1 Feed wires through all contractor-supplied fittings and the 8-inch installed conduit to electronics cabinet.
Note: All fittings must be listed and suitable for use in a class 1, division 1 hazardous location. It is recommended that the contractor use a conduit elbow or pull the elbow to connect to the 8-inch conduit to allow easy potting of the conduit (see [Figure 7-20](#) on [page 7-25](#)).
- 2 Install the fiber potting dam material at the bottom of the 8-inch conduit to a thickness of 3/4 inches. Refer to "[Potting Conduits](#)" on [page 7-27](#). Do not pot at this point in time.
Note: Use only the fiber potting dam material specified by the potting compound manufacturer, which conforms to the requirements of NFPA 70. Examples of permissible materials are Killark type "PF" and/or Crouse-Hinds® CHICO X packing fiber. A small screwdriver may be used to press the fiber dam material around and between wires to prevent compound or vapor leak-by. Follow the sealing compound manufacturer's directions for the type of fiber that is to be used.
- 3 Tighten all the conduit unions and fittings.
Note: Not more than 18 inches of wire must be left above the top of the conduit. All excess wire length must be trimmed and wires routed away from sharp edges.

Wiring Pump (Self-contained Unit)

For dispenser wiring, refer to “[J-box and J-box Conduit Installations](#)” on [page 7-5](#).

Preparing Field Wiring

Self-contained factory units have the factory-installed J-box on side 1 of unit. Field connections are through the 1-inch conduit supplied, which starts on side 2 (see [Figure 7-13](#)).

Figure 7-13: J-box Conduit Layout

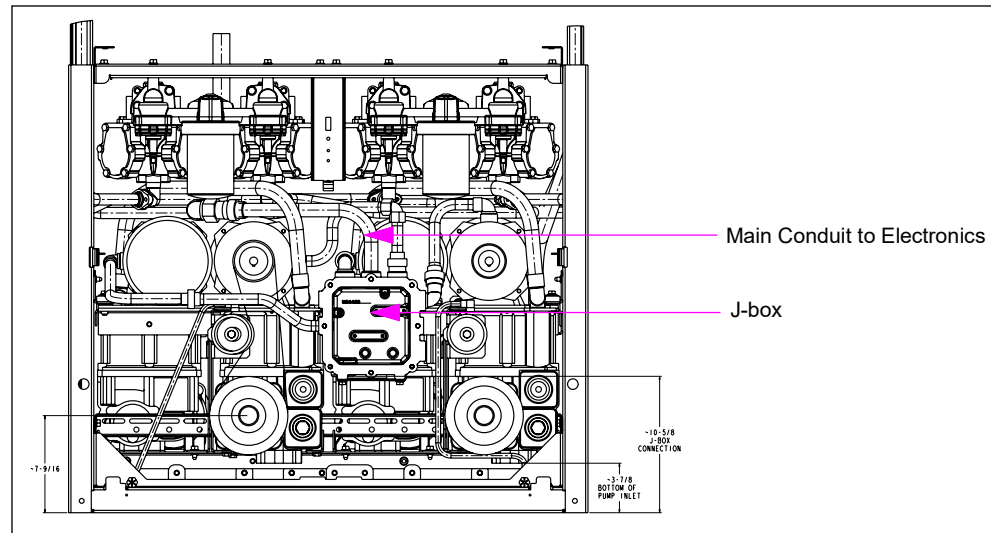

To prepare for the field wiring, proceed as follows:

- 1 Open the CIM door on side 1 of the unit. For instructions, refer to *MDE-3804 Encore and Eclipse Start-up/Service Manual*.
Note: Side 1 contains a J-box.
- 2 Remove the support brace to gain access to the J-box cover. Refer to “[Wiring Pump \(Self-contained Unit\)](#)” on [page 7-19](#). Save the hardware for reinstallation.
- 3 Remove the box cover and retain for reassembly.
Note: For Encore units that are replacing older units, if the existing wire is too short to reach the installed J-box and a splice must be made, the contractor must provide and use a class 1 division 1 explosion-proof J-box to make connections according to the code. Refer to “[Before Mounting Unit on Fuel Island](#)” on [page 4-9](#).
- 4 For all units, verify if a seal-off Y fitting has been installed and sealed as a first connection where the conduit leaves the ground. This fitting must be in place and sealed before proceeding further. Refer to *MDE-3802 Encore and Eclipse Site Preparation Manual*. Install the adaptive 1-inch metal conduit and union to the J-box conduit.
- 5 If the unit requires a call button and conduit, read and understand “[Encore Elevation Diagram \(Encore 550 with SMART Meter\)](#)” on [page A-21](#) before proceeding. If the unit contains a lighted canopy, read and understand “[Lighted Canopy Conduit and Wiring Options](#)” on [page 7-25](#) before proceeding.
- 6 If removed earlier, reinstall the vertical support brace to gain access to the J-box. The support brace is not optional.

Wiring Ultra-Hi Dispenser

Depending on the application, Ultra-Hi units require that a specific set of cables be installed. These cables are used to intercept the existing cables and provide connection points from the master and/or satellite units.

Preparing Field Wiring

To prepare for the field wiring, proceed as follows:

- 1 Open the CIM door on side 1 of the unit. For instructions, refer to *MDE-3804 Encore and Eclipse Start-up/Service Manual*.
Note: Side 1 has electronics module access to field connections, boards, and wiring.
- 2 For units with the J-box installed, remove the box cover and save for reassembly.
Note: For Encore units that are replacing older units, if the existing wire is too short to reach the installed J-box and a splice must be made, the contractor must provide and use a class 1 division 1 explosion-proof J-box to make connections according to the code. Refer to “Before Mounting Unit on Fuel Island” on page 4-9.

Following table lists the information on cables that are used for specific applications, refer to “Ultra-Hi Intercept Cables”. For more information on connections, refer to *FE-364 Field Wiring Diagram for Encore 300*.

Description	Part Number	Application	Illustration in Figure
Main AC	M02338	All Ultra-Hi Master Units	Figure 7-14 on page 7-21
Valve Intercept	M02372	Master of Combo Unit - for Satellite Light Only	Figure 7-16 on page 7-22
Combo Neutral	M02384	Satellite Side of Combo Unit, Satellite	Figure 7-17 on page 7-22
Transformer Subassembly	M02370	Master of Combo Unit ~ OR ~ Encore Satellite - for Satellite Light Only ~ OR ~ Legacy Satellite	Figure 7-15 on page 7-21
Combo Pump Handle	M02385A001	Encore Satellite, Combo	Figure 7-18 on page 7-22
Combo 9 VAC	M02386A001	Encore Satellite, Combo	Figure 7-19 on page 7-22

- 3 Some cable configurations require that one of the existing connectors be cut off the wires. This allows the wire to be secured to other wires with wire nuts, refer to the field wiring diagrams and illustrations noted in the table above.

Ultra-Hi Intercept Cables

Following figures (see [Figure 7-14](#) through [Figure 7-19](#) on [page 7-22](#)) contain a description, the associated cable block diagram, and the device with which the cable is used.

Figure 7-14: Main AC Cable (M02338A001)

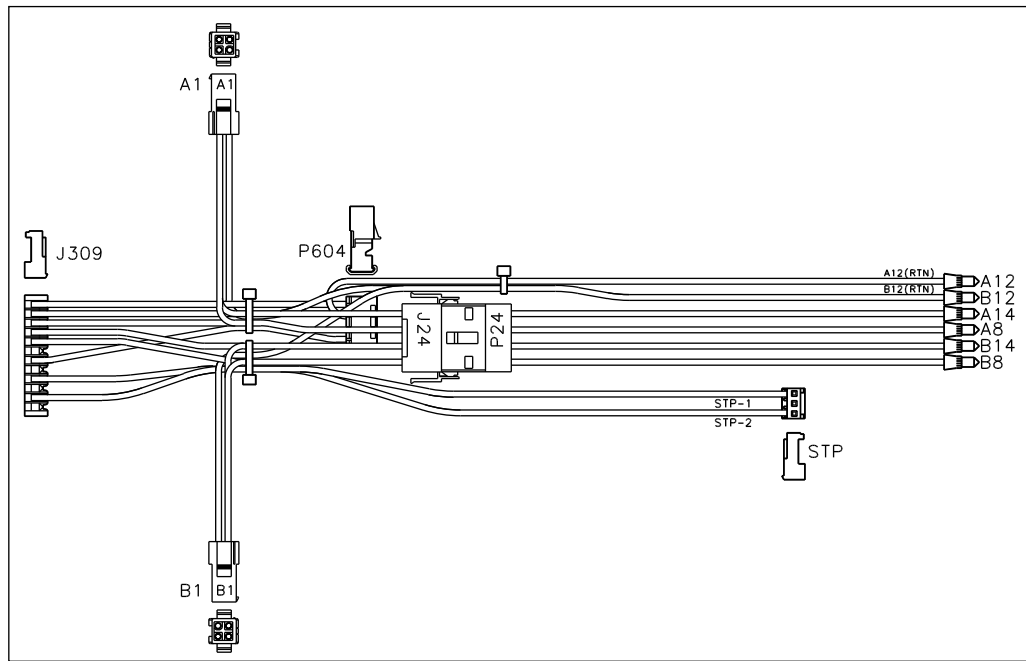

Figure 7-15: Transformer Subassembly (M02370A001)

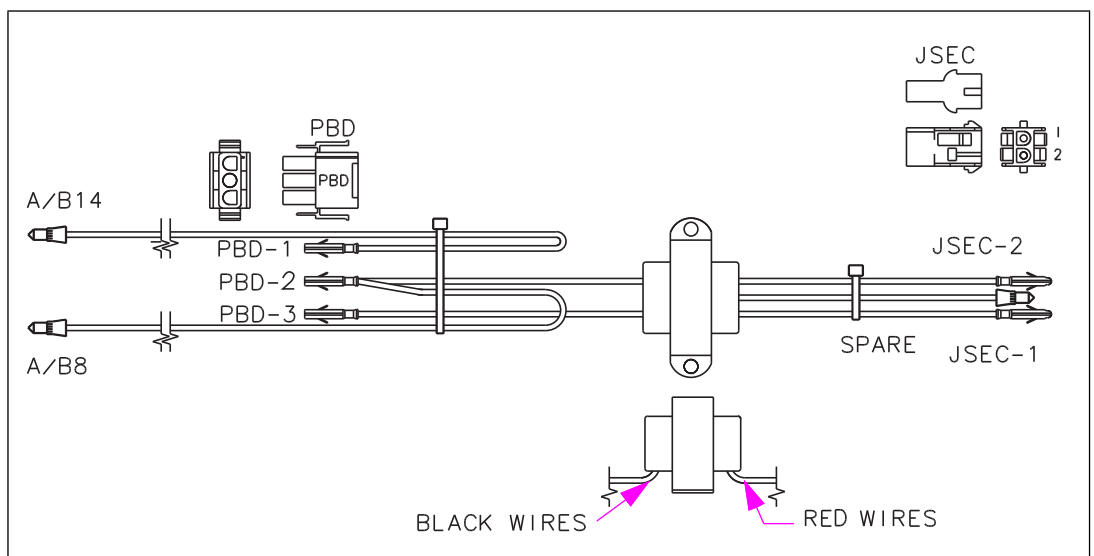

Figure 7-16: Valve Interceptor Cable (M15276A001)

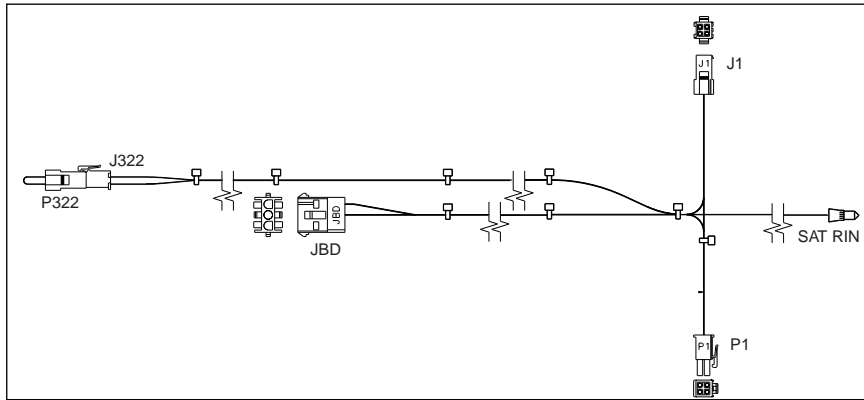

Figure 7-17: Combo Neutral Cable (M02384A001)

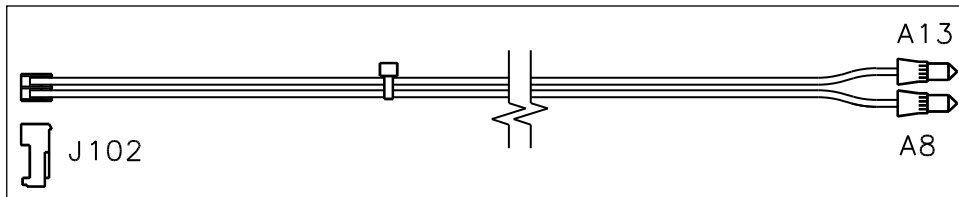

Figure 7-18: Combo Pump Handle Cable (M02385A001)

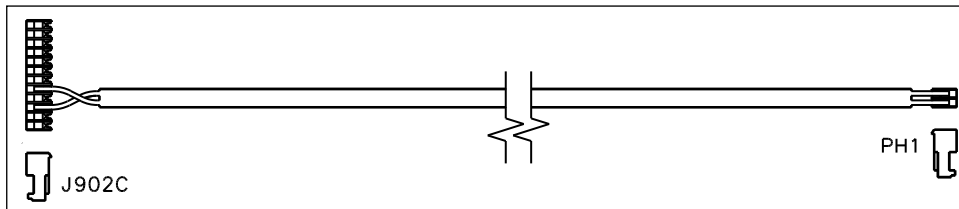
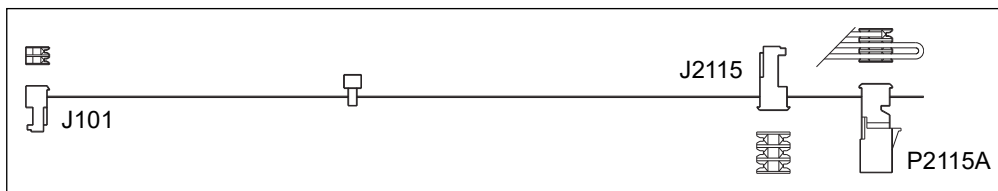

Figure 7-19: Call Interface Power Cable (M02802A001)



Completing Field Wiring

In older units with a contractor-supplied box or without a J-box, the wiring is connected to spring-loaded terminals in the electronics cabinet. New units are wired using wire nuts. A small insulated shank screwdriver may be used to open the spring-loaded terminal by pressing down on the spring through the slot provided, but care must be exercised to prevent damage.

To complete the field wiring, proceed as follows:

- 1 Remove the cover of the J-box for models so equipped.
- 2 For units with the factory-installed J-boxes, make the connections in the J-box. For units with contractor-supplied J-boxes, connect wiring in both the electronics cabinet and J-box. For units without J-boxes, make connections in the electronics cabinet according to the *FE-363 Field Wiring Diagram Encore 500/700 (M07555 Power Supply Only)*, and *FE-364 Field Wiring Diagram for Encore 300*. Do not disturb the sealing compound around the wires in the existing conduit. Do not disturb the factory wiring in the electronics cabinet.
- 3 For units with J-boxes, use pipe plugs [refer to *FE-363 Field Wiring Diagram Encore 500/700 (M07555 Power Supply Only)*, and *FE-364 Field Wiring Diagram Encore 300*] to seal the unused openings in all J-boxes. Replace the cover on the boxes.
- 4 Double-check all wiring connections for wire nuts, lugs, caps, and so on. Reinstall the J-box cover. Ensure that you do not pinch the wires and use all J-box bolts.
- 5 Ensure that all the conduits entering the electronics cabinet are properly potted.
- 6 On non-SMART Meter applications, reinstall the vertical support brace that was removed to gain access to the J-box.
- 7 Replace the lower doors and close the doors to the electronics cabinet.

Optional Conduits and Wiring

To install a call button/speaker conduit, proceed as follows:

Installing Call Button/Speaker Conduit

IMPORTANT INFORMATION

- Conduit for call button/speaker wiring must be installed in accordance with all instructions related to the conduit found in *MDE-3802 Encore and Eclipse Site Preparation Manual*, this manual, and appropriate unit specific addenda. Also, consult the equipment manufacturer regarding considerations for equipment tied to call buttons.
- Call button/speaker circuits must be class 2 NEC wired. Refer to NEC article 725.136B (in the 2011 Edition) and the "Wiring" section in *MDE-3802 Encore and Eclipse Site Preparation Manual*. All requirements for speaker wiring are also applicable to call button wiring, and all general procedures and requirements for wiring are applicable.

For Encore units, conduits may be run into the electronics cabinet without the use of a J-box. Wherever a J-box is required, (for example, wire connections are required), the contractor must provide an appropriate class 1 division 1 explosion-proof junction. For sizing and procedures, refer to [“Connecting to ISD Vapor Flow Meter”](#) on [page 7-29](#) and mandatory J-box installation requirements in step 4 of [“J-box and J-box Conduit Installations”](#) on [page 7-5](#).

The conduit run for any purpose, including call button, on all units must have a seal-off ‘Y’ fitting installed as a first connection where the conduit leaves the ground. For mandatory requirements, refer to the sections “Conduit” and “Sealing Y” fittings in *MDE-3802 Encore and Eclipse Site Preparation Manual*.

 **WARNING**

Bottom plate of the electronics cabinet and the top plate of the hydraulics cabinet are separated in accordance with safety requirements.

 Loss of integrity at plate penetrations or improper installation of parts can allow fuel vapors to ignite. Resulting fire and/or explosion can lead to serious injury or death.

 Running the conduit through the air gap requires strict compliance with procedures outlined in this manual and unit specific addenda. Only listed rigid metal 1-inch conduit may be installed in any unit between hydraulics and electronics cabinets. No unused holes in air gap plates, open spaces between conduit and plates, or unsealed conduit penetrations can be present following installation.

All procedures and requirements in [“Completing Field Wiring”](#) on [page 7-23](#) apply with equal force to call button/speaker conduit installations. This includes the mandatory use of the contractor-provided 1 X 8-inch conduit stub for any penetration of air gap, and potting of conduit, as detailed in the section. Refer to [“Encore Foundation Diagrams: 2 to 9 \(Dispensers with Piston Meters\)”](#) on [page A-12](#) showing the location of the penetration point for the call button conduit.

Note: The conduit must be potted irrespective of whether the J-box is installed or not.

Lighted Canopy Conduit and Wiring Options

The Canopy wiring must be installed in accordance with NFPA 70, UL 87, and canopy manufacturer's instructions. Read the entire manual before you begin the conduit installation.

Figure 7-20: Lighted Canopy Conduit and Wiring

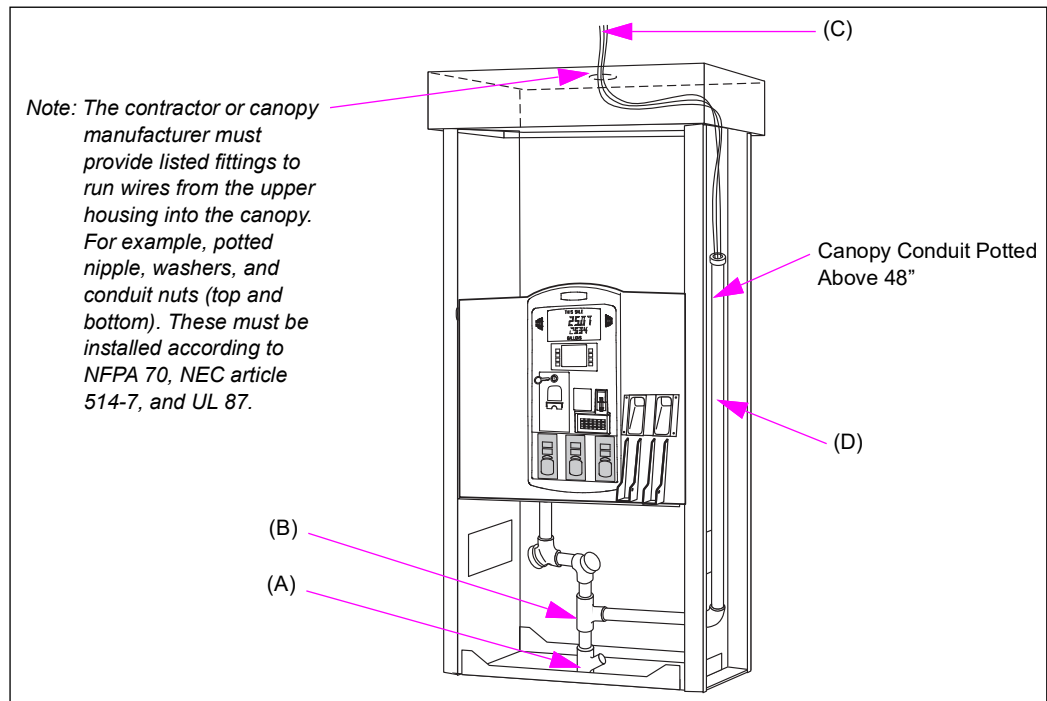

To wire the lighted canopy conduit, proceed as follows:

- 1 Before you proceed, ensure that the seal-off Y fitting (A) has been installed according to NEC article 514-7, this manual, and the fitting manufacturer's instructions. Fitting must be potted to complete the installation.
- 2 Using only listed rigid conduit and explosion proof fittings, conduit tee (B) or class 1, division 1 hazardous location rated J-box (option not shown, refer to *MDE-3802 Encore and Eclipse Site Preparation Manual* for references on J-box sizing) may be installed above the seal-off fitting.
- 3 The tee or J-box allows branch-off of power wires for the canopy.
- 4 The canopy vertical conduit (D) is run inside the side column as shown. The conduit **MUST** be potted at a height of 48 inches or higher, with potting material poured to a depth equal to or greater than the trade size of the conduit, and in accordance with NFPA 70 and NEC article 514-7. For details, refer to the potting compound manufacturer's instructions.
- 5 A UL-listed metallic conduit bushing **MUST** be slipped over wires and installed at the top of the conduit after potting.

- 6 Run the canopy wires (C) up the column and across the upper housing to knockout in the center of the top cover, protecting the wiring from sheet metal edges.
- 7 The lighted canopy must be installed onto the unit in accordance with UL and NFPA requirements. This will require, but not be limited to providing a potted nipple for the wires going from the upper housing into the canopy, and the appropriate listed nuts and washers.

Potting Conduit Stubs

Before potting, ensure that all conduits have been installed, wires pulled, and all wires are tested. All conduits entering the electronics cabinet on dispensers or pumps must be potted. Any contractor-supplied conduits entering the electronics cabinet must be potted.

Potting up to Unit

Fill the sealing fitting with potting compound to seal the pathway of the field wiring to the station building. Refer to “[Completing Field Wiring](#)” on [page 7-23](#) or see [Figure 7-21](#) on [page 7-27](#).

Potting Within Unit

To pot within unit, proceed as follows:

Potting to Electronics Cabinet Through Vapor Barrier

In all Encore units, for conduit entry through the vapor barrier, each of the contractor-provided 8 X 1-inch conduits entering and exiting the electronics cabinet must be sealed with a sealing compound through the full length of the conduit. This fill-to-length is mandatory according to UL requirements. Refer to “[Important Safety Information](#)” on [page 2-1](#).

To pot the conduit, proceed as follows:

- 1 Mix the compound in a clean vessel according to the compound manufacturer’s instructions. Mix only as much potting compound as can be used before the compound hardens.
- 2 Using a funnel, carefully pour the sealing compound into the conduit from the top until the compound is within 1/4 inch from the top of the conduit (see [Figure 7-21](#) on [page 7-27](#)).
Note: Ensure that you pour slowly to prevent air bubbles from forming in the compound and wires around.
- 3 Immediately clean the spilt compound from the conduit threads and cabinet surfaces.

- 4 Install the UL-listed metallic conduit bushing.
Note: Check with local electrical authority for need for metallic conduit grounding bushing.

Figure 7-21: Potting Conduits

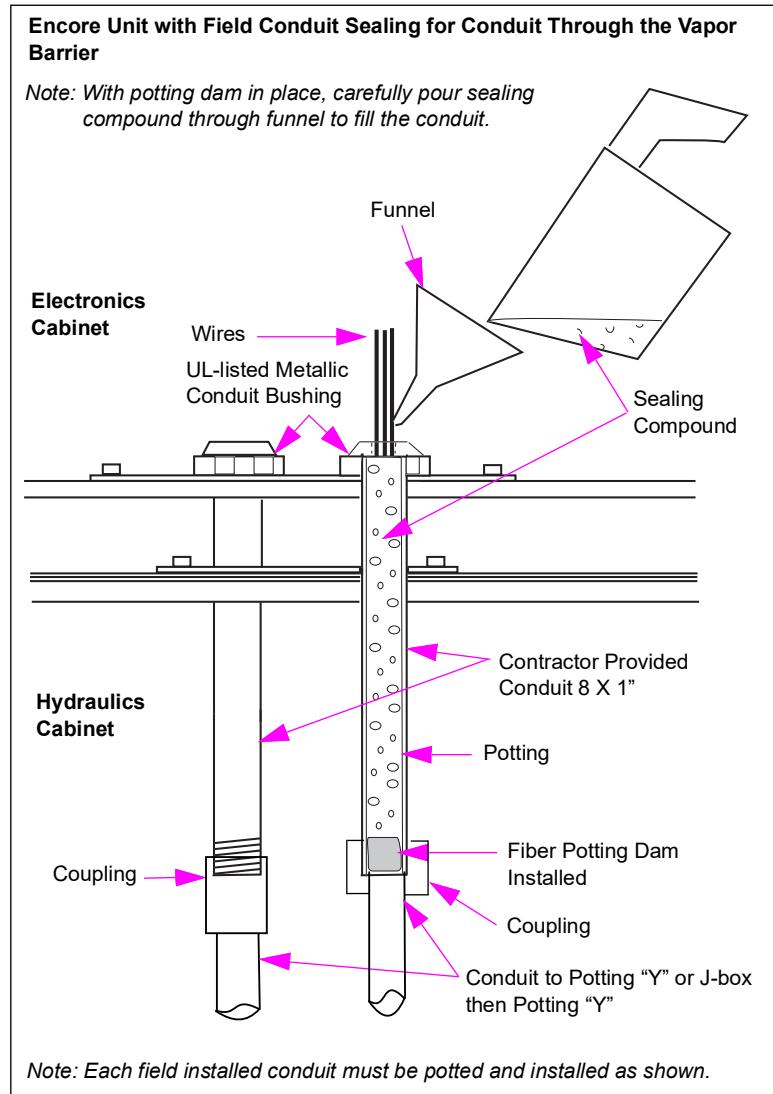

WARNING

Fuel vapors allowed to travel between the hydraulics and electronics cabinets presents the risk of fire or explosion. The resulting fire or explosion may lead to serious injury or death.

Never compromise the vapor barrier integrity by leaving out conduit plates or open holes (for example, using conduit smaller than 1 inch in diameter). For Canadian applications, do not leave out any gaskets.

The UL-listed metallic conduit nut must be installed at the top of the 8-inch conduit for mechanical retention of potting in the event of explosion.

Potting Through Side of Electronics Cabinet

The rising conduits and side column entry components through the side cabinet must be potted as shown in [Figure 7-22](#). The conduit entry must also use seal washers, nuts, and a capped bushing. M07838K001 Kit [including *MDE-4701 Side Conduit Entry Hardware Kit (M07838K001) Installation Guide for Encore Units*] supplies the parts used for such conduit entry plus additional instructions to ensure proper installation. One kit is required per conduit. Knockout in the column is sized for 1-inch conduit. Do not use smaller conduits. Run power and communication wires to the left side of the unit when facing side 1. Run the speaker and other wire conduit to the right side.

Figure 7-22: Conduit Routing Through Side Column into Electronics Cabinet

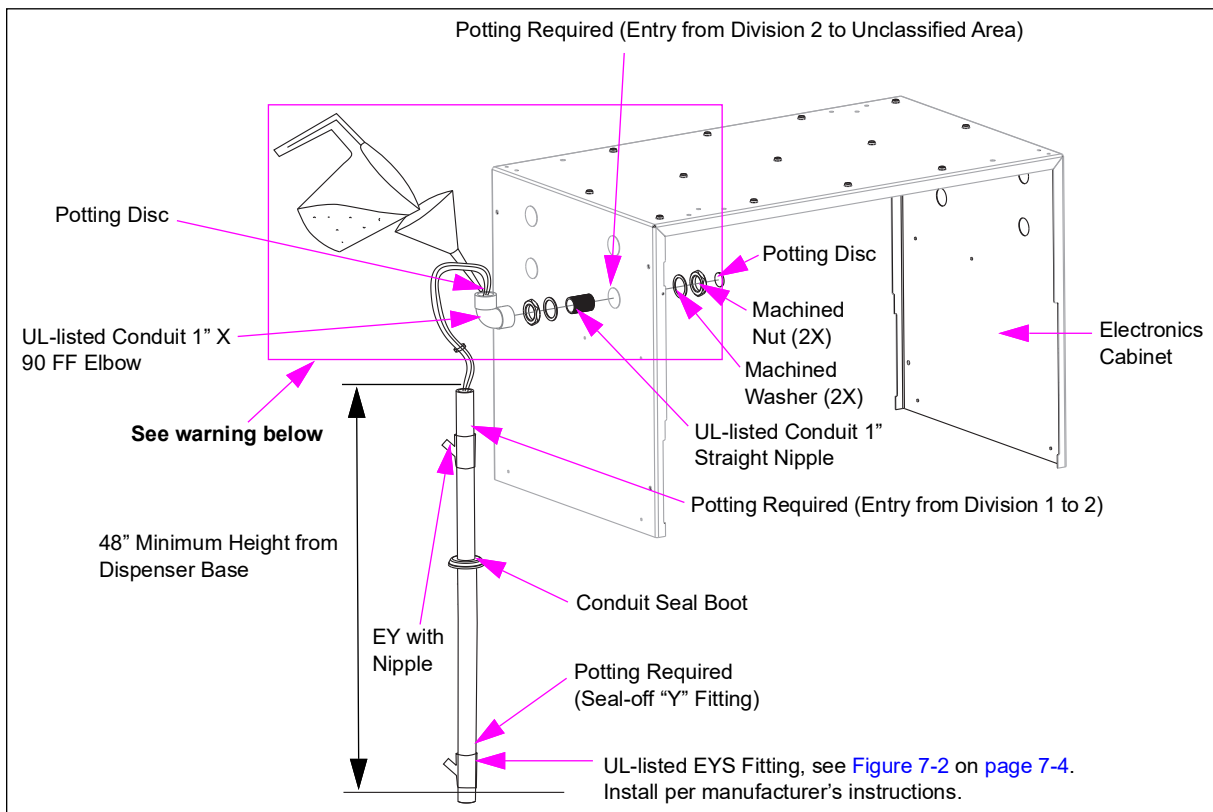

WARNING

Installation using this method requires Gilbarco Installation Kit (M07838K001). Failure to use the kit will result in damage or injury.

Notes: 1) When pulling wire, allow 8 feet of wiring above the ground to make the side electronics cabinet entry wiring connections.

2) A seal-off is required where the conduit exits the ground into the cabinet. A seal-off is also required where the conduit enters the side of the electronics cabinet.

Connecting to ISD Vapor Flow Meter

At Dispensing Unit

The vapor flow meter is part of an ISD system that measures the amount of vapor returning to the UST. The wiring for this device is intrinsically safe and must be run in a separate conduit to the Veeder-Root monitoring equipment or as per other allowable Veeder-Root recommendations. The conduit must be potted where it enters and leaves any designated hazardous zones. The potting requirements for hazardous zones must be followed so that fuel vapors do not migrate to other areas. The ISD vapor flow meter wiring terminates at the Tank Level Sensor (TLS) console. The flow meter is in-line and near the vapor return shear valve in the hydraulic area of the unit. Do not create any liquid flow traps. For more information on liquid traps, see [Figure 6-9](#) on [page 6-12](#).

Figure 7-23: ISD Vapor Flow Meter

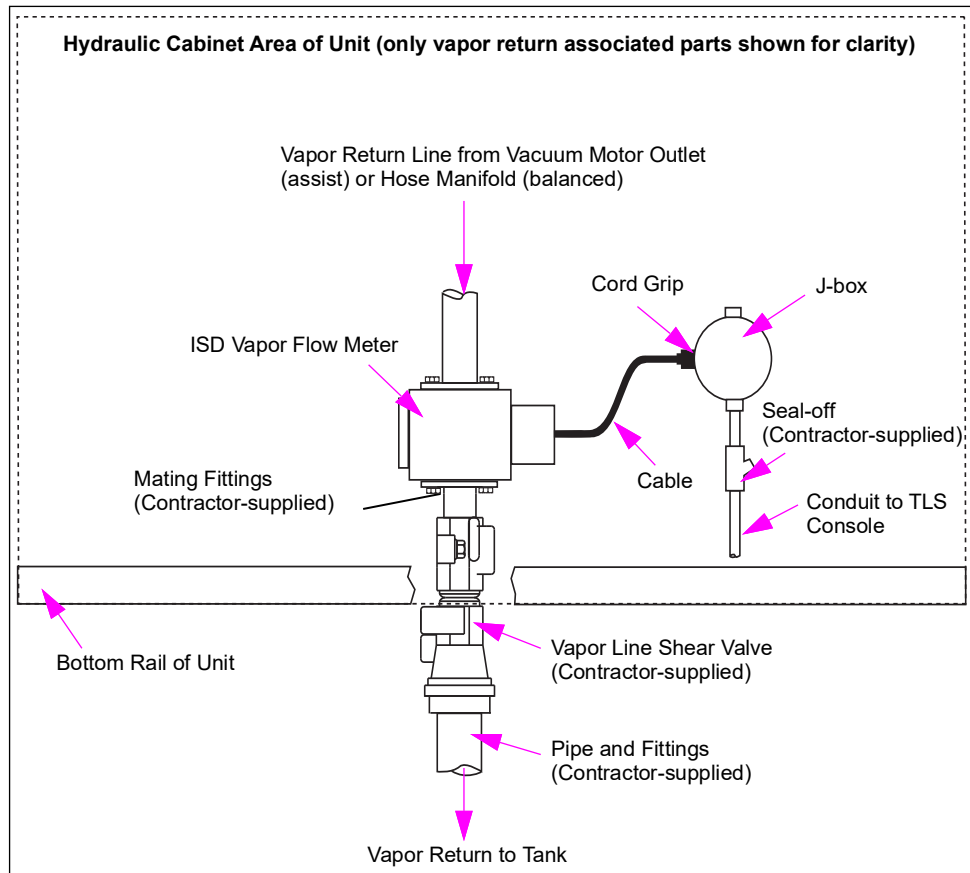

Epoxy Sealing

Sealing of wiring connections is required to ensure proper performance of intrinsically safe devices where minor corrosion can affect communication to the device.

⚠ CAUTION

 Epoxy sealant is irritating to the eyes, respiratory system, and skin. It can cause an allergic skin reaction. It contains epoxy resin and cycloaliphatic epoxy-carboxylate.

 Precautions: Wear suitable protective clothing, gloves, eye, and face protection. Use only in well ventilated areas. Wash thoroughly before eating, drinking, or smoking.

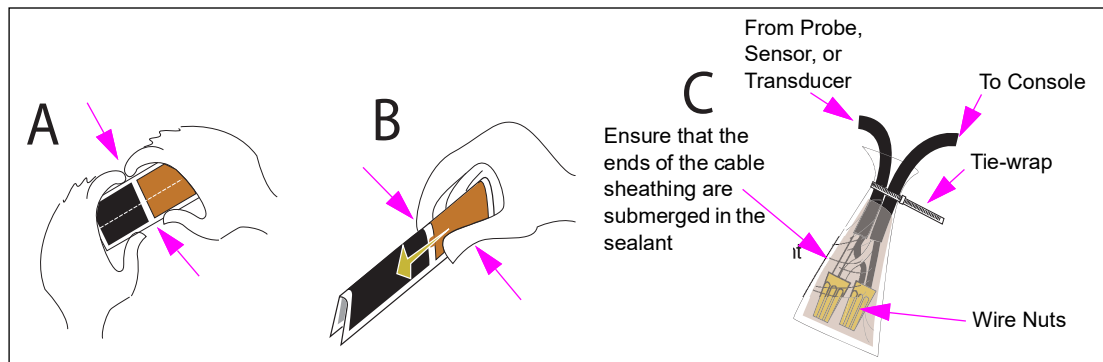

Figure 7-24: Epoxy Sealing Field Wiring



Note: When the temperature is below 50 °F (10 °C), keep the resin in a warm place before mixing (for example, in an inside pocket next to the body).

To seal the wire nuts with an epoxy sealant, proceed as follows:

- 1 Open the epoxy sealant package, and remove the resin pack.
- 2 Hold the resin pack as shown in A (see [Figure 7-24](#)), and bend the pack along the length.
- 3 Firmly squeeze the red side of the resin as shown in B (see [Figure 7-24](#)), forcing it through the center seal and into the black side.
- 4 Mix thoroughly to a uniform color by squeezing the contents back and forth 25-30 times.
- 5 Squeeze the mixed, warm resin into one end of the bag, and cut off the other end.
- 6 Slowly insert the wiring connections into the sealing pack until they fit snugly against the opposite end as shown in C (see [Figure 7-24](#)).
- 7 Twist the open end of the bag and use the tie-wrap to close it. Position the tie-wrapped end upwards until the resin solidifies.
- 8 Push the epoxy sealed bag into the J-box. Replace and tighten the J-box cover.

To TLS Console

Wiring from the ISD Flow Meter J-box terminates at the TLS console. For additional information, refer to the 577013-796 - *ISD Vapor Flow Meter Installation Guide* (Veeder-Root document). For correct polarity connections, see [Figure 7-25](#).

Note: Correct polarity must be observed when making the connection.

Figure 7-25: Field Wiring ISD Flow Meter Polarity

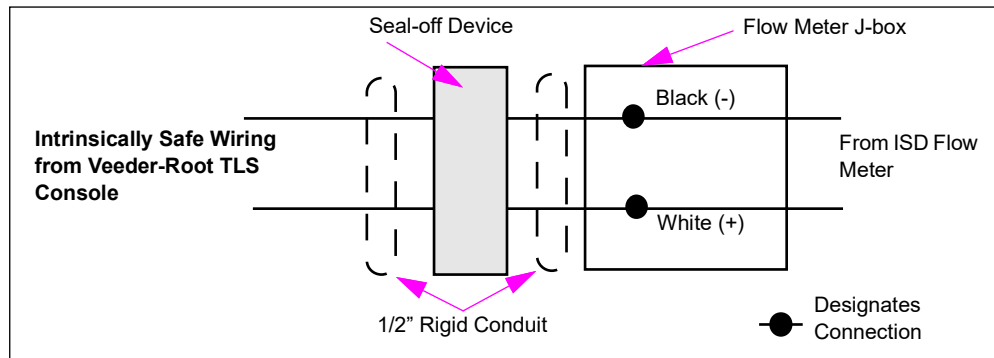

This page is intentionally left blank.

8 – Installing Breakaways, Hoses, Swivels, and Nozzles

Teflon tape must not be used for hanging hardware. Sealant must not be used for sealing connections unless the threads involved are pipe threads. O-ring seals do not require sealant. However, a small amount of silicone sealant can be used to avoid rolling or damaging of the O-ring during assembly.

When installing components in E25/E40 and E85 units, refer to “[Important Requirements for E25/E40 and E85 Units](#)” on page 4-3.

WARNING

Hold-open devices on nozzles that are not of the pressure activated type, can allow flow to occur through the nozzle for an activated fueling position, without the subsequent customer manually opening the nozzle.



Spilt or uncontrolled dispensed fuel may result in potential fire, explosion, fuel chemical burns, or environmental contamination. Serious injury or death may result.



As per Gilbarco and certain standard (NFPA 30A) requirements, pressure activated nozzles must be used for installations that use pump/dispenser or Point of Sale (POS) activated pre-set operation, or alternately, where a latch hold open device is used on a non-pressure activated nozzle, the latch hold open device must be removed. Consult the nozzle manufacturer for their recommended nozzle model types and safety recommendations.

WARNING

The hose pulled away from the pump/dispenser could drain fuel or pull the unit over during a drive-off. Explosion and fire or pull off of the dispenser during a drive-off could result in severe injury or death.

Installation of breakaways is required according to NFPA 30A.

WARNING

Use of hoses other than standard lengths may create a tripping hazard.

Tripping could result in severe injury or death.

Do not use excessively long hoses without a hose retractor.

⚠ WARNING

DEF, flexible fuels such as biodiesel; high alcohol percentage fuels, and so on, may be incompatible with certain plumbing materials and hydraulic components.

Use of incompatible materials or components with alternative fuels or DEF can result in leaks or unexpected failures of components resulting in fire or explosion or environmental damage. When installing components in E25/E40 and E85 units, refer to “Important Requirements for E25/E40 and E85 Units” on page 4-3.

When dispensing alternative fuels or DEF, verify with the manufacturer of the material or component that all plumbing components are compatible with the fuels or DEF being dispensed.

CAUTION**DEF Hose Torque**

Recommended torque when installing hoses is 40-50 Nm (30-35 ft-lbs). DO NOT OVERTIGHTEN or damage to the nozzle could occur. Applicable when connecting hoses to the skid tank, during internal repairs, and nozzle replacement.

CAUTION**Applicable to Dispensers Rated for E25/E40 and E85 Use:**

Use only UL-listed TPS PTFE Pipe Sealant manufactured by SAF-T-LOC International Corp.

Teflon tape must be used **only** at the inlet pipe connection.

DEF nozzles require an inlet strainer installed at the nozzle inlet. If you are installing DEF nozzles, ensure to install the strainer with the dome facing upstream.

Units Without Hose Retractors

To install breakaways, hoses, and swivels in pumps/dispensers without extended reach or hose retractors, proceed as follows:

- 1 Install the breakaway whip hose to the pump/dispenser outlet casting (see [Figure 8-1](#) on [page 8-3](#)).
- 2 Install the listed breakaways to the whip hoses. Follow the breakaway manufacturer’s instructions:
 - Clean all threads.
 - Place the sealant on male threads only. Follow the sealant manufacturer’s instructions.
Note: Use only UL-classified pipe sealant approved for use with petroleum products. Remove the sealant if it is found inside the hose or fittings. Clean off the excess sealant. Do not use Teflon tape as it may damage the unit.
 - Use a smooth-faced wrench to tighten all fittings securely. Do not overtighten.
Note: Do not tighten the breakaway by twisting the hose. This can damage the coupling.

- 3 Install the hose to the breakaway.

Figure 8-1: Hanging Hardware

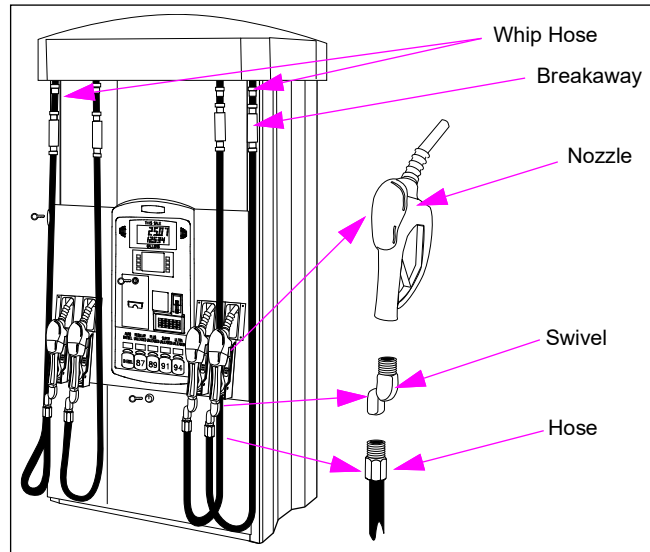

- 4 Install the swivel (if used) to the hose. Follow the swivel manufacturer's instructions.
- 5 Install the nozzle to the swivel or the hose. Follow the nozzle manufacturer's instructions.
Note: Check for the correct nozzle cradle/hook type (vapor, non-vapor, and so on). It must not be possible to activate the nozzle boot switch with the nozzle properly held in place in the nozzle boot.
- 6 Use an ohm meter to check for continuity from the end of the nozzle to the conductive metal surface in the unit (applies to both types of hose-retrievers or non-retrievers).

Units with Hose Retrievers or Extended Reach

Note: It is important that Teflon tape not be used on threaded connections, as parts may be damaged during tightening. Use a UL-approved sealant suitable for the fuel involved, only where a sealing is required (not used for O-rings).

⚠ WARNING

Hose fittings and attachments, if improperly grounded, can lead to a spark that may ignite fuel or its vapors.

Explosion or fire could result in severe injury or death.

Check the hoses, breakaways, and fittings for proper conductivity after assembly.

To install breakaways, hoses, and swivels in units with hose retrievers/extended reach, proceed as follows:

- 1 Assemble the hose to the unit's outlet casting. Follow the breakaway manufacturer's instructions.
- 2 Assemble the breakaway to the hose. Follow the breakaway manufacturer's instructions.
- 3 Attach the whip hose to the breakaway. Follow the breakaway manufacturer's instructions.
- 4 Attach the swivel (if used) to the nozzle. Follow the swivel manufacturer's instructions.
- 5 Assemble and attach the breakaway whip hose to the swivel or nozzle. Follow the hose manufacturer's instructions.
- 6 Attach the retriever clamp to the long hose positioned to allow maximum extension of the hose, yet not allow a trip hazard.
- 7 Adjust the tension on the retriever mechanism to ensure that the hose retracts fully. For details, refer to the kit or manufacturer's instructions.

 **WARNING**

Hose breakaways may not operate properly during a drive-off if the retriever clamp is located between the breakaway and pump dispenser.

The unit may be pulled off an island during a drive-off or fuel may be spilled resulting in a serious injury to death.

Do not install the hose retriever clamp between the nozzle and breakaway for units with hose retrievers.

DEF Dispensers - ZVA™ DEF Nozzle

A Magnetic Nozzle Adapter (M10656B001) is required for each technician servicing the DEF units.

Note: The magnetic nozzle adapter is required only for the M10257B001 Nozzles. M10257B002 Nozzles do not require this adapter.

DEF Nozzle (M10257B001 and M10257B002)

Figure 8-2 shows the DEF nozzle.

Figure 8-2: DEF Nozzle

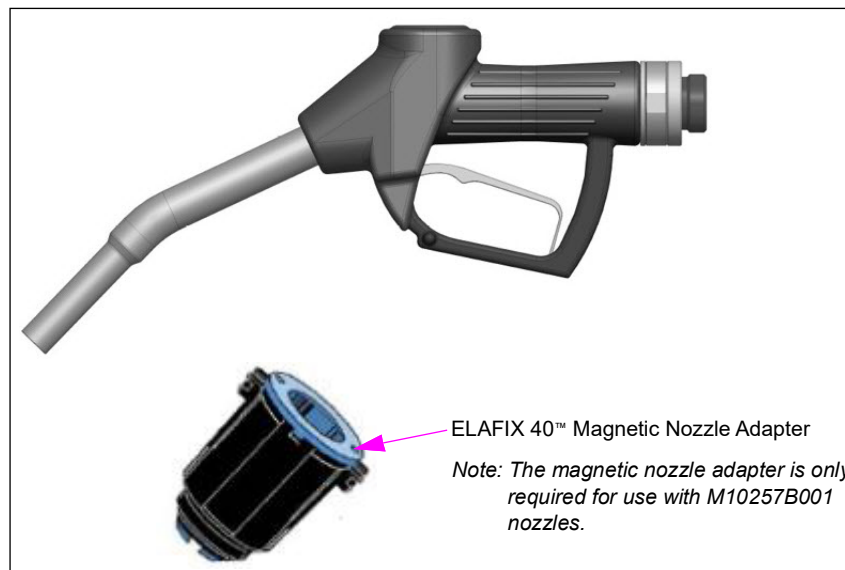

The DEF nozzle is designed to dispense DEF. No other nozzle type is currently approved. The DEF nozzle is manufactured by OPW.

- The nozzle is a non-vapor recovery nozzle. Conventional performance and troubleshooting procedures for non-vapor recovery nozzles are also applicable to the DEF nozzle.
- In addition to fluid compatibility, some nozzles require a ring magnet to be slipped over the spout to dispense DEF. Normally this ring magnet is part of the construction of the vehicle DEF tanks. It helps to prevent DEF from being dispensed into the diesel tank that will result in severe damage to the engine. The technician must have a ring magnet or its equivalent to dispense DEF through the nozzle during tests. The test magnetic nozzle adapter is available from Gilbarco.
- The nozzle handle also contains the activation magnet that is part of the pump handle system.
- The nozzle can freeze if the cabinet heater fails, power is lost, or the nozzle door does not drop down completely during cold weather. The nozzle must be checked for leaks and operation after thawing.

Dispenser DEF Strainer (M10820A001)

Filtration is required to protect nozzles and valves. The earlier versions of the dispenser relied completely on a filter tank system. The later versions of the dispenser have a strainer. The 100-micron strainer and assembly is compatible with DEF. The strainer must be cleaned after the first air purging and calibration to ensure good flow rates. Refer to [“Purging Air from System and Testing”](#) on [page 9-5](#).

Hose Breakaway/Swivel (M10258B001)

The Swivel (M10258B001) is compatible with DEF. If the swivel freezes in very cold weather with no heat in the cabinet, the breakaway can pop. It is resettable as per the manufacturer’s instructions. Check for leaks and proper retention after repair. Follow any manufacturer’s recommendations on repair procedure and the maximum number of times the breakaway can be reset.

9 – Completing Installation

Do Not Turn on AC Power

 **WARNING**

Applying power before electrical and mechanical inspections have been completed can be hazardous. Hazardous high voltage, fuel, and fuel vapors may be present or the equipment may be damaged.

 Serious fires, explosions, and electrical shocks could result in injuries or deaths.

 Power must not be applied to the unit and associated STPs when installing, servicing or making electrical wiring connections, or replacing any electrical components, including light bulbs. Multiple disconnects may be required.

Power must only be applied to the unit after the commissioning Gilbarco ASC checks wiring and so on. The installer must inspect the unit per [“Installation Checklists”](#) on [page 9-2](#) before contacting the commissioning ASC. Incorrect installation could result in an unsafe unit condition. Damage from improper wiring or installation will not be covered by warranty.

When all installation procedures are complete up to this point, the unit must be inspected by a Gilbarco ASC using the following checklists:

- *MDE-4227 Encore/Eclipse Start-up Checklist (Form B).*
- *MDE-4228 Encore Commissioning Checklist (Form C).*

For DEF units, use the following checklists:

- *MDE-4898 Start-up Checklist for Diesel Exhaust Fluid (DEF) Units (Form B).*
- *MDE-4899 Commissioning Checklist for Diesel Exhaust Fluid (DEF) Units (Form C).*

After the inspection is complete, the system must be purged by the installing contractor. For start-up instructions, refer to *MDE-3804 Encore and Eclipse Start-up/Service Manual*. Irrespective of when the purging operation is performed, proceed to [“Installation Checklists”](#) on [page 9-2](#).

Installation Checklists

To ensure proper and safe operation of all equipment and warranty coverage, installers must inspect the installation and then complete the *MDE-4226 Encore/Eclipse Installation Checklist (Form A)* [for DEF units, you must complete *MDE-4897 Installation Checklist for Diesel Exhaust Fluid (DEF) Units (Form A)*]. The “[Mechanical and Hydraulic Related Items](#)” checklist and “[Electrical Related Items](#)” on [page 9-3](#) checklist may be used as a guide (many of the items on the lists must already have been checked by the electrician as covered earlier).

MDE-4226 Encore/Eclipse Installation Checklist (Form A) Name	In the Following Checklists, MDE-4226 Checklist Referred To As
Individual Pump/Dispenser Hydraulic/Mechanical Related	List 1
Individual Pump/Dispenser Electrical Related	List 2
Station Electrical	List 3

Follow the checklists and perform all the required inspections. After the inspection has been completed, insert *MDE-4226 Encore/Eclipse Installation Checklist (Form A)* (reduce your copy) in the dispenser electronics cabinet away from and not touching any electronic component [for DEF units you must insert *MDE-4897 Installation Checklist for Diesel Exhaust Fluid (DEF) Units (Form A)*]. The forms must be provided with each unit, if not, contact the Gilbarco distributor. It is only required to complete the station electrical inspection portions of the form (list 3) in every form, (for every unit at the station).

Note: To preserve the originals for future use, make several copies of all the checklists in this manual.

Mechanical and Hydraulic Related Items

Item	Procedure	Refer To	Checked	MDE-4226 Related Item
1	Shear valves must be installed according to the valve manufacturer’s recommendations. Shear point is ± 0.75 " of grade and properly mounted. Vapor line shear valves are required for many localities.	page 6-13 of this manual		List 1, Item 1
2	The lower piping brace must be installed according to the installation manual and all product pipes must be properly anchored to it. <i>Note: Not applicable to skid tank-mounted DEF dispensers.</i>	page 6-5 of this manual		List 1, Item 13
3	Flexible pipes must not be used within the dispenser. However, flexible pipes that meet the local and state codes can be used below the pump/dispenser, when allowed by regulatory authorities. <i>Note: Not applicable to fluid lines containing DEF.</i>	<i>MDE-3802 Encore and Eclipse Site Preparation Manual</i>		List 1, Item 2
4	Pumps (self-contained units) must have a vacuum actuated pressure regulating valve (Gilbarco Model 52 or equivalent) to prevent positive pressure at the pump base when used with above ground tanks.	<i>MDE-3802 Encore and Eclipse Site Preparation Manual</i>		List 1, Item 3
5	Hose breakaways must be used and installed according to the manufacturer’s recommendations. For units with retrievers, breakaways, and whip hoses must be attached to the nozzle end. For units without retrievers, it is attached to the dispenser end.	Manufacturer’s specifications		List 1, Item 5
6	All hanging hardware must be checked for continuity. <i>Note: Not applicable to DEF dispensers.</i>	page 8-1 of this manual		List 1, Item 6
7	The unit must be properly anchored to the island or skid tank.	page 6-13 of this manual		List 1, Item 7

Item	Procedure	Refer To	Checked	MDE-4226 Related Item
8	Vapor recovery piping at the pump/dispenser must have no traps or sags. Unit must be mounted using proper quantity, size, and strength mounting hardware.	page 6-12 of this manual		List 1, Item 8
9	Verify correct nozzles, piping and brand panels for each grade. Also, verify if correct product lines are connected to each pump/dispenser inlet.	Unit order specific		List 1, Item 9
10	All code, regulatory agency, or customer-specified safety warning signs, labels, or decals have been installed.	As provided with and for unit		List 1, Item 10
11	Long hose lengths beyond Gilbarco recommendations must not be used without special retrievers. <ul style="list-style-type: none"> • For VaporVac hoses, no more than 6" of hose length may rest on the ground when the nozzle is resting in the boot. • For balance vapor recovery hoses, no portion of the hose may be on the ground. 	NFPA 30A		List 1, Item 11
12	Verify shear valve, nozzle, and dispenser proper shutoff operation.	page 9-10 of this manual		N/A
13	Units with Ecometers must run with recommended filters.	page 4-6 of this manual		List 1, Item 15

Note: For DEF units, refer to MDE-4897 Installation Checklist for Diesel Exhaust Fluid (DEF) Units (Form A)

Electrical Related Items

Item	Procedure	Refer To	Checked	MDE-4226 Related Item
1	Conduit entries into the electronics cabinet must be installed according to the installation manual. No unplugged openings must be allowed between the electronics cabinet interior and the vapor barrier or at the side of the electronics cabinet.	page A-21 , page 7-25 , and page 7-26 of this manual		List 2, Item 1
	Field conduit into the electronics cabinet must be properly potted according to the local, state, and national codes as per the installation manual. This is in addition to potting requirements for the conduit below the base of the pump/dispenser.			List 2, Item 2
2	It is not a requirement, but it is acceptable/allowable to secure field installed conduit to the fuel piping cross brace in the hydraulics cabinet.	page 7-6 of this manual		List 2, Item 3
3	Equipment must be installed in conjunction with an emergency power cutoff to remove all power from the equipment in case of an emergency.			List 3, Item 2
4	STP isolation relays are required for all dispensers.			List 3, Item 3
5	Use twisted-pair wires as specified for two-wire communication for new installations or where a new wire is pulled. Do not use shielded wires for video feed, for SMART Connect and Applause™ Media System.	<ul style="list-style-type: none"> • MDE-3802 Encore and Eclipse Site Preparation Manual • FE-321 Field Wiring Diagram Gilbarco STP Isolation Relay Box PA0287, 120 VAC • FE-363 Field Wiring Diagram Encore 500/700 (M07555 Power Supply Only) • FE-364 Field Wiring Diagram for Encore 300 • "Grounding" on page 10-14 		List 2, Item 5
6	Use twisted-pair wires for color display communication wiring.			List 2, Item 5
7	All wiring must be of stranded copper of the gauge and insulation casing specified.			List 2, Item 6
8	All grounds must be properly connected according to the installation manual requirements as well as the state, local, and national codes.			List 2, Item 7

Item	Procedure	Refer To	Checked	MDE-4226 Related Item
9	Conduit and J-boxes must be approved for hazardous locations and properly sized for the wiring involved.	<ul style="list-style-type: none"> • NFPA 30A • NFPA 70 • UL 87 • NEC 		List 2, Item 8
10	Properly size all circuit breakers for the units/unit options involved.	NEC and local codes		List 3, Item 5
11	All pump/dispenser wiring must be properly spaced and isolated from wiring for electrically noisy devices, such as variable speed STPs, station equipment motors, and other devices.			List 3, Item 6
12	All power wiring and circuit breakers to Gilbarco equipment must be dedicated and not be shared with other equipment.			List 3, Item 7
13	All circuit breakers to Gilbarco equipment must be clearly labeled and readily accessible.	<i>MDE-3802 Encore and Eclipse Site Preparation Manual</i>		List 3, Item 8
14	All distribution boxes must be clearly labeled showing the pump/dispenser number connections.			List 3, Item 9
15	All pumps/dispensers must be wired to the same phase of electrical power.			List 3, Item 10
16	New site wiring must be megger-tested and wired to the same phase. Old site wiring must be continuity and short-tested with a digital meter.	page 7-23 of this manual		List 3, Item 11
17	Wiring must be color-coded or tagged, sized for distance and application, and resistant to gas and oil.	page 7-5 of this manual		N/A
18	J-boxes must be secured with all bolts and have no unplugged openings.	page 7-5 of this manual		List 2, Item 9

Note: For DEF units, refer to MDE-4897 Installation Checklist for Diesel Exhaust Fluid (DEF) Units (Form A).

Purging Air from System and Testing

About Purging System

Check with your local and state agencies for meter calibration regulations. If the regulations exceed these procedures you must follow your local and state regulations.

Before any calibration procedures can be completed, remove all air from the lines and dispensers. When purging air at a new site start-up, an existing location with STP, or line repair, perform the following steps:

Individual Product Line Purging Procedure

- 1 Ensure the shear valves in all dispensers are closed aside from the unit furthest away from the STP.
- 2 Purge a minimum of “500” gallons through the shear valve test port of each product in the dispenser furthest away from the STP of each trunk line.
 - If multiple STPs are used in a manifold line configuration it is required to run all STPs for that manifold=line set at the same time. Operating STPs in an alternating configuration should not be used during purging. Ensure that the line programming is changed to All Pumps for the purging process. Ensure that you revert the programming after purging is completed.
 - The number of gallons needed for purging varies depending on line length, line type, line diameter, and flow rate. The purge amount should not be less than 500 gallons.
 - The number of fittings and other physical variances, such as air traps, could also adversely affect the ability to purge air out of the lines. Larger volumes of fuel may be needed to ensure all air is purged from the lines and fittings.

Individual Meter Purging Procedure

- 1 After the initial rush of air and full product flow is achieved from the “[Individual Product Line Purging Procedure](#)”, purge “50” gallons through the nozzle for each straight product after the initial 500 gallon purge. This must be done through each meter of each dispenser starting with the furthest dispenser from the STP working your way back to the STP. Shear valves must be opened individually as each individual product is being provided at each dispenser while working back toward the STP.

IMPORTANT INFORMATION

For Ecometer equipped units, never exceed the nozzle slow latch setting until fuel flow is steady.

Post Service Purging Procedures

- 1 After performing service on the hydraulic section of the dispenser, perform air purging using the “[Individual Meter Purging Procedure](#)” on [page 9-5](#). To determine how much fuel to dispense when purging through the nozzle, refer to the following table:

Action Performed	Minimum Purge Amount
System with fully purged product lines	50 Gallons (190 Liters)
Major Services: <ul style="list-style-type: none"> • Meter replacement • Valve replacement • Pumping unit replacement • Manifold assembly replacement • Product tubing replacement 	25 Gallons (95 Liters)
Minor Services: <ul style="list-style-type: none"> • Changing filters • Cleaning/replacement of strainer • Hanging hardware replacement/service • Outlet casting replacement 	10 Gallons (38 Liters)

For New Dispensers (Purging Through Shear Valve)

The Encore dispensers must have some programming changes completed before purging can be started.

Note: Purging of units with Ecometers is similar to C+ meters but more care must be taken. For more information, refer to “[Installation Considerations for Units with Ecometers](#)” on [page 4-6](#).

Encore 500/500 S/700 S/900

The Encore 500/500 S/700 S/900 units are received precalibrated, but must be checked for calibration before use. Purging requires the unit to be configured for gallons, liters, or imperial gallons. For quick reference calibration information, refer to *MDE-4281 Calibration Quick Reference Card Encore 300/500/550, and Eclipse Units*.

IMPORTANT INFORMATION
When purging Encore 500/500 S/700 S series units, if you exceed more than 250 volume units for any meter on a side, the start-up technician will not be able to reset the volume totals to zero or any other value for opening the station. Avoid purging of more than 200 units of volume per meter as a result. Purging, calibration, and calibration verification can be performed within this limit and totals reset, if required.

Encore 300

The Encore 300 units are received uncalibrated. Purging requires the unit to be configured for gallons, liters, or imperial gallons. When purging, perform the calibration procedure in “[Special Steps for Purging Air from Underground Lines](#)” on [page 9-7](#).

- For full calibration information, refer to *MDE-3804 Encore and Eclipse Start-up/Service Manual*.
- For quick reference calibration information, refer to *MDE-4281 Calibration Quick Reference Card Encore 300/500/550, and Eclipse Units*.

Programming Units of Measure

For Encore 300 units, this procedure is referred to as setting the conversion factor. For other Encore units, this is referred to as setting volume units.

- For full programming information, refer to *MDE-3804 Encore and Eclipse Start-up/Service Manual*.
- For quick reference programming information for Encore 300 units, refer to *MDE-4039 Encore 300 Programming Quick Reference Card*.
- For quick reference programming information for Encore 500/550/700 S/900, and Eclipse units, refer to *MDE-3860 Programming Quick Reference Card*.

Special Steps for Purging Air from Underground Lines

For sites with underground lines not filled with fuel, air must be purged from the lines before purging the dispenser.

CAUTION

Do not attempt to purge these lines using the dispenser nozzle as the dispenser meters may suffer damage due to overspeed.

To purge air in Encore 300 units, refer to the procedure in *MDE-3804 Encore and Eclipse Start-up/Service Manual*.

To prepare for purging, use the following steps for each shear valve in all units. Be observant during purging and check for plumbing leaks as you move toward the tank. For blender nozzles, select a blend grade. Ensure that the prices are set (by the ASC) before you begin.

- 1 Turn off all power to the STPs involved.
- 2 Start with the unit farthest from the tank.
- 3 Use a UL-approved sealant to connect a “gasoline suitable, conductive hose” to the shear valve test port.
- 4 Install the mechanical valve (petcock) to the hose.
- 5 Place the drain end of the closed valve in an approved metallic container. Clean up any spills promptly.
- 6 Turn on power to STPs. Activate the STP for the line being purged.
- 7 Slowly open the mechanical valve until you obtain a slow, constant stream of fuel flow. Maintain contact between the metallic valve and the can during fuel flow.
- 8 Turn off STP, bleed pressure using the mechanical valve, remove the valve and hose, and reinstall the pipe plug to the shear valve using UL-approved sealant suitable for the fuel involved.
- 9 For purging air from the system with fuel in lines, perform all steps in [“For New and Existing Pumps and Dispensers with Fuel in Lines \(Purging Through Nozzle\)”](#) on page 9-8.

For New and Existing Pumps and Dispensers with Fuel in Lines (Purging Through Nozzle)

CAUTION

Purging air at high flow rates through the meter can permanently damage them. Noise is not an indication of overspeed in many cases.

Overspeed meter damage is not covered by warranty. Follow all instructions carefully.

Meters and other hydraulic devices can be permanently damaged by contamination if units are not equipped with filters during purging and other installation processes.

Non-use of filters during installation is considered abuse. Meters and other components that fail due to the contamination introduced during installation are not covered by warranty.

Never remove filters during installation. Ecometer and flexible fuel units require special filters. Do not substitute.

To purge air in new and existing pumps/dispensers where underground product lines are full with fuel, proceed as follows:

- 1 Lift the nozzle handle for the hose being purged.
Note: For purging in Encore 300 units, perform the procedure for purging in “For New Dispensers (Purging Through Shear Valve)” on page 9-6 for the selected meter.
- 2 Place the nozzle in the approved container.
- 3 Slowly open the nozzle until you obtain a slow, constant stream of fuel flow.
Note: For SMART Meter-equipped units, never exceed the nozzle slow latch setting until fuel flow is steady.
- 4 Purge the system with the amount of fuel specified in the following table:

For	Pump This Amount
Start-ups (installing new systems)	50 gallons (190 liters) per hose
Existing sites where the product lines are full	50 gallons (190 liters) per hose*

**This value depends on following the procedures in the sequence listed (especially for new sites). Purging more than 50 gallons (190 liters) may be required if the site has an unusual plumbing configuration (air traps or extreme line length). What may be good for most sites may not work for all. Generally, you can observe the effect of air if successive calibration checks read plus. After they stop reading plus, you have purged all the air.*
- 5 Return the nozzle to the nozzle boot.
- 6 Empty the approved container into an appropriate product tank.
- 7 Repeat steps 1 to 6 for each affected hose and each meter.

Purging Air in DEF Systems

Note: This procedure is usually required for the first unit you purge which must be the farthest from the tank.

Air passing through a DEF meter will trigger an error code. Therefore, you must temporarily replace the meter pulser connector to the door node with a standard Gilbarco Encore pulser, to properly purge the air from the system. To install a standard Encore pulser, proceed as follows:

- 1 Remove power to the unit.
- 2 Remove the pulser data connection at the pump node and replace with a standard Encore S pulser.
- 3 Restore power and activate the dispensing position.
- 4 Slowly hand spin the pulser to allow air to be purged through the system with the nozzle activated.
- 5 Purge the air, following the normal procedures, until DEF with minimal air is being dispensed.
- 6 Remove power to the unit.
- 7 Remove the temporary pulser and replace with the data connector from the Coriolis meter.
- 8 Restore power.
- 9 Complete the purging operation as per standard practice.

Later versions of Encore units have enhanced security software. You must periodically spin the pulser to maintain a higher purging flow rate.

WARNING

Do not substitute the pulser while power is being supplied to the unit. Lethal voltages exist within the dispenser and damage to the unit could occur if certain critical steps are not followed. It is recommended that only Gilbarco-certified ASCs, who are trained in the service and operation of Encore dispensers perform this procedure.

Notes: 1) DEF has the tendency to hold entrapped air more than diesel or gasoline fuels. This is more significant since most submerged pumps used with DEF do not have air separation systems and where overhead piping lines are used. Air in the system can significantly affect calibration setting accuracy.

2) Dispense a minimum of 75 gallons through each DEF hose. For overhead lines where no air bleed is used at a high point, purge amount can sometimes run into hundreds of gallons.

Verifying Shear Valve, Nozzle, and Dispenser Shutoff Operation

To verify correct shutoff function of the shear valve, nozzle, and dispenser, perform the following after purging air for all nozzles:

- 1 Close the shear valve.
- 2 Activate the fueling position associated with the shear valve.
- 3 Open the nozzle. Fuel must not continue to dribble out of the nozzle for more than a few seconds. If fuel continues to flow for a longer period, check the shear valve or nozzle for problems.
- 4 Close the nozzle.
- 5 Open the shear valve.
- 6 Activate the fueling position for the same fuel on the opposite side of the unit.
- 7 For the side to be tested (opposite activated side), remove the nozzle from the boot but do not activate the boot switch by raising the nozzle boot lever or allowing the auto on flapper to activate.
- 8 Open the nozzle. Fuel must not continue to dribble out of the nozzle for more than a few seconds. If fuel continues to flow for a longer period, check the nozzle or inform the ASC to check the dispenser valve or valve O-rings.

Calibration Procedure for Encore 300 Units

All the Encore 300 series meters must be calibrated, before their use by customers. For full calibration instructions, refer to *MDE-4281 Calibration Quick Reference Card Encore 300/500/550, and Eclipse Units*.

Calibration Procedure for Encore 500/500 S/700 S/900 Units

IMPORTANT INFORMATION

Units must be properly purged before calibration or calibration verification. Incomplete purging of air can result in inaccurate calibration or errors in calibration verification testing (normally, subsequent calibration checks will read plus). Always verify any calibration after setting.

The Encore 500/500 S/700 S/900 meters are precalibrated, but calibration must be verified. Depending on the type of unit (Encore 500/500 S/700 S/900 or Encore 300 series), the procedure is slightly different. After calibration, the Weights and Measures (W&M) switch must be seal-wired to prevent calibration tampering. Ensure that you draw the seal wire tightly.

Encore 500/500 S/700 S/900 (Gallon Unit of Measure)

Temporary pricing must be entered into the unit, as outlined in “Installation Checklists” on page 9-2 to allow dispensing and calibration.

The currently produced Encore 500/500 S/700 S/900 units are precalibrated to US gallons and programmed to default programming values.

Note: Perform the calibration verification procedure after calibration.

Programming Instructions - Level 1 Command Codes (CC) - [Setting Price per Unit (PPU)]

Level 1 commands are those commands most commonly performed on site by the station owner/operator.

Programming Level Default	CC	Range
Level 1	2222	20 - 39

- Press **F1** to perform additional programming.
- Press **ENTER** after making selection in all Levels.
- Press **F2** to exit programming.

Note: Entry of level 2, 3, or 4 PIN codes will also allow entry into Level 1 programming.

CC20: Set PPU Values

The layout and digit position for this programming feature is shown in Figure 9-1.

Figure 9-1: Set PPU Values

\$	2	0				Side
V				Grade		Level
PPU			Price	.Price	Price	Unit/ Price

To set the PPU values, proceed as follows:

- 1 Select Side 1, 2, or 3 (both sides).
- 2 Select the Grade.
- 3 Select the Price Level (Cash/Credit).
- 4 Enter the new PPU.

Note: Repeat for the other Side, Grade, and Price Level.

The units may be operated and purged in normal mode after entering prices. If the unit is in the gallon mode, purging can be performed eventually to convert them to metric mode.

Calibration and Accuracy Checks - DEF Dispensers

The same calibration procedure followed for Encore 500/500 S/700 S/900 dispensers is applicable to DEF dispensers.

IMPORTANT INFORMATION

The settling time for freshly dispensed DEF is longer than for gasoline or diesel. Therefore, a wait time of 3 minutes between dispensing the DEF into the prover can and taking the reading from the sight glass is recommended.

Programming Prover Can

To program the prover can, proceed as follows:

CC82

Calibration prover cans are typically set to 50 gallons for Ultra-Hi units. When calibrating a DEF meter, this must be set to 5 gallons (20 liters). If you do not reset the prover can size, then the calibration will be inaccurate. Ensure that you return the calibration prover can to 50 gallons for Ultra-Hi units after calibrating the DEF meter. Anytime you calibrate the DEF, you must temporarily revert the can size to 5 gallons (20 liters).

During purging, if the Coriolis meter does not have a reasonably high calibration factor installed, the DEF hose will start and stop flow rate repeatedly. This is because 10 GPM flow control valve of the dispenser turns the valve on and off to control flow rate, even if the real flow rate is well below 10 GPM. To prevent the issue, program the flow control to a number similar to the Ultra-Hi (CC80).

CAUTION

A stainless steel prover can must be used to calibrate DEF. Do not use a can that has been used for other fluids. Contaminated DEF can cause damage to vehicle engines, or contaminated fuel can corrode dispenser material(s), or damage vehicle engines.

An ELAFIX 40 Magnetic Adapter (M10656B001) must be pushed over the spout when you dispense DEF into the prover can during calibration or service. For details, refer to [“DEF Dispensers - ZVA™ DEF Nozzle”](#) on page 8-5.

Note: Some DEF nozzles may not require the magnetic adapter to produce flow.

Each time a meter is calibrated, a volume of DEF is generated. This DEF must be properly managed and cannot be discarded into the storm sewer or where it can possibly reach surface water or groundwater. If the DEF is to be returned to the supplier, store it in a closed, leak-free container.

Avoid dispersal of spilled material and runoff. Ensure that DEF does not come in contact with soil, waterways, drains, and sewers. Inform the relevant authorities if the product has caused environmental pollution (sewers, waterways, soil, or air).

IMPORTANT INFORMATION

For information on Back Room Communication Module [BRCM (PA04080000)], Two-wire Board Module 2 [TBM 2 (M11000A001)], and Dispenser Communication Module [DCM (M11356A001)] for Encore 700 S connection, refer to *MDE-4917 FlexPay Connect Distribution Box Installation Manual*.

10 – Reference Information

Information in this section is provided for the installing contractor's reference. The contractor may or may not be required by individual contract to perform all or any of the requirements outlined. However, all installations must conform to the requirements of this section. The information in this section can be found in detail in *MDE-3802 Encore and Eclipse Site Preparation Manual*.

Note: The information contained here is not to be used exclusively in lieu of the MDE-3802 Encore and Eclipse Site Preparation Manual, as not all the information contained in the document is found here.

Reference Contents

Section and Information	Location
Installation Differences when Replacing The Advantage Series	page 10-2
Electrical Requirements	page 10-3
Emergency Power Cutoff Switch	
Circuit Breakers	page 10-4
STP Control Relay Boxes for Dispensers	
STP Isolation Relays for Electronic Dispensers	
Conduit	page 10-5
Wiring	
Twisted-pair Wiring - Data Wire Lengths	page 10-7
Twisted-pair Conduit	
Twisted-pair Cable	
Ethernet Cable	page 10-8
Cable Ordering Information	
Ethernet Cable Installation Personnel and Procedures	
Grounding	page 10-14
Sealing 'Y' Fittings	page 10-15
Plumbing Requirements	page 10-16
Pipe Installation	
Pipe Size	
Pumps (Standard Flow)	
Pumps (High Flow)	
Dispensers (Standard Flow)	page 10-19
Dispensers (High Flow)	
Dispensers (Ultra-Hi High Gallon)	
Check Valves (Used on Pumps and Ultra-Hi Units only)	page 10-19
Shear Valves (Generally Used on Dispensers only)	

Installation Differences when Replacing The Advantage Series

Following table shows critical differences between The Advantage Series and Encore series that will affect installation:

Item	Description
Side Identification	<p>To emphasize plumbing differences between the Encore series and The Advantage Series, the nomenclature has been changed. There is no longer a reference to the sides as A and B as with The Advantage Series. The serial plate front of the Encore series (manufactured on or before December, 2002) is now side 1 and the back is side 2. Units manufactured after December, 2002 have the serial plate (label) mounted on the main door behind the CIM door on side 1. Side 1 is the primary service access side for electronics. Importantly, side 1 on an Encore unit replacing an existing The Advantage Series unit does not always replace The Advantage Series side A. In most cases:</p> <ul style="list-style-type: none"> • The Advantage side A and Encore side 1 are reversed for Encore Single-hose and Blender units. • The Advantage side A and Encore side 1 are the same for multi-hose units. <p>Also, the Encore series uses letters (W, X, Y, and Z) to differentiate the product pipes. The Advantage Series units are typically labeled as low and high or A, B, and so on.</p>
Piping Layout	<p>Do not assume piping connections for the Encore unit based on The Advantage Series or other unit piping.</p> <p>Dispensers: Encore product plumbing, in some cases, is in the reverse order from The Advantage Series, is spaced differently and has other differences. Refer to one or both of the following:</p> <ul style="list-style-type: none"> • “Dispenser MPD Piping to Hose Fitting Configurations” on page 5-3. • “Encore Dispenser Blender Piping to Hose Fitting Layout (Model # NN1, NN2, NN3, NJ0, NLO, NL1, NL2, NL8, and NJ2)” on page 5-16. <p>Pumps: Encore product inlet and electrical connection locations on self-contained pumps are different from The Advantage Series (refer to “Encore Foundation Diagrams: 4 of 9 (Electrical Conduit Layout)” on page A-14). For pump product inlet to hose configurations, refer to one or both of the following:</p> <ul style="list-style-type: none"> • “Pump (MPD) Piping to Hose Fitting Configuration” on page 5-9. • “Encore Pump Blender Piping to Hose Fitting Configuration” on page 5-20.
Piping Installation	<p>Dispensers: The Encore unit is provided with a lower piping brace. The installer must secure plumbing to the lower brace as per the installation document otherwise, improper operation of the Shear Valves may result if a unit is knocked over. Flexible pipe cannot be used within the dispenser, but may be used below the dispenser. Refer to <i>MDE-3802 Encore and Eclipse Site Preparation Manual</i>. The Encore inlet plumbing only extends partially into the hydraulics cabinet. This allows much greater installation adaptability by using rigid piping when retrofitting to competitive equipment pit boxes and plumbing layouts. In addition to side-to-side inlet adjustment capability, the lower piping brace can be mounted forward or rearward for additional adaptation.</p> <p>Pumps: Pumping units in self-contained pumps are shipped without inlet fittings. At installation, the protective closure in the pumping unit inlet must be removed and replaced with proper inlet fittings. Refer to <i>MDE-3802 Encore and Eclipse Site Preparation Manual</i>.</p>
Frame Width	<p>There is only one frame width for the Encore series. The Advantage Series units come in wide and narrow frame types. The Encore series width is intermediate between the wide and narrow frame width of The Advantage Series. However, it is recommended to use a pit box designed or adaptor for the Encore for new stations or major renovations. Refer to one of the following:</p> <ul style="list-style-type: none"> • “Encore Foundation Diagrams: 2 to 9 (Dispensers with Piston Meters)” on page A-12. • “Encore Foundation Diagrams: 4 of 9 (Electrical Conduit Layout)” on page A-14. <p>Also, refer to <i>MDE-4166 The Advantage Series Unit to Encore Series Island Adapter Kit (M03064K001) Installation Manual</i>.</p>

Item	Description
J-box	<p>Dispensers: The Encore series units may ship with or without a J-box or field conduit. The conduit and J-box not part of an order is provided by the installer. This allows more versatility for electrical conduit routing. As the installer may install the J-box toward the front or rear of the unit, it is not recommended to use the location of the J-box openings as an indication of front or rear of the unit. Always use the serial plate to identify side 1.</p> <p>Pumps: The Encore series pumps have a factory-installed J-box, located on side 1, but the electrical power connection is a 1" NPT conduit inlet located on side 2. All electrical power wiring to the unit must enter the conduit on side 2 and feed to the J-box. The Ethernet and intercom connections must enter the unit on side 2. Refer to "Encore Foundation Diagrams: 4 of 9 (Electrical Conduit Layout)" on page A-14.</p> <ul style="list-style-type: none"> • J-boxes, conduit, and fittings must conform to all requirements listed and referenced in this manual. • For new installations, with proper pull of additional wire, it is possible for Encore to eliminate a J-box. The Advantage Series units always have a J-box.
Electronics Cabinet	The Encore series electronics cabinet has two field conduit inlets. Facing side 1, the ones to the center left are for power wiring while the ones to the center right are for intercom/Ethernet/call button/speaker wiring. In The Advantage Series, the power goes into the J-box and intercoms, and so on, usually in a special conduit up a side column. Ethernet will be an option for future Encore units with installation of an optional board in the electronics cabinet. All the Encore units have knockouts for Ethernet wiring although the option board is not currently available. Ethernet wiring can share the conduit with a speaker/intercom/call button.
Wiring in Electronics Cabinet	The Encore series units use wiring terminal blocks, as appropriate, for field wiring where The Advantage Series uses wire nut connections.
Mandatory Conduit Potting Requirements	The installer must pot each conduit entering the electronics cabinet in two locations as specified in this manual. One is at the entry into the electronics cabinet and the other is in the pit box. The Advantage Series units only require potting below the unit.
Calibration	All the Encore meters are electronically calibrated. The Advantage meters are mechanically calibrated. Refer to <i>MDE-3804 Encore and Eclipse Start-up/Service Manual</i> .

Electrical Requirements

Electrical requirements are as follows:

- Sites must be prepared according to NFPA 30A, NFPA 70, and applicable national, state, and local codes/regulations.
- All circuit breaker panels and relay boxes must be mounted securely to the wall.
- Only UL-recognized/approved components and/or systems may be used.
- Licensed electricians experienced with pump and dispenser installations must be used to make all electrical connections.
- It is required to wire dispensers, POS and D-boxes (etc.) on one (same) phase in a dedicated electrical panel and have other potentially noise sources, such as compressors, motors, etc. in a different electrical panel on their own phase.
- An earth ground is required for all circuits.

Emergency Power Cutoff Switch

Following are the requirements for emergency power cutoff switch:

- NFPA 30A and Gilbarco require the installation of one or more emergency power cutoff switches.
- An emergency power cutoff switch is a single control that removes AC power to all island equipment [pumps/dispensers, STPs, canopies, lights, and so on (see [Figure 10-1](#))].
- The emergency power cutoff switch must be accessible, labeled clearly, and installed away from any hazard that may occur at the pumps/dispensers. Cutoff switches must not be located more than 100 feet away from the pumps/dispensers.

Circuit Breakers

Figure 10-1: Switched Neutral Circuit Breaker

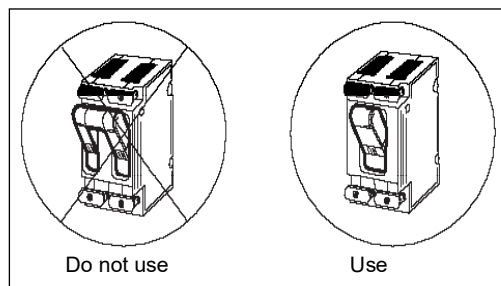

Following are the requirements for circuit breakers:

- A dedicated UL/CUL/CSA-listed switched neutral breaker is required for each circuit leading to a pump/dispenser or dispenser and STPs. It must be able to disconnect hot and neutral conductors simultaneously. Single-pole breakers with handle ties cannot be used.
- Only UL/CUL/CSA-listed circuit breaker panels are permitted for use.
- Circuit breakers must be installed away from the pumps/dispensers, readily accessible and clearly marked.
- A separate circuit breaker is required for each STP (dispenser models) or each pump motor (self-contained models).
- One circuit breaker is required for each pump/dispenser to allow the isolation of the pump/dispenser.

STP Control Relay Boxes for Dispensers

Following are the requirements for STP control relay boxes for dispensers:

- Gilbarco requires installation of STP isolation relays in addition to STP control relays. Combined STP control relay/isolation relay boxes are recommended.
- Each STP requires a separate control relay for each STP.
- Dispenser relay must not be used to power the STP.

STP Isolation Relays for Electronic Dispensers

Following are the requirements of STP isolation relays for electronic dispensers:

STP isolation relays provide electrical isolation between dispensers and prevent damage from cross phasing. Refer to *MDE-2755 STP Control and Dispenser Isolation Relay Box (PA0287)* and *FE-321 Field Wiring Diagram Gilbarco STP Isolation Relay Box PA0287, 120 VAC*.

Note: For 3-phase STP, use isolation relay at the input of the 3-phase STP control box.

- Gilbarco requires installation of STP isolation relays in addition to STP control relays. Combined STP control relay/isolation relay boxes are recommended.
- Isolation relays must be installed for each STP control line at each dispenser or dispenser grouping on a single circuit breaker.
- Neutral wire must be routed to the control relays from the dispenser circuit breaker (see field wiring diagrams).

Conduit

Gilbarco recommends that spare conduits be run for future high speed communications. For details, refer to “[Twisted-pair Conduit](#)” on [page 10-7](#).

- Use a minimum of 1-inch conduit for all Encore and Eclipse pumps/dispensers except for Encore Ultra-Hi, where you must use 3/4-inch conduit to connect wires to the pump/dispenser. InfoScreen® and two-wire data wires can share this conduit (see model-specific wiring diagrams).
- Use separate 1-inch conduit for e-CRIND® or intercom wiring. This is required for higher data rate Transmission Control Protocol/Internet Protocol (TCP/IP) communication.
- Run all power and light wires in threaded, rigid metal conduit or in a rigid non-metallic conduit. The conduit must conform to national and local electrical codes. If non-metallic conduit is used, it must be at least 2 feet underground. The last two feet of the underground run to the J-box must be a rigid metal conduit or threaded steel intermediate metal conduit.
- Never share the conduit or wire troughs with other manufacturer’s equipment (that is, speaker wires, and so on).

Note: The same conduit may be used for routing power to the pump/dispenser and the two-wire data loop (class 1 circuit). The two-wire data loop is a class 1 circuit.

- Metal conduit is not sufficient to provide an equipment ground. A separate ground wire must be used.
- Knock-out boxes or flexible conduit are not permitted for installation.

Note: Extra J-boxes added to the pump/dispenser must be listed class 1, division 1, group C and D explosion-proof.

- All electrical fittings must be listed for class 1, group C and D hazardous locations, as required by NFPA 30A and NFPA 70.
- A seal-off ‘Y’ fitting (for example, Killark Type EY) must be installed on all units as a first connection where the conduit leaves the ground.

For Installations in Canada

For installations in Canada the applicable code is CSA C22.1, The Canadian Electric Code (CEC). Other codes may apply and should be verified with the authority having jurisdiction.

IMPORTANT INFORMATION (Applies to the province of British Columbia only)

The **British Columbia Safety Authority** issued a decision stating that data cables and AC cables in the same conduit do not comply with the requirements for communication wiring as specified in CEC rule 60. In British Columbia, installing communication circuits, such as data cables and AC cables, in the same conduit as AC circuits is contrary to the CEC rule 60.

- New installations must have separate conduit for data/communication cables and power cables in the following circumstances (wiring for two-wire, data, communications, intercom, video, Ethernet, GLRE, must be in a separate conduit from the dispensers power and light conduit):
 - All new installations of fuel dispensers or other electrical equipment, whether or not the raceways are exposed and made readily accessible as part of the installation process; or
 - In any event if the raceways are exposed and made readily accessible for any reason.
- Separate conduits are not required in respect of the repair, modification or replacement of one or more existing pieces of electrical equipment or components thereof unless the raceways are exposed and made readily accessible as part of the repair, modification or replacement.
 - "Components" include card readers in fuel dispensers
 - "Electrical equipment" includes a fuel dispenser and "replacement" means the substitution of one electrical component or piece of equipment with another having the same essential function and provided always that:
 - * Neither the electrical rating nor the characteristics of the equipment is altered; and
 - * The replacement components are of a type which do not invalidate the original certification mark.
- A raceway is exposed and made readily accessible if it can be removed or replaced without significant additional disturbance to the material enclosing or overlaying it, including without limitation excavation of soil, asphalt or any other material by mechanical means, provided that a raceway is not to be considered exposed and made readily accessible merely because one or both ends of the raceway become visible during the repair, modification or replacement of electrical equipment or components.

Wiring

For high speed communications information, refer to ["Twisted-pair Conduit"](#) on [page 10-7](#).

- All pumps/dispensers must be wired according to NFPA 30A, NFPA 70, and applicable national, state, and local codes/regulations.
- All circuits must be class 1 NEC wired except the speaker (intercom) circuit which must be class 2 NEC. The speaker (intercom) circuit requires a separate 1-inch conduit.
- Only stranded gas and oil-resistant copper wire rated for 300 volts (up to 240 VAC source) and 176 °F (80 °C) may be used.
- In the main conduit, for communications, only twisted-pair, two-wire data pairs may be used.
- All dispensers must be wired on the same phase.
- Only listed wire nuts may be used for connections. Tape is not permitted.
- Seal-off Y fitting(s) must be potted after all wires are run and tested to termination points.

Twisted-pair Wiring - Data Wire Lengths

Refer to the following table to determine maximum data wire lengths:

For this Distribution Box (D-Box)	The Distance Between the D-Box and Dispenser	The Distance Between the D-Box and Console/Controller
PA0133, PA0187 G-SITE®	"Total" data wire system run no more than 2600 feet with 14 American Wire Gauge (AWG).	
PA0242 Transac® System 1000	No more than 2600 feet with 14 AWG.	No more than 2600 feet with 14 AWG.
PA0261 Universal D-Box (Two-wire Mode)	No more than 2600 feet with 14 AWG.	No more than 2600 feet with 14 AWG.
PA0306 D-Box	No more than 2600 feet with 14 AWG.	No more than 2600 feet with 14 AWG.
PA0409 D-Box	No more than 2600 feet with 14 AWG.	No more than 2600 feet with 14 AWG.
PA0261 (RS-422 Mode)	No more than 50 feet with 14 AWG.	No more than 2600 feet with 14 AWG.
PA0409 (RS-422 Mode)	No more than 50 feet with 14 AWG.	No more than 2600 feet with 14 AWG.

Note: When installing new two-wire communication wiring, use unshielded twisted-pair data wires. Do not use shielded wires. Wiring specifications: two-wire twisted-pair (UTP) with 10 to 12 twists per foot, stranded annealed copper tinned with 18 AWG minimum required for runs up to 1000 feet or 14 AWG minimum for runs up to 2600 feet. Do not use daisy-chain communications wiring. Insulation specifications: Polyvinyl chloride (PVC) insulation of type TFFN or MTW, UL-approved gasoline and oil-resistant. Refer C&M Corporation Part #27525 (18 AWG) or equivalent. Gilbarco part number for the wire is QI3221-02.

Twisted-pair Conduit

Gilbarco recommends the use of 1-inch rigid conduit and fittings (refer to ["Conduit"](#) on [page 10-5](#)) for twisted-pair cable(s). This will allow up to two speakers and two call/stop buttons per side, plus Ethernet.

Note: Terminate the conduit in the dispenser containment pan consistent with all national and local electrical codes.

Twisted-pair Cable

Gilbarco-specified cable must be used to permit issuance of a Certificate of Conformance (CoC) and/or warranty. Use of cables of other types may also create a hazardous situation.

⚠ WARNING

 Petroleum vapors may migrate inside the cable insulation between conductors and sheathing of various cables, including twisted-pair cables. Vapors may ignite, leading to serious injury or death.

 Use only twisted-pair cables specified by Gilbarco.

Cable Ordering Information

Refer to following table for cable ordering information:

Type	Comments
Q13221-02	Wire - 600 volt stranded, annealed copper tinned with PVC insulation. ~OR~
Type TFFN or NTW, 18 AWG	UL-approved gasoline and oil-resistant, wire with 10-12 twists per foot.

Ethernet Cable

Gilbarco requires use of 10 Base-T as specified in this manual.

Ethernet Cable Installation Personnel and Procedures

IMPORTANT INFORMATION

A copy of the “ANSI/TIA/EIA TSB 67 CoC” from the wiring personnel must be provided to the ASC before the site can be commissioned. The certificate is part of the documentation that must be on the file at the installation site.

A certification of the field test will be required at equipment start-up. For any questions regarding this procedure, contact Gilbarco.

Ethernet cables must be installed by certified telecommunications technicians in accordance with “ANSI/TIA/EIA 568-A Commercial Building Telecommunication Cabling Standards (with Amendments)”. The installing technician must read and understand the following:

Document	Title
ANSI/IEEE 142-1991	Recommended Practice for Grounding of Industrial and Commercial Power Systems (IEEE Green Book).
ANSI/IEEE 1100	Recommended Practice for Powering and Grounding Sensitive Electronic Equipment (IEEE Emerald Book).
ANSI/TIA/EIATSB67	Transmission Performance Specification for Field Testing of Unshielded Twisted-pair Cabling Systems.
ANSI/TIA/EIA568-A	Commercial Building Telecommunication Cabling Standards (with amendments).

There are two ways to connect high-speed data to the dispenser:

- a** An Ethernet or Category 5 (CAT5) cable installation.
- b** FlexPay Connect
 - POS controls CRIND on dedicated twisted-pair.
 - POS controls CRIND with pump data on same wire.
 - Applause on dedicated twisted-pair.
 - Applause with pump data on same wire.

Ethernet or CAT5 Cable Installation

Note: An Ethernet or CAT5 cable cannot be installed in power conduit as the maximum cable length is 300 feet.

IMPORTANT INFORMATION



Petroleum vapors may migrate inside the cable insulation between conductors and sheathing of various cables, including 10 Base-T or CAT5E cable. Vapors may ignite, leading to serious injury or death.



It is crucial that the installer follow NECs, article 501 requirements by removing the outer jacket and spreading the wire pairs at the seal-off points of the CAT5E cable, so that a good vapor seal is achieved. This is required because all CAT5E cables will conduct vapors inside their outer jacket.

Use gas-oil resistant CAT5 or CAT5E. For example, Belden® 7928a.

Conduit seal-offs required as per NEC, section 514.9. As the outer jacket defeats the seal-off, the jacket must be removed and the conductor pairs separated to allow a good seal (see [Figure 10-2](#)).

For non-US installations, consult local regulations.

Figure 10-2: Low-voltage Conduit

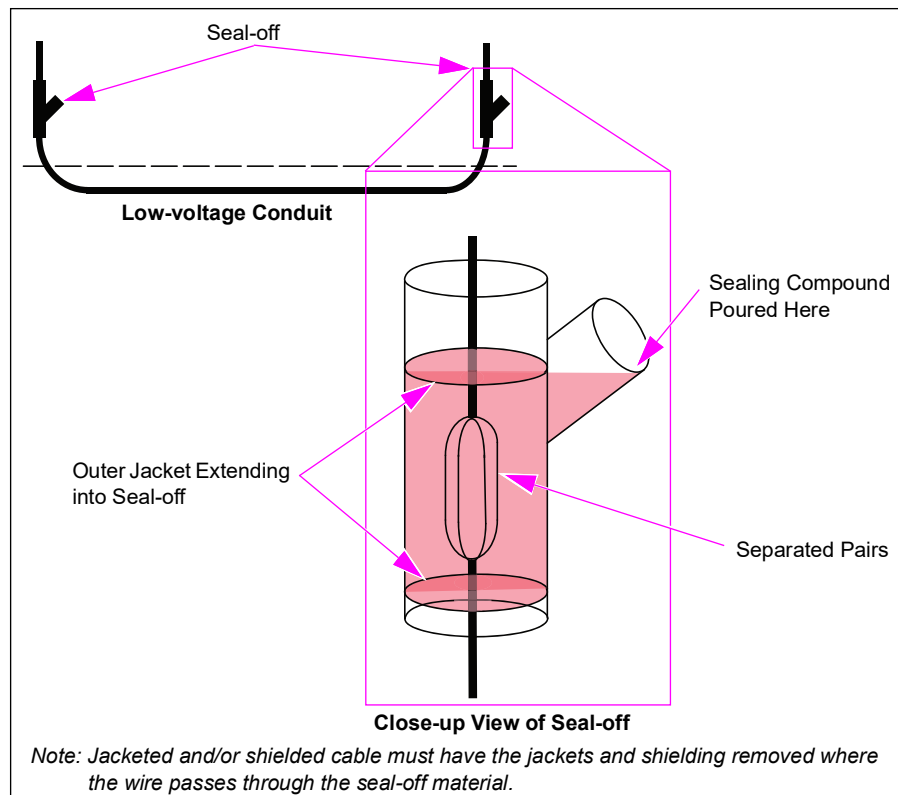

FlexPay Connect - High Speed Communications Wiring

Figure 10-3: POS Controls CRIND on Dedicated Twisted-pair

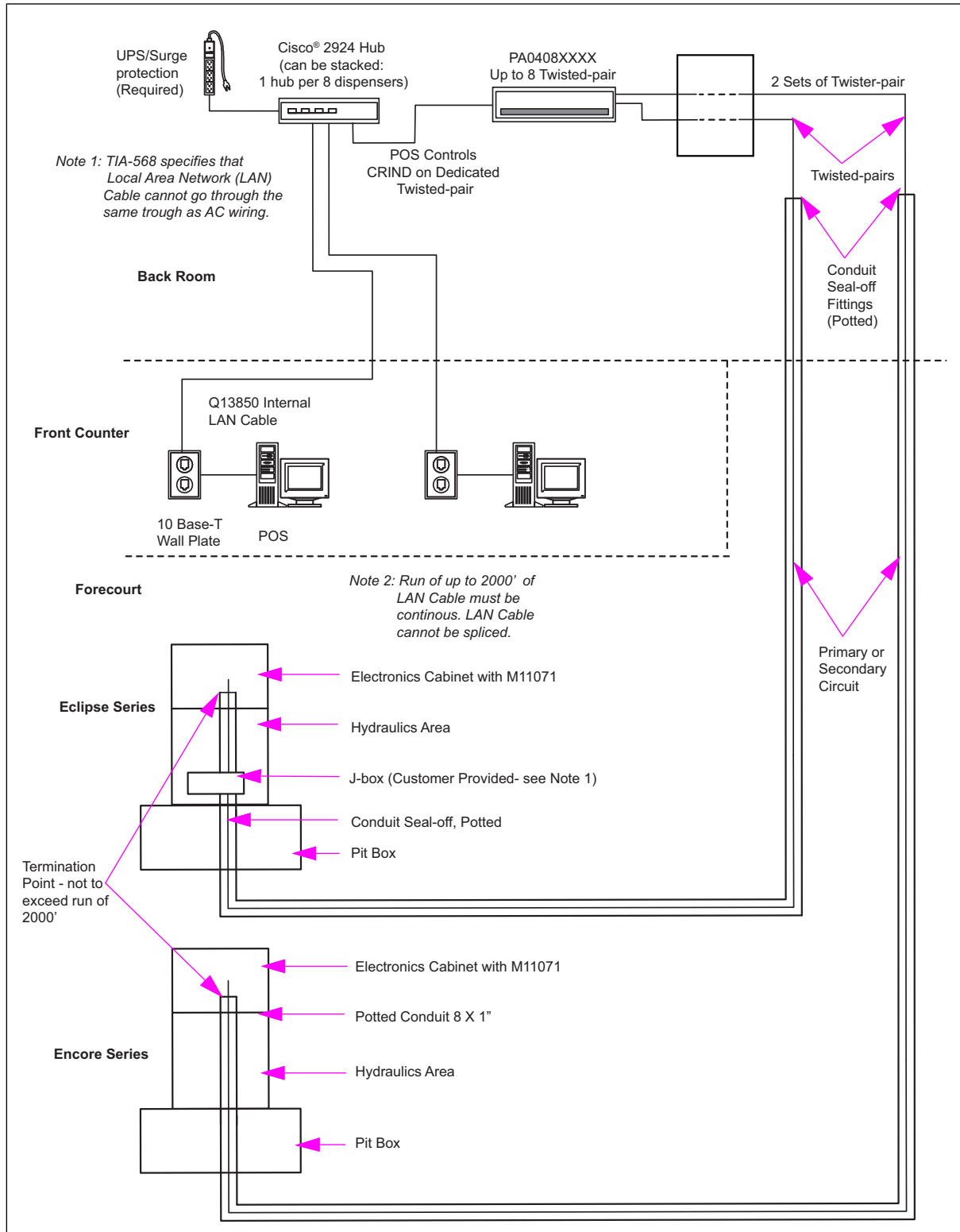

Figure 10-4: POS Controls CRIND with Pump Data on Same Wire

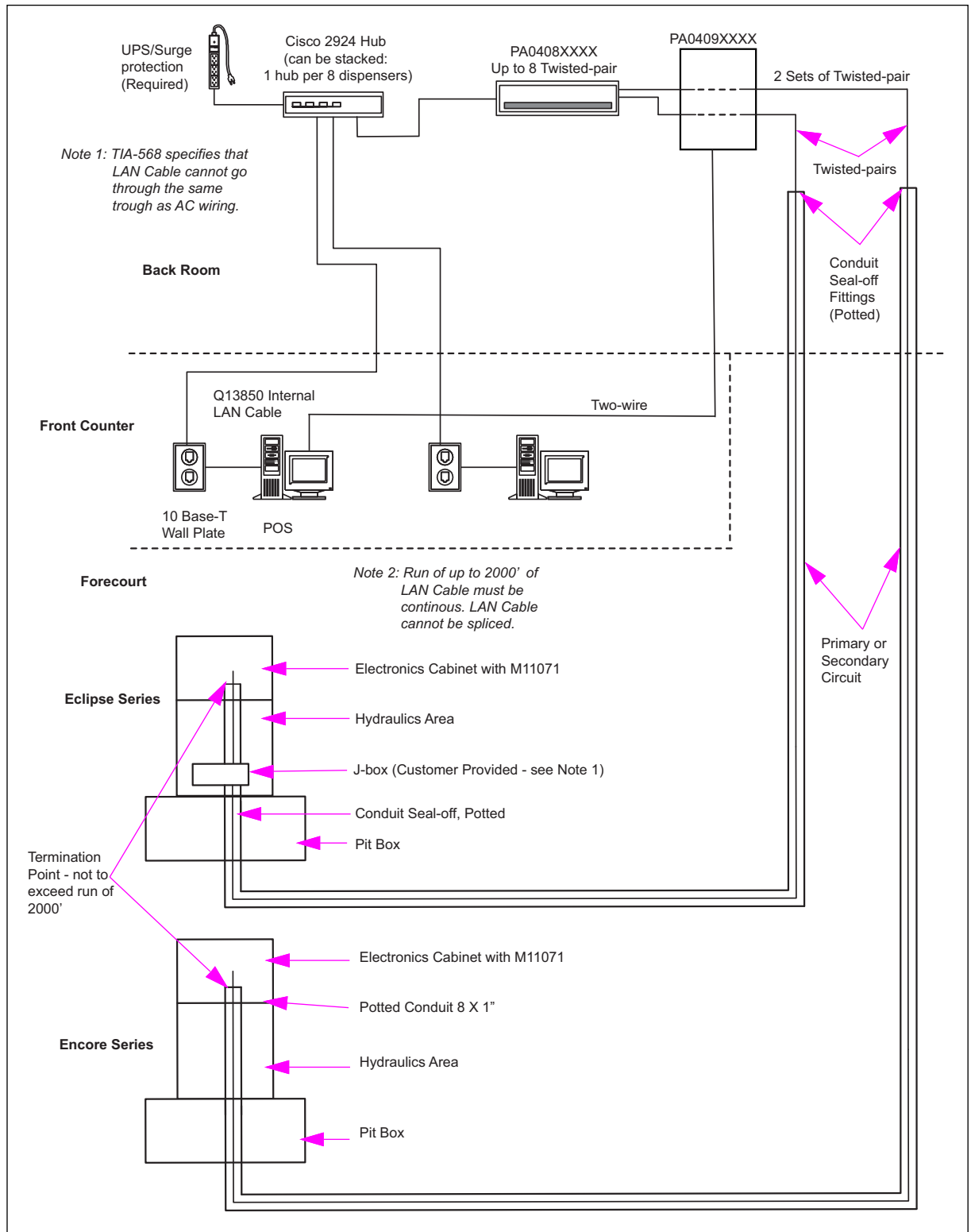

Figure 10-5: Applause on Dedicated Twisted-pair

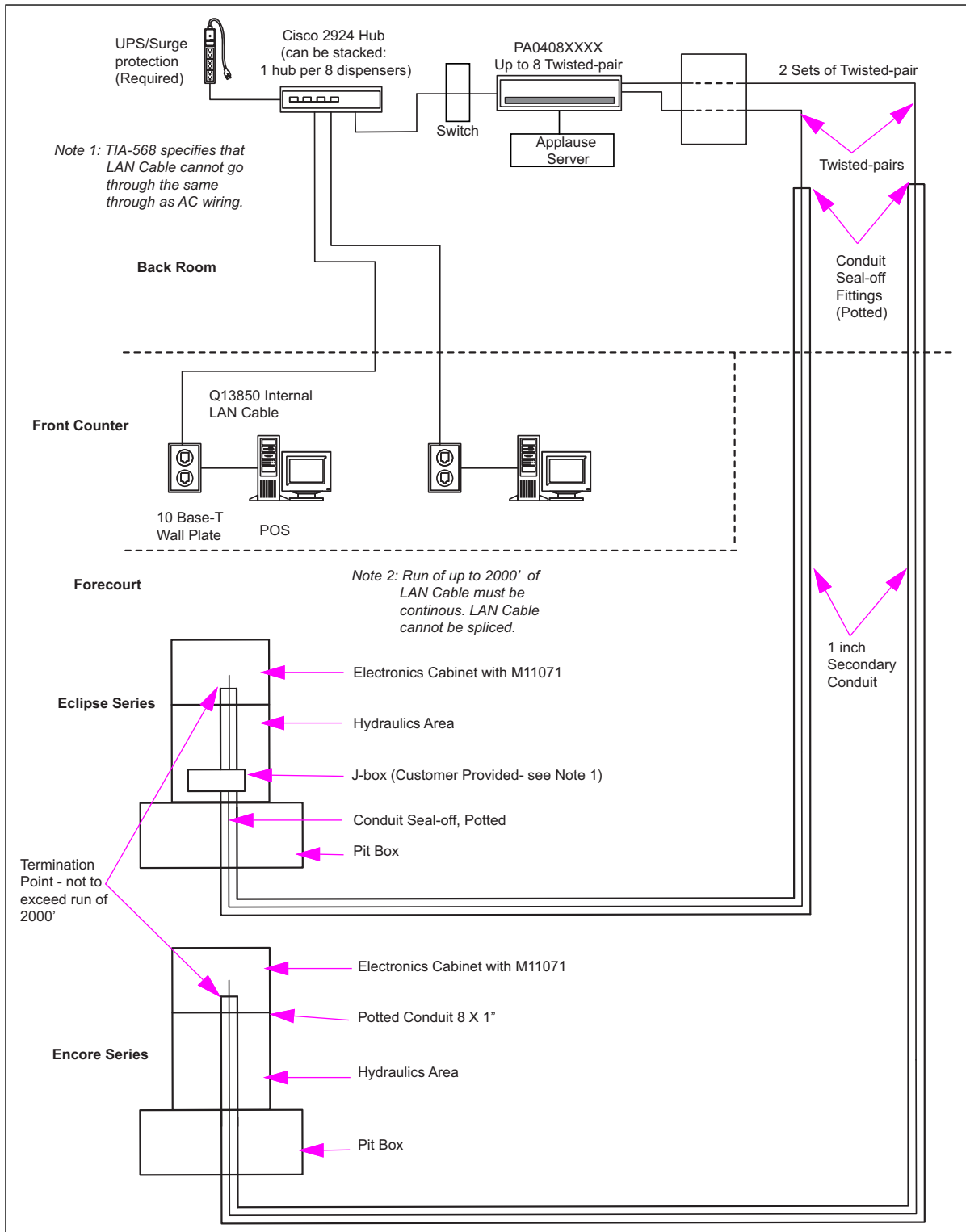
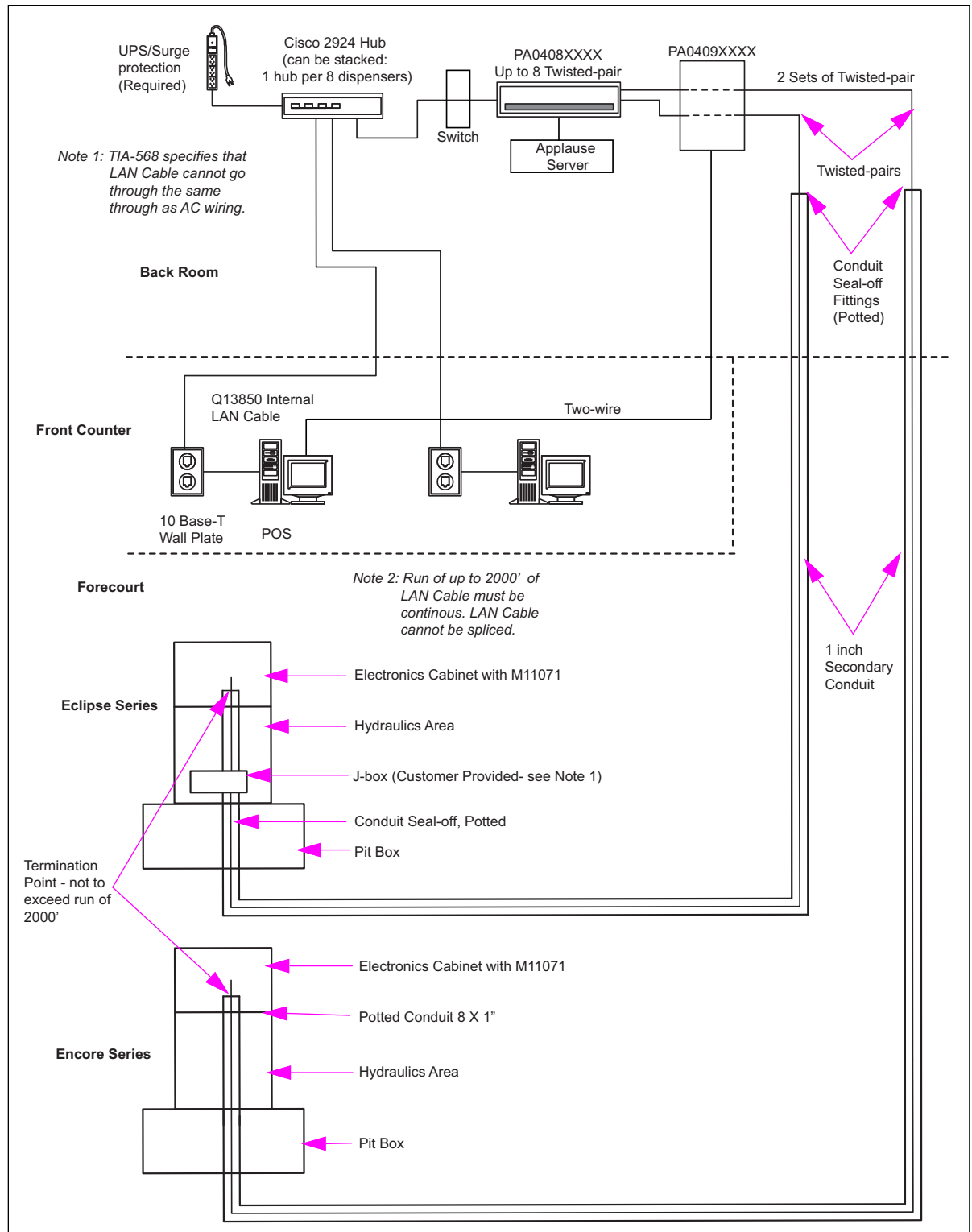

Figure 10-6: Applause with Pump Data on Same Wire



Grounding

Grounding requirements are as follows:

- NFPA 70 requires connecting the following to the system ground:
 - Consoles
 - Pumps and dispensers
 - STP
 - Relay control boxes
 - Circuit breaker panel
 - Electronic leak detectors
- Gilbarco requires connecting each pump/dispenser to an equipment grounding conductor (see Figure 10-7) located in the conduit per NFPA 70, article 250. The following applies to ground conductor:
 - Use of wire no smaller than 12 AWG.
 - Use of wire with green or green and yellow striped insulation.
 - Connection to green grounding screw in the J-box.
 - Grounding the providing power under NFPA 70, article 250.
 - Bonding the neutral bus to an approved grounding electrode.

Figure 10-7: Grounding Plan

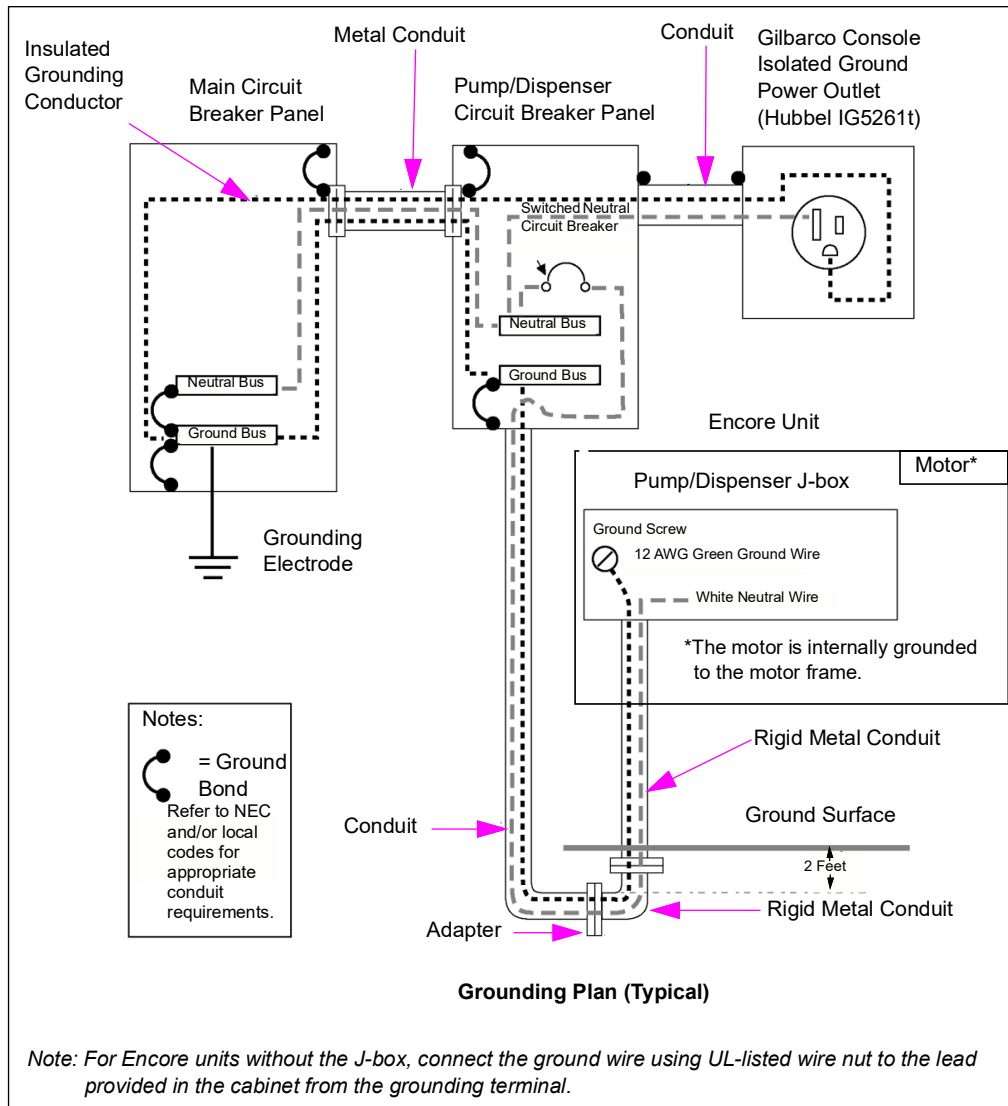

Sealing 'Y' Fittings

'Y' seals are installed in the conduit runs to minimize passage of vapors, gases, or flames from one portion of the electrical installation to another through the conduit. Fittings must be installed in accordance with articles 501-5 and 502-5 of the NEC and fitting manufacturer's instructions.

Gilbarco uses Killark type EY fittings and recommends them or their equivalent for vertical conduit runs. The following sealing directions are for Killark fittings only, and instructions may vary for other manufacturer's fittings. Read and understand all instructions completely before you begin.

To seal 'Y' fittings, proceed as follows:

- 1 Remove the close-up plug (see [Figure 10-8](#)).

Figure 10-8: Typical 'Y' Sealing

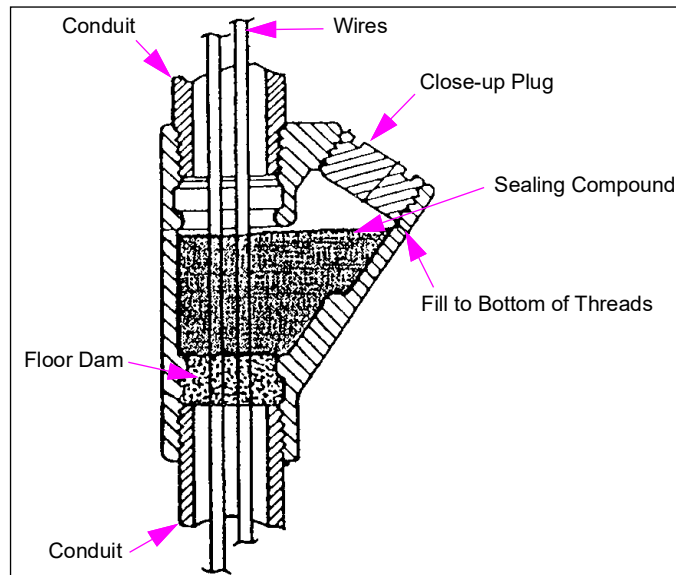

- 2 Separate conductors and fill the conduit in and around conductors using Killark type "PF" packing fiber to make a floor dam to hold the fluid sealing compound.
Note: Floor dam must be even with the conduit stop in the lower hub of the fitting. Ensure that the conductor insulation is not damaged. Force pack between conductors and hubs, pushing any shreds of packing fiber away from conductors to prevent leakage path.
- 3 Use only Killark type "SC" sealing compound with Killark fittings, and do the following:
 - a Use a clean mixing vessel for every batch of sealant.
 - b Mix the compound at the rate of 3 parts compound to 1 part water by volume.
 - c Sprinkle the compound in water while stirring, until a thick paste is formed.
 - d Do not mix more compound than can be used in 15 minutes.
 - e Continue mixing for at least 3 minutes, until consistency is just fluid enough to pour slowly, like thick gravy (not watery).

- 4 Slowly pour the fluid compound till it fills the bottom of the close-up plug threads.
Note: Be careful to pour slowly, to avoid trapping air bubbles in the seal.
- 5 Immediately wipe off any spilled compound and close the seal with a close-up plug.
Note: Initial setting of the sealing compound will occur within 30 minutes. Compound requires a minimum of eight hours above 32 °F (0 °C) to develop sufficient strength to withstand explosion pressures.

Plumbing Requirements

Fluid Handling Components for DEF

Stainless steel 304 or 316, certain plastics like High Density Polyethylene (HDPE), and certain elastomers are the only acceptable materials for parts that store or come in contact with DEF. Verify with the manufacturers if materials of their plumbing components are compatible with mildly corrosive DEF for the environmental and operational conditions experienced by DEF dispensers.

DEF freezes at 12 °F (-11 °C). Precautions must be taken to prevent freezing of the fluid if the environment where the dispenser is installed is likely to induce freezing. Precautions include insulation and heat tracing. All installed components must comply with UL class 1 division 2 requirements. If insulation is used, exercise care to prevent any gaps in coverage as freezing and damage can occur.

If DEF lines are installed above ground and/or in the fuel station canopy, effective means of air elimination must be applied to prevent accuracy issues. Accuracy issues arise due to the air entrained in the fluid flow.

If DEF lines are installed above ground and/or in the fuel station canopy, exercise care to prevent solar loading from heating the fluid in the pipes. This condition can also present accuracy issues.

Shut-off valves must be provided on the inlet line upstream of each dispenser, to allow for individual servicing.

Recommended Hose Material for DEF

The hose material used with DEF units must conform to the following:

- Material must be compatible with the DEF being dispensed (32.5% urea solution).
- Material must be compatible with the environmental conditions being experienced by the hose plumbing.
- Material must withstand the maximum operating pressure, including the hydraulic shock that may be experienced during operation.

Skid Mounted Tanks for DEF Dispensers

For skid mounted tanks for DEF dispensers ensure that you read, understand, and follow any manufacturer-supplied installation documents.

Acceptable Pipe Material for DEF

Stainless steel grade SS 304 or 316 and HDPE are the only acceptable pipe materials for DEF.

Certain elastomeric hoses are acceptable for use with DEF units. Consult the hose manufacturers for recommendations for safe use under the operational, pressure, and environmental conditions that will be experienced by the hose.

Pipe Installation

For Installation of Underground Liquid Storage Systems (Chapter 9), refer to “PEI Publication RP100 Recommended Practices and for Installation of Above-ground Storage Systems”; for Motor Vehicle Fueling, refer to “PEI Publication RP200 Recommended Practices”.

Product inlet pipes and vapor pipes for Gilbarco pumps/dispensers vary in location between models. Product piping order differs from blenders to previous Advantage models. See model-specific footprint before installing the pipes.

- Check national, state, and local regulations for installation of the pipe system.
- Use containment system as required by national, state, and local regulations.
- Below the unit, use UL and code-approved flexible pipe (constructed of UL-approved pipe material and UL-approved fittings).

Note: Some local regulatory agencies do not allow the use of a galvanized piping component when diesel is involved. Consult local regulators. Also, galvanized piping is not usable for certain alternative fuels, such as E25/E40 and E85, or biodiesel.

IMPORTANT INFORMATION

Gilbarco supplies galvanized **Tubing** (not pipe). However, no zinc or galvanizing is present on the inner circumference of any tubing or piping supplied by Gilbarco.

- Use a 1-1/2-inch pipe for riser-to-pump or dispenser.
- Alternative fuels, such as E25/E40 and E85, may require special piping materials or components. Consult the manufacturer to determine whether the piping material is compatible with the fluid being used.
- Use 2-inch risers on Ultra-Hi units that use a 2-inch shear valve.
- Leak detectors may not detect leaks reliably in plumbing between master and satellite Ultra-Hi units. Secondary containment and likely specialized leak detection equipment is required. Consult codes.

Pipe Size

The required pipe size depends on the number of units sharing lines, size of the STPs (dispensers only), and length of the run. Following guidelines must be followed:

Pumps (Standard Flow)

Use new pipes of 2, 2-1/2, or 3 inches.

- Pipe of 2 inches for runs up to 50 feet to a single pump.
- Pipe of 2-1/2 or 3 inches for longer runs up to 75 feet to a single pump with maximum lift condition.

Note: A dedicated line is recommended to supply each self-contained pump.

Pumps (High Flow)

Use new pipes of 3, 3-1/2, or 4 inches.

- Pipe of 3 inches for runs up to 50 feet to a single pump.
- Pipe of 3-1/2 or 4 inches for longer runs up to 75 feet to a single pump with maximum lift condition.

Note: A dedicated line is recommended to supply each self-contained pump.

Dispensers (Standard Flow)

Use new pipes of 2, 2-1/2, or 3 inches.

Notes: 1) If the distance from the STP to the farthest dispenser is 200 feet or less, use a pipe of 2 inches.

2) If the distance exceeds 200 feet, use a pipe of 2-1/2 or 3 inches to the first dispenser and a pipe of 2 inches along the rest of the way. Trunk lines supplying multiple dispensers must be larger and must be sized to provide low pressure drops for an anticipated flow rate. Use of smaller size pipes may result in lower flow rates than normally accepted.

Dispensers (High Flow)

Use new pipes of 3, 3-1/2, or 4 inches.

Notes: 1) If the distance from the STP to the farthest dispenser is 200 feet or less, use a pipe of 3 inches.

2) If the distance exceeds 200 feet, use a pipe of 3-1/2 or 4 inches to the first dispenser and a pipe of 3 inches along the rest of the way. Trunk lines supplying multiple dispensers must be larger and must be sized to provide low pressure drops for an anticipated flow rate.

Dispensers (Ultra-Hi High Gallon)

Use new pipes of 3 or 4 inches.

Notes: 1) If the distance from the STP to the farthest dispenser is 75 feet or less, use a pipe of 3 inches.

2) If the distance exceeds 75 feet, use a pipe of 4 inches to the first dispenser and a pipe of 3 inches along the rest of the way. Trunk lines supplying multiple dispensers must be larger and must be sized to provide low pressure drops for an anticipated flow rate.

Check Valves (Used on Pumps and Ultra-Hi Units only)

For information on installing the check valves for pumps, refer to “PEI publication RP100” and manufacturer’s installation instructions. Install the check valve as close as practically possible to the suction unit. It must be gravity-activated with minimal, or no spring load. Check valves for use internal to the pumping unit are available from Gilbarco as an order entry item.

Ensure that there is only one check valve in each dedicated line (preferred method). Use of multiple check valves can restrict flow and cause cavitation, resulting in significant flow rate reductions. If installation necessitates placing more than one unit on a single dedicated product line, then check valves must be placed at each pumping unit. Check valves must be accessible for service.

The inlet check valve for Ultra-Hi units is required for accuracy in metering fuel. Use a factory-installed option or installation-installed check valve of low pressure drop.

Notes: 1) Components must be compatible with the fluid type being dispensed. For more information, consult the concerned manufacturer.

2) Pumping units do not come with Inlet Check valves and are not interchangeable between M04920B003 and M09593A102. Order check valves separately. For units sharing inlets, both pumping units are required to have internal Check Valve (M09593K207 GPU+ Inlet Check kit).

Shear Valves (Generally Used on Dispensers only)

Note: For some locations, shear valves are required for pumps.

For Installation of Underground Liquid Storage Systems (Chapter 9), refer to “PEI publication RP100 Recommended Practices and for Installation of Above-ground Storage Systems”; for Motor Vehicle Fueling, refer to “PEI publication RP200 Recommended Practices”. A shear valve (see [Figure 6-8](#) on [page 6-12](#)) is an NFPA 30A required safety device. It closes automatically to stop product flow during a fire or if the dispenser gets knocked off the island. It also provides a means of manually closing inlet pipes.

This page is intentionally left blank.

Appendix: Elevation and Foundation Diagrams

Figure A-1: Encore 300/500 Elevation Diagram

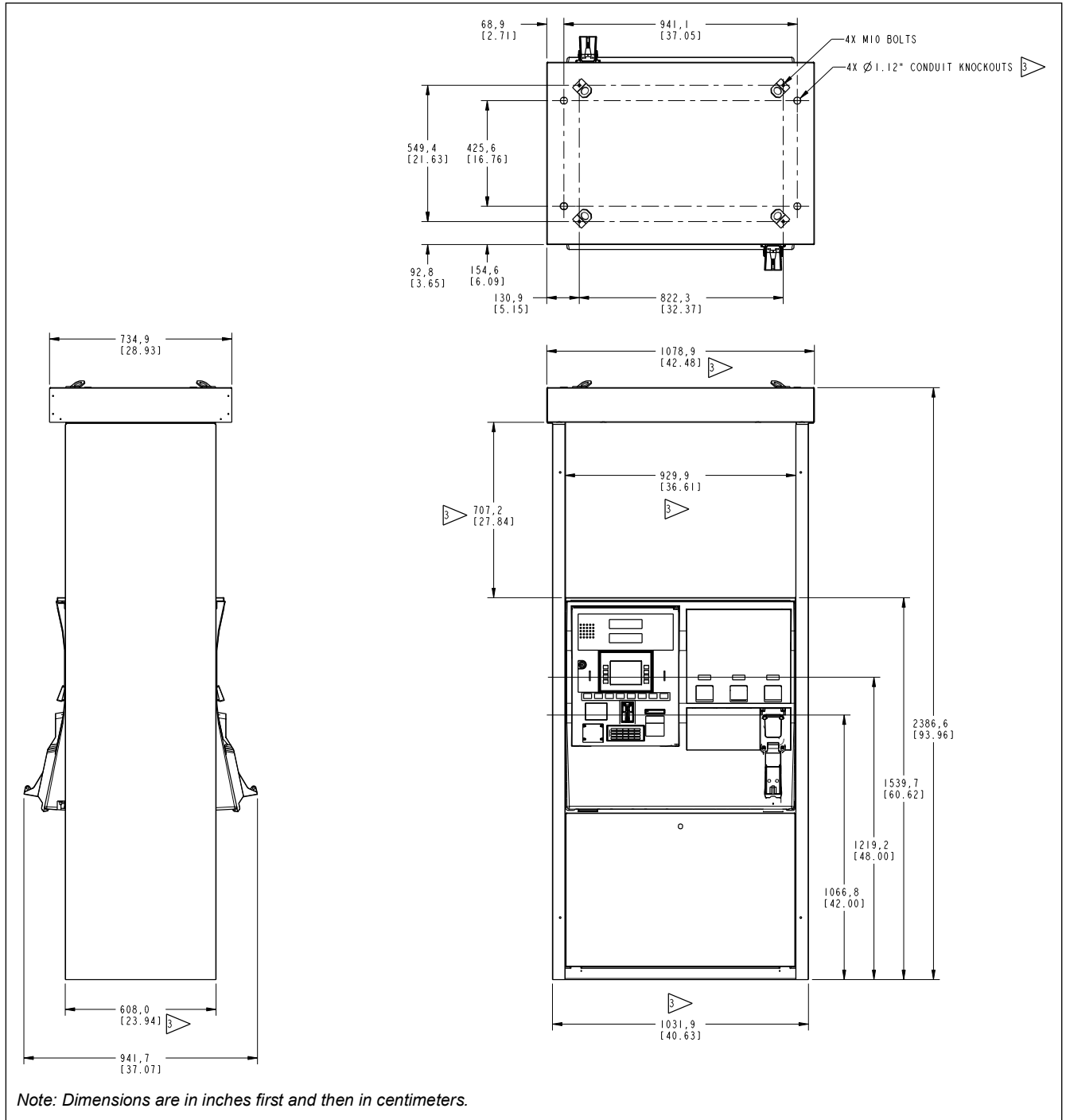

Figure A-2: Encore S E-CIM Mono Elevation Dimensions

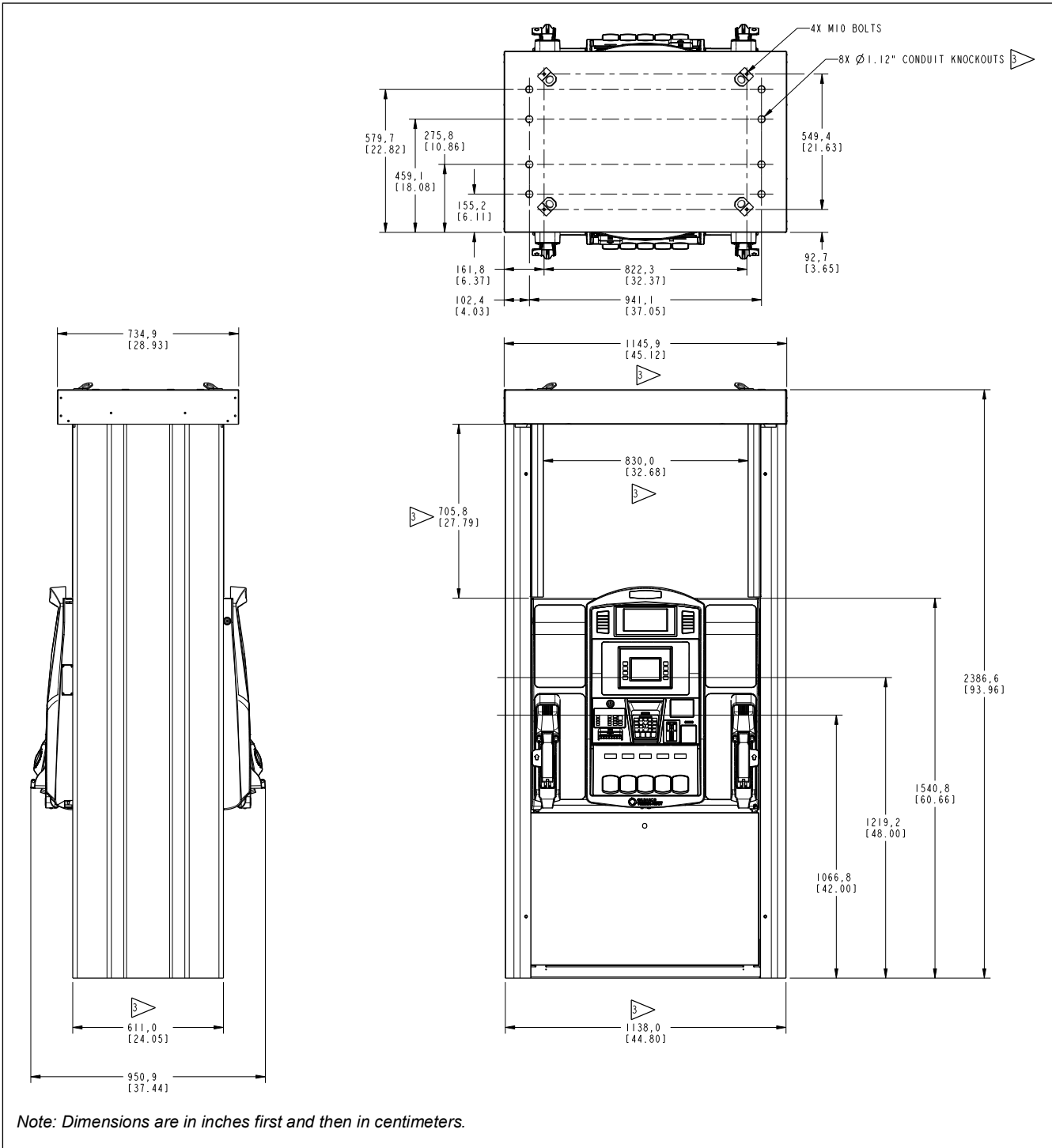

Figure A-3: Encore S E-CIM Color Elevation Diagram

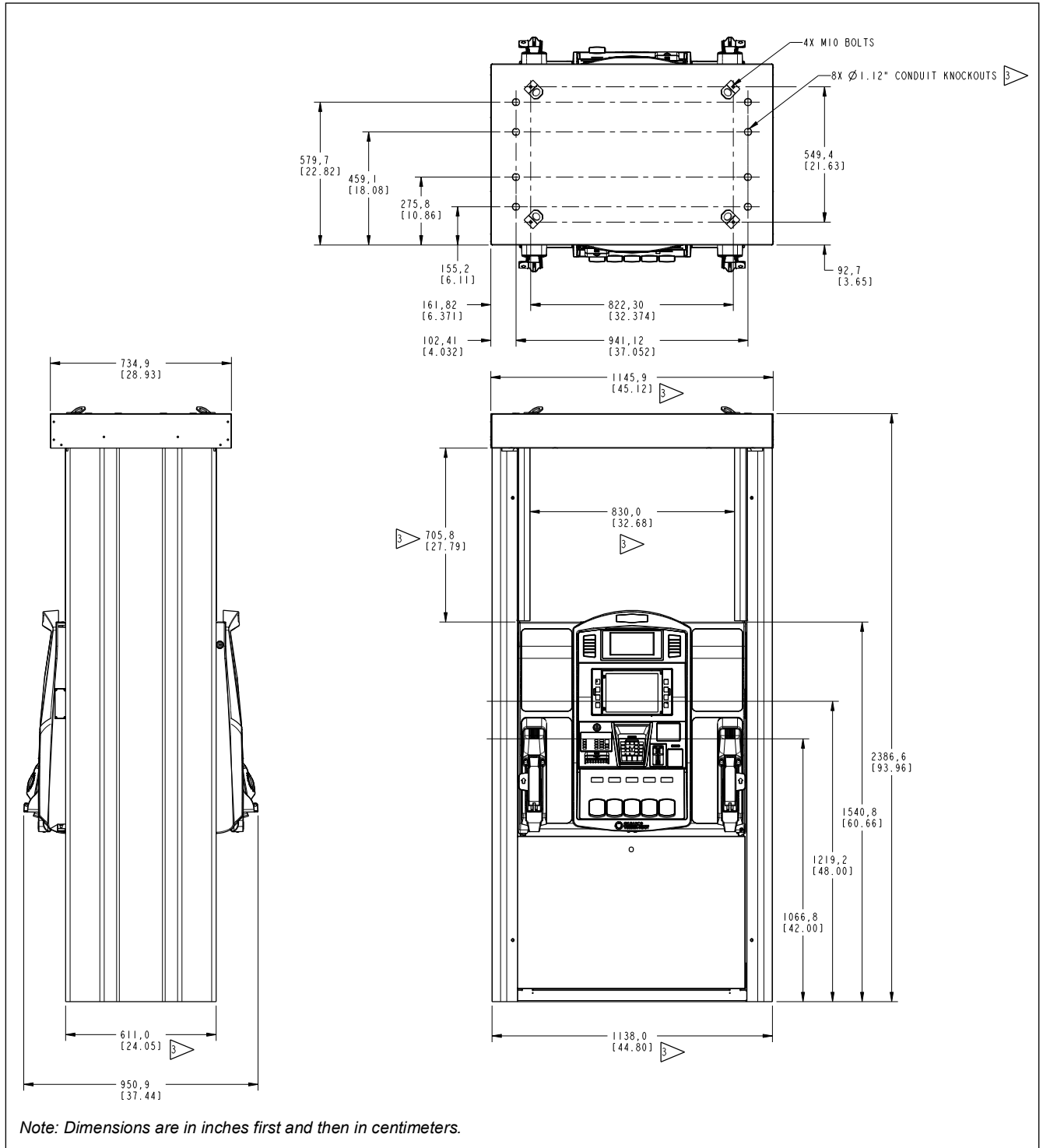

Figure A-5: Encore 700 Elevation Diagram

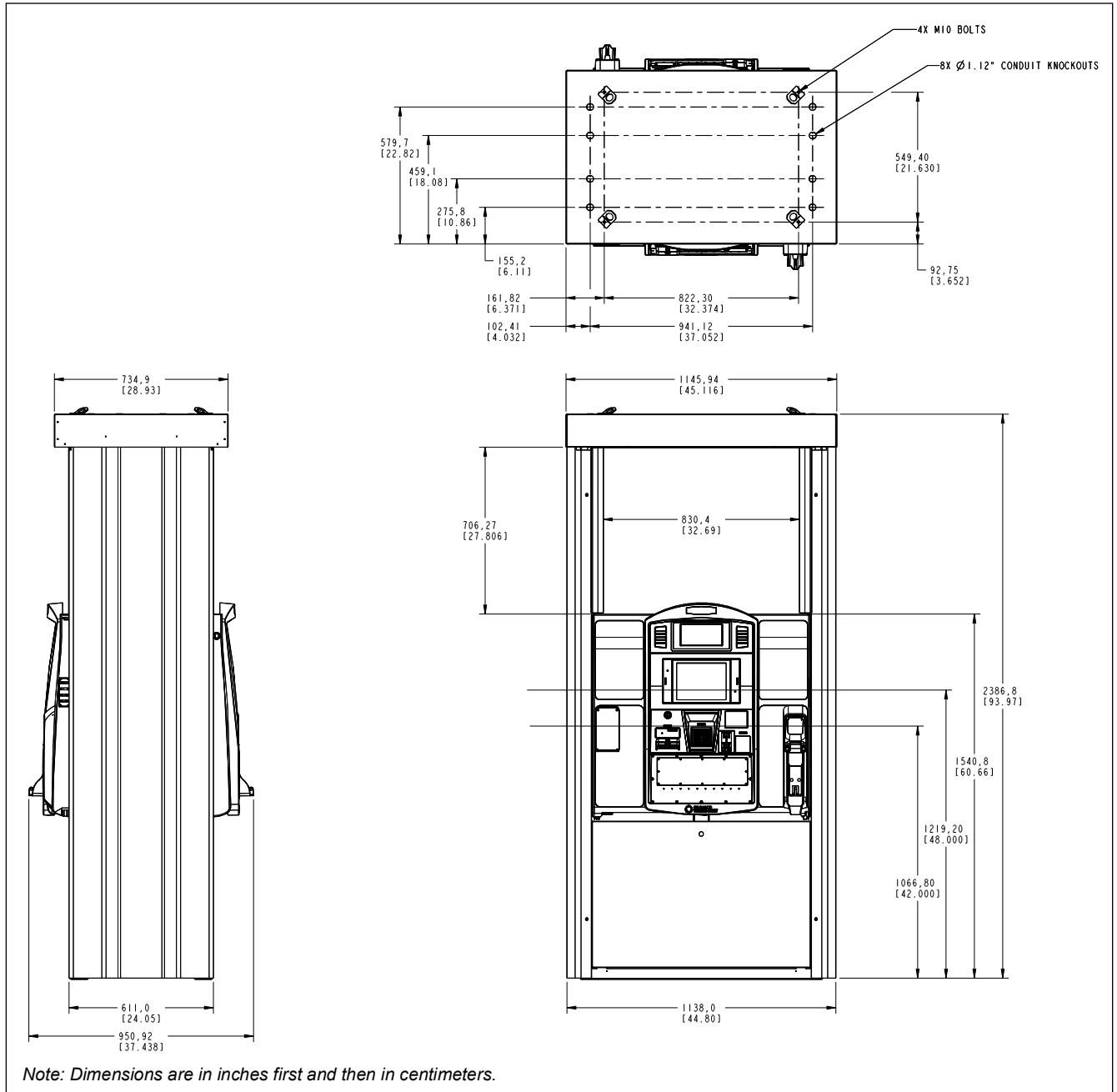

Figure A-6: Encore 700 with Brand View Canopy Elevation Diagram

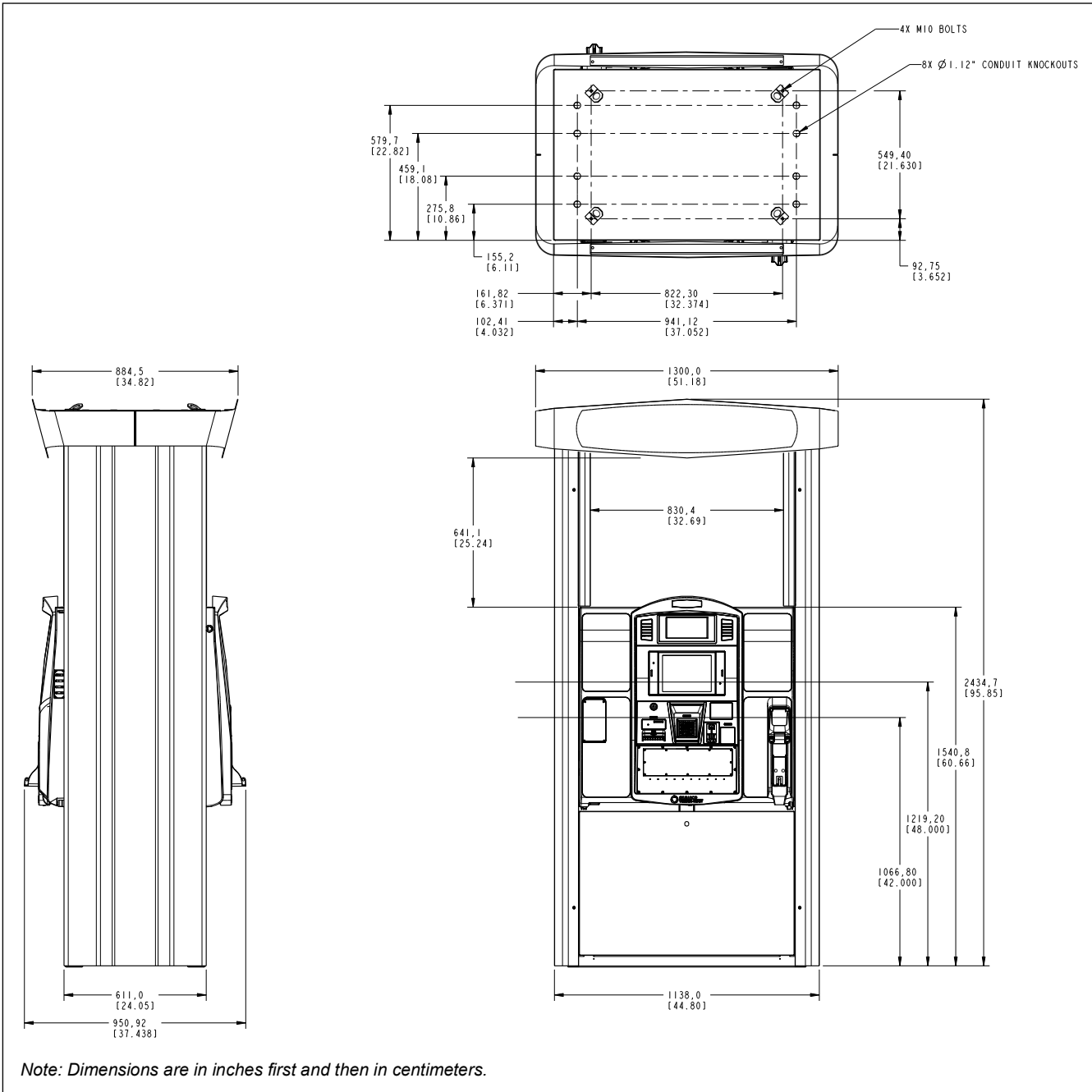

Figure A-7: Encore 700 with Rectangular Canopy Elevation Diagram

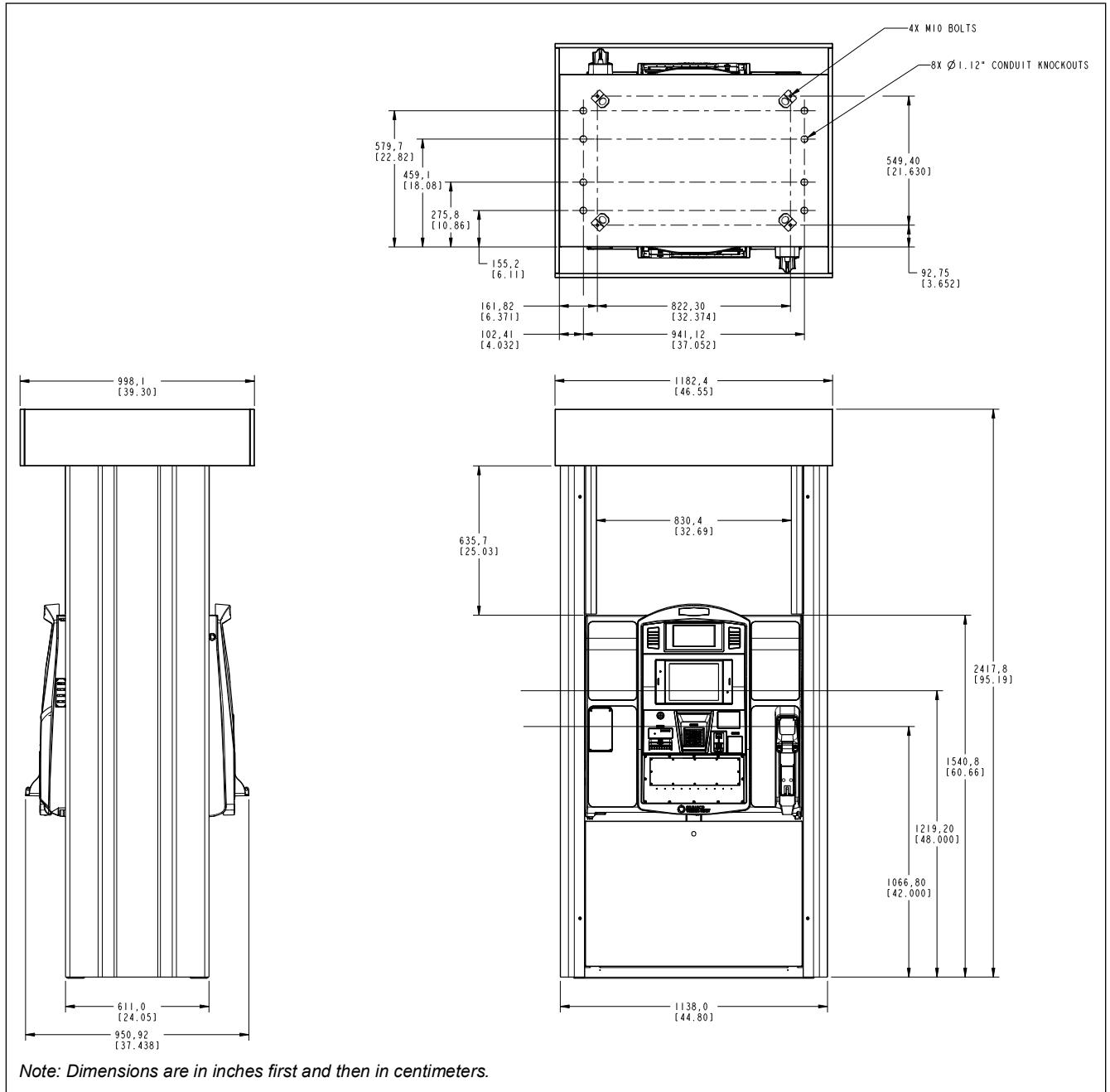

Figure A-8: Encore DEF Right-side Elevation Diagram

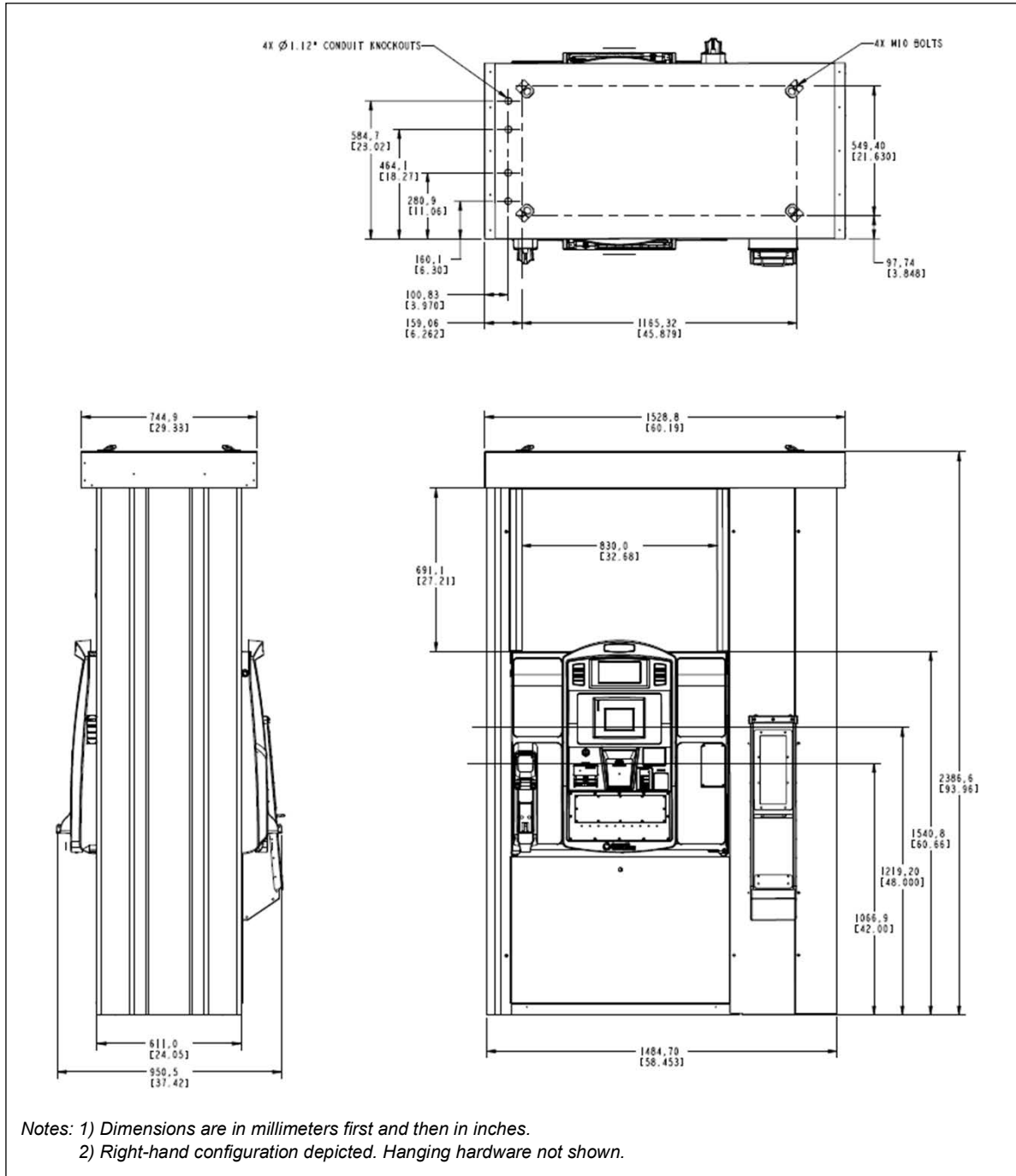

Figure A-9: Encore DEF Left-side Elevation Diagram

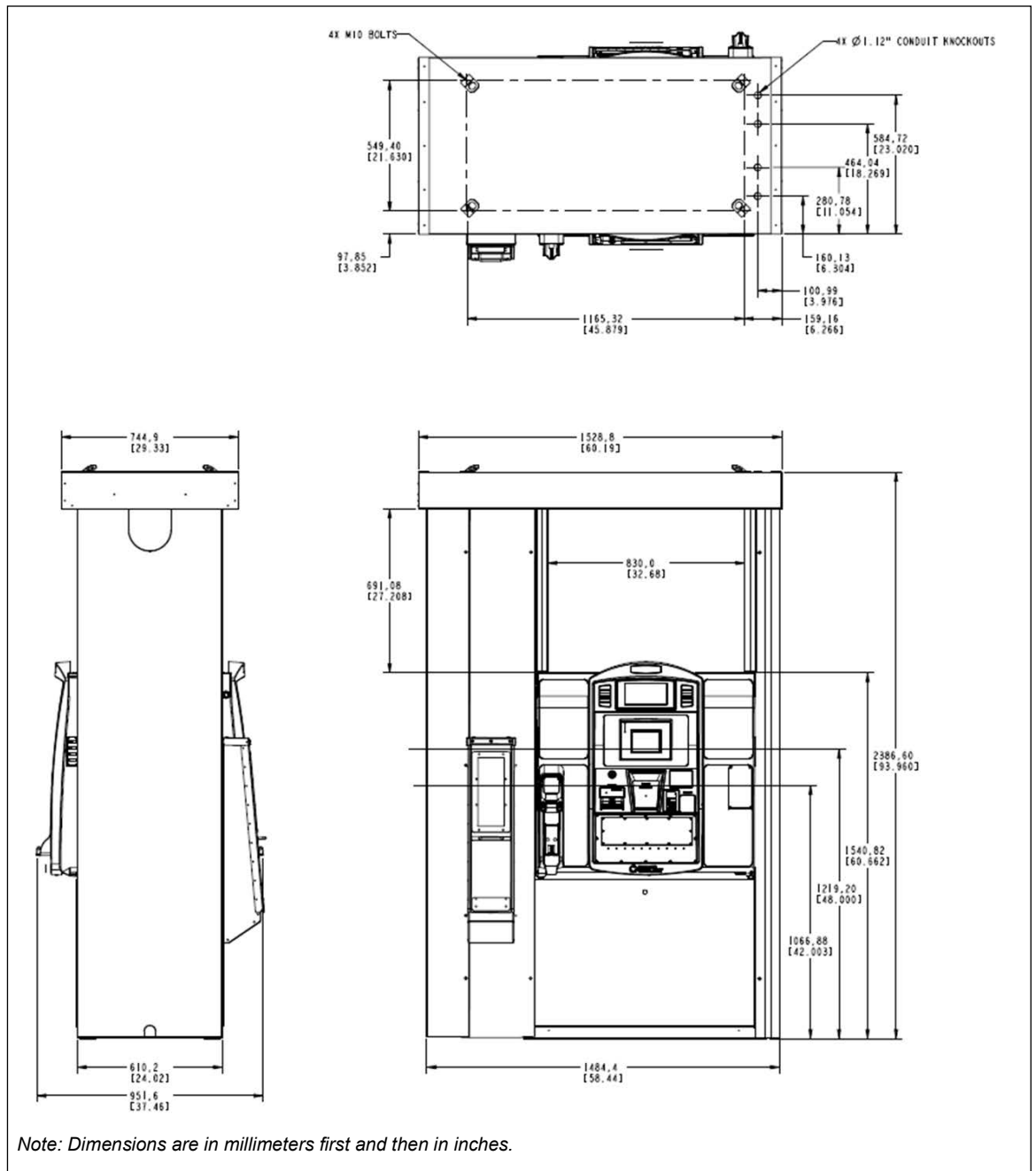

Figure A-10: Encore DEF Right-side with Brand View Canopy Elevation Diagram

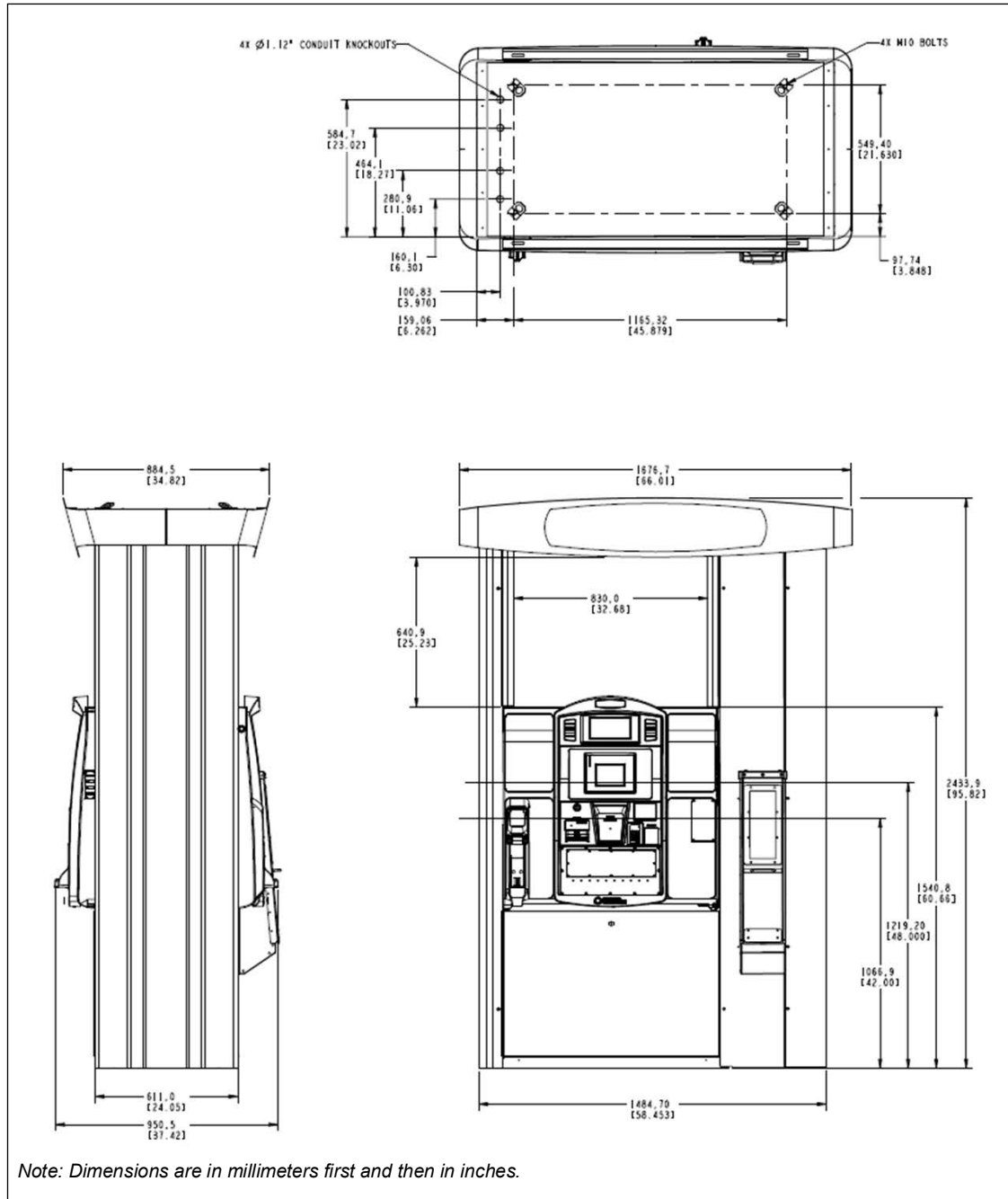

Figure A-11: Encore Foundation Diagrams: 1 of 9 (Field Electric Conduit Placement)

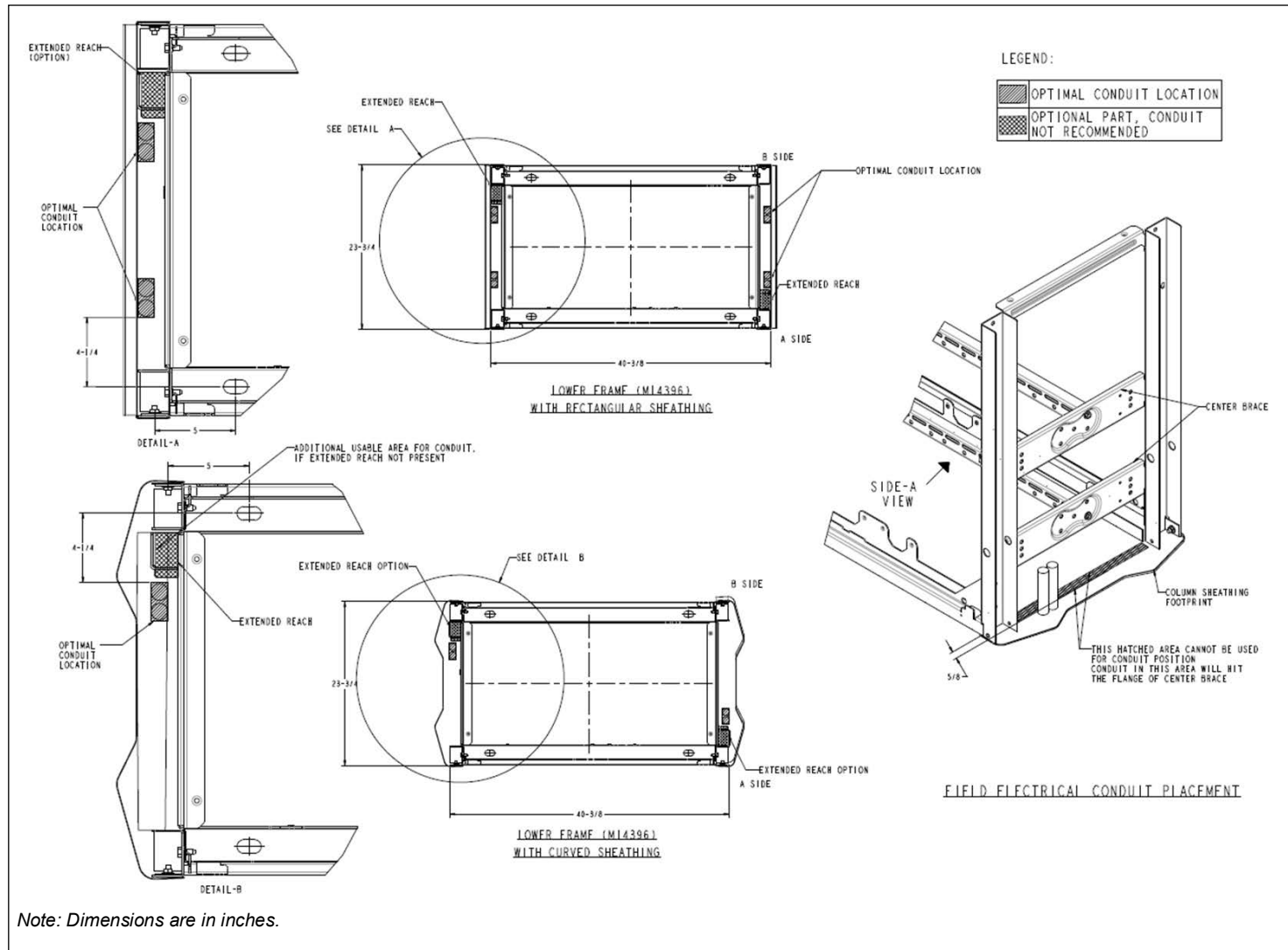
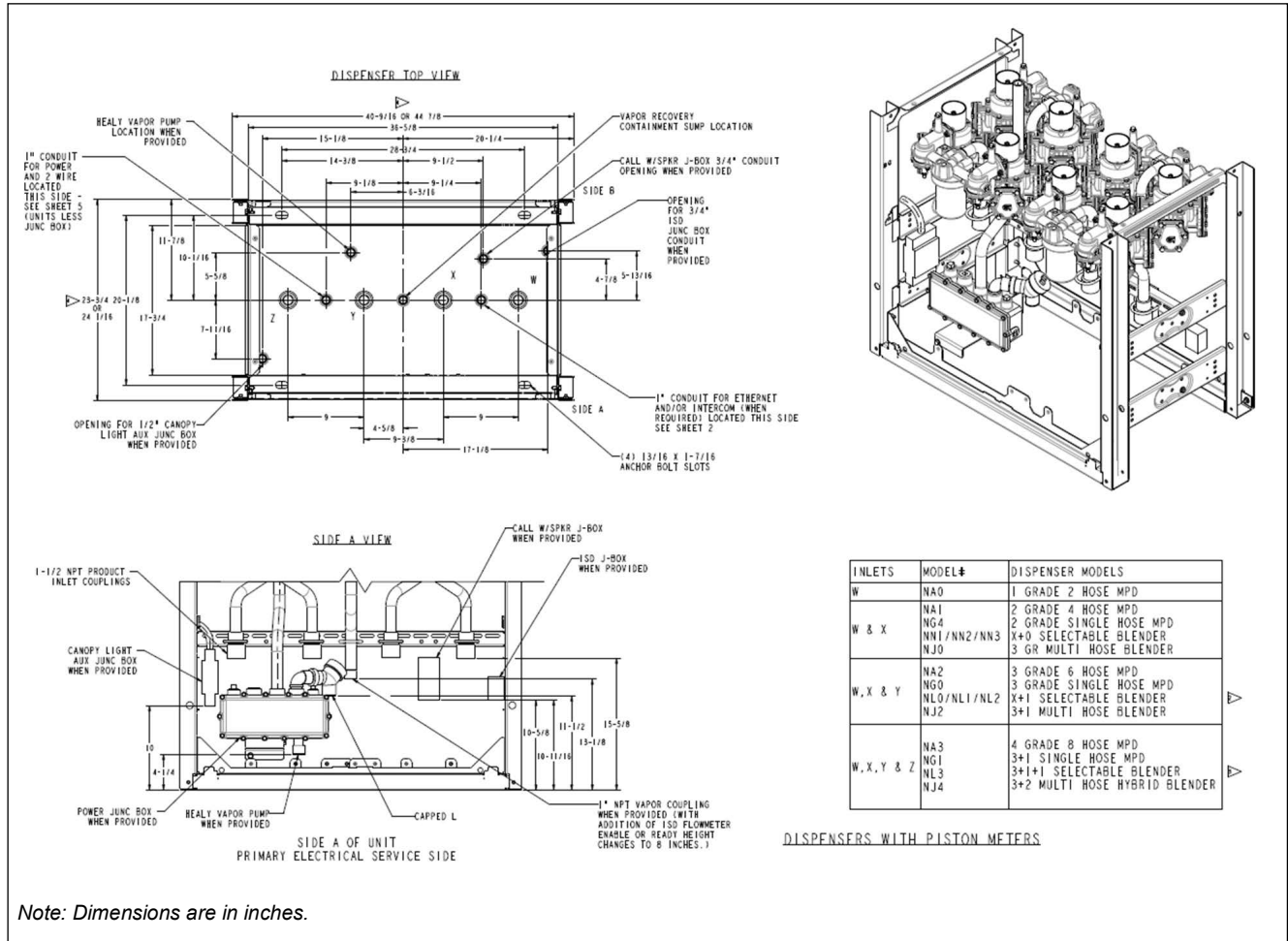
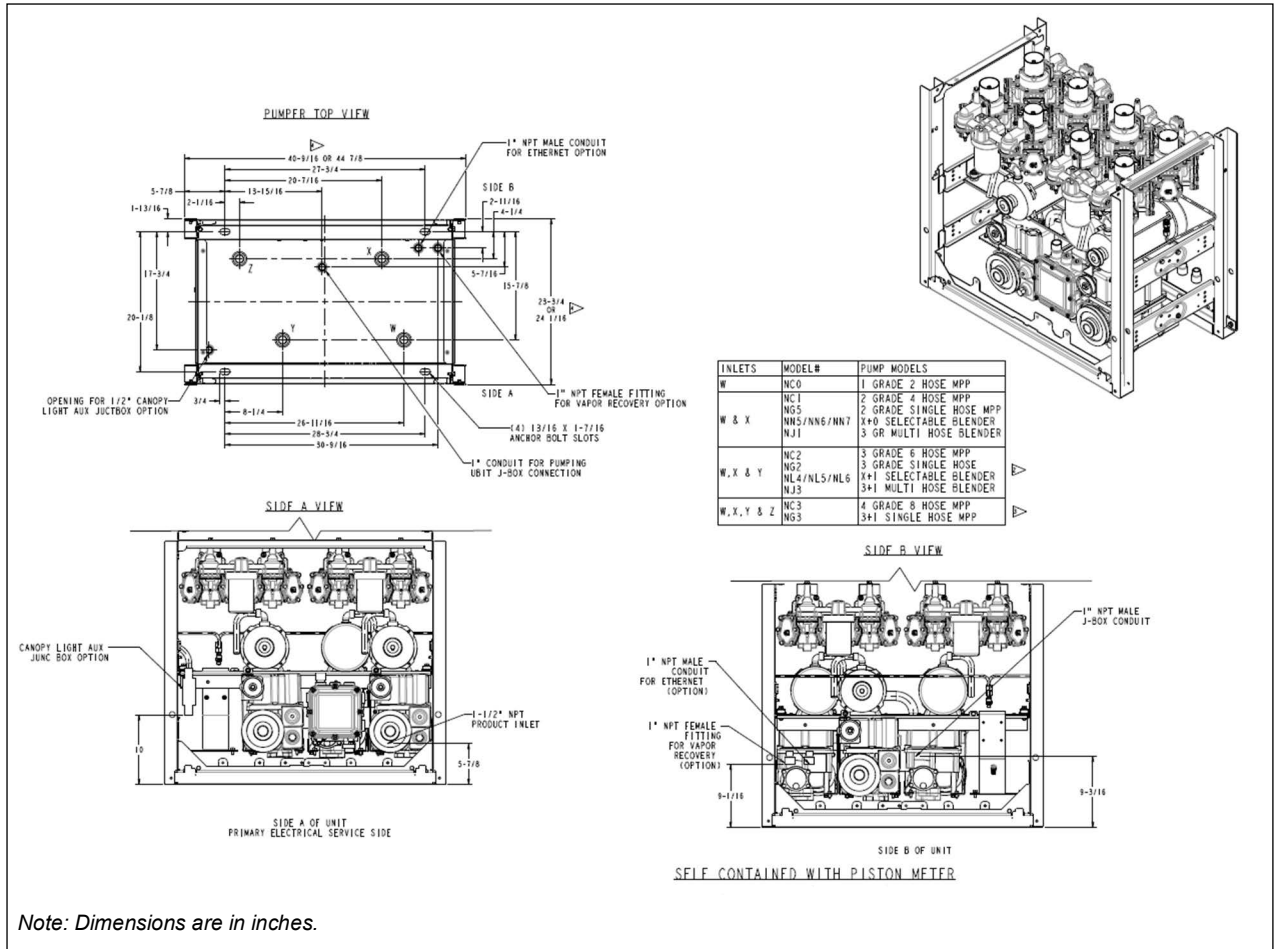

Figure A-12: Encore Foundation Diagrams: 2 to 9 (Dispensers with Piston Meters)



Note: Dimensions are in inches.

Figure A-13: Encore Foundation Diagrams: 3 of 9 (Self Contained with Piston Meters)



Note: Dimensions are in inches.

Figure A-14: Encore Foundation Diagrams: 4 of 9 (Electrical Conduit Layout)

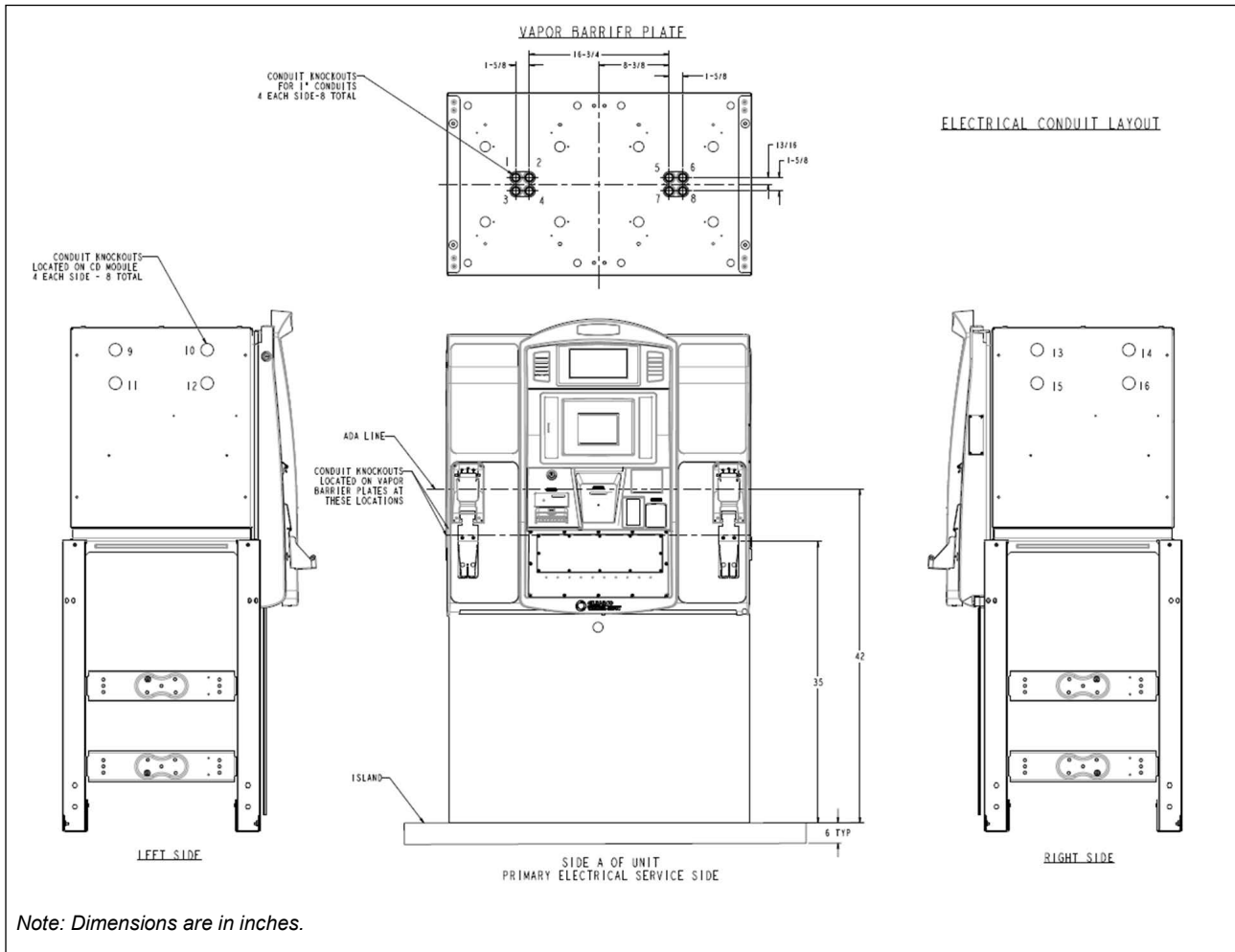
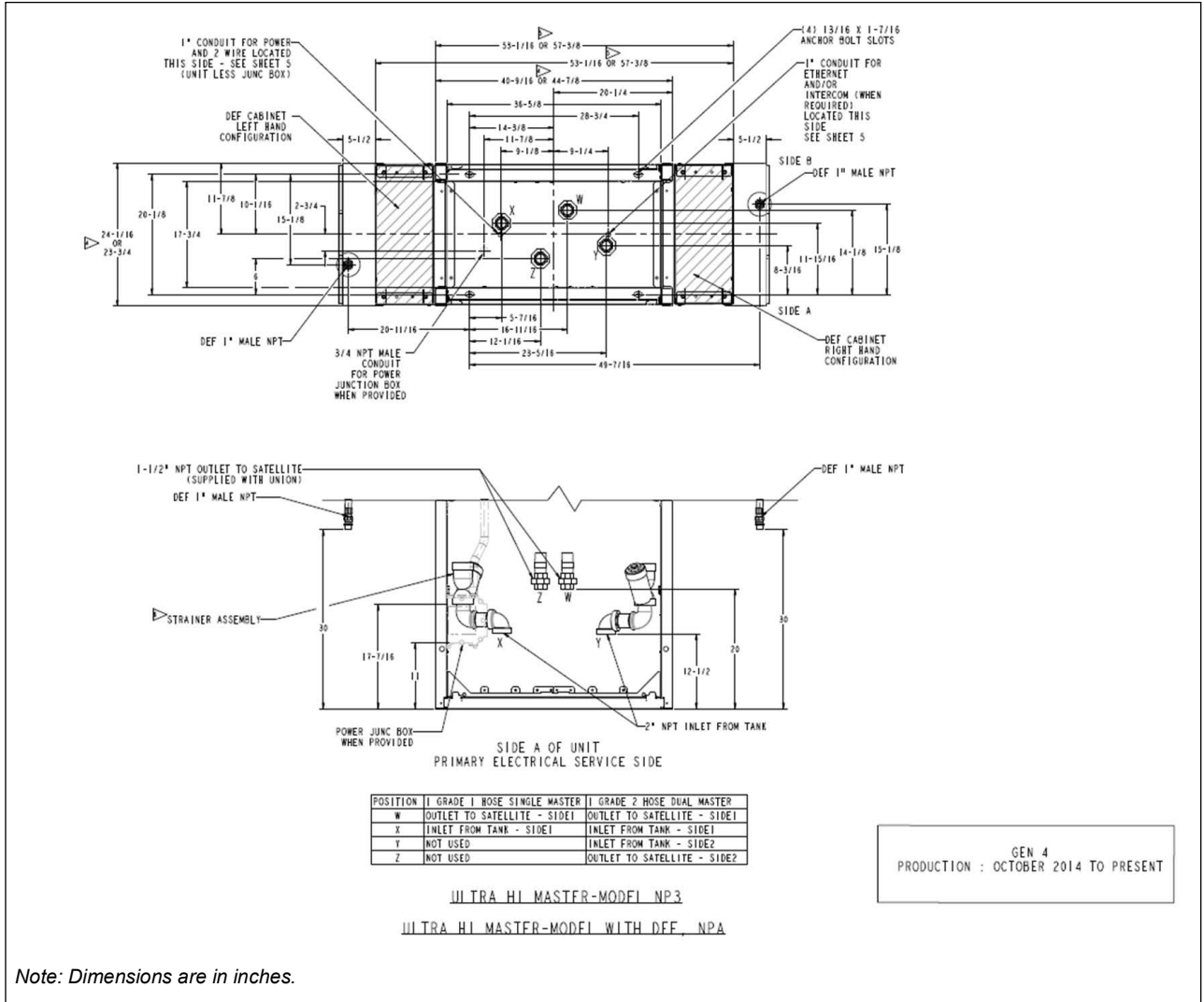
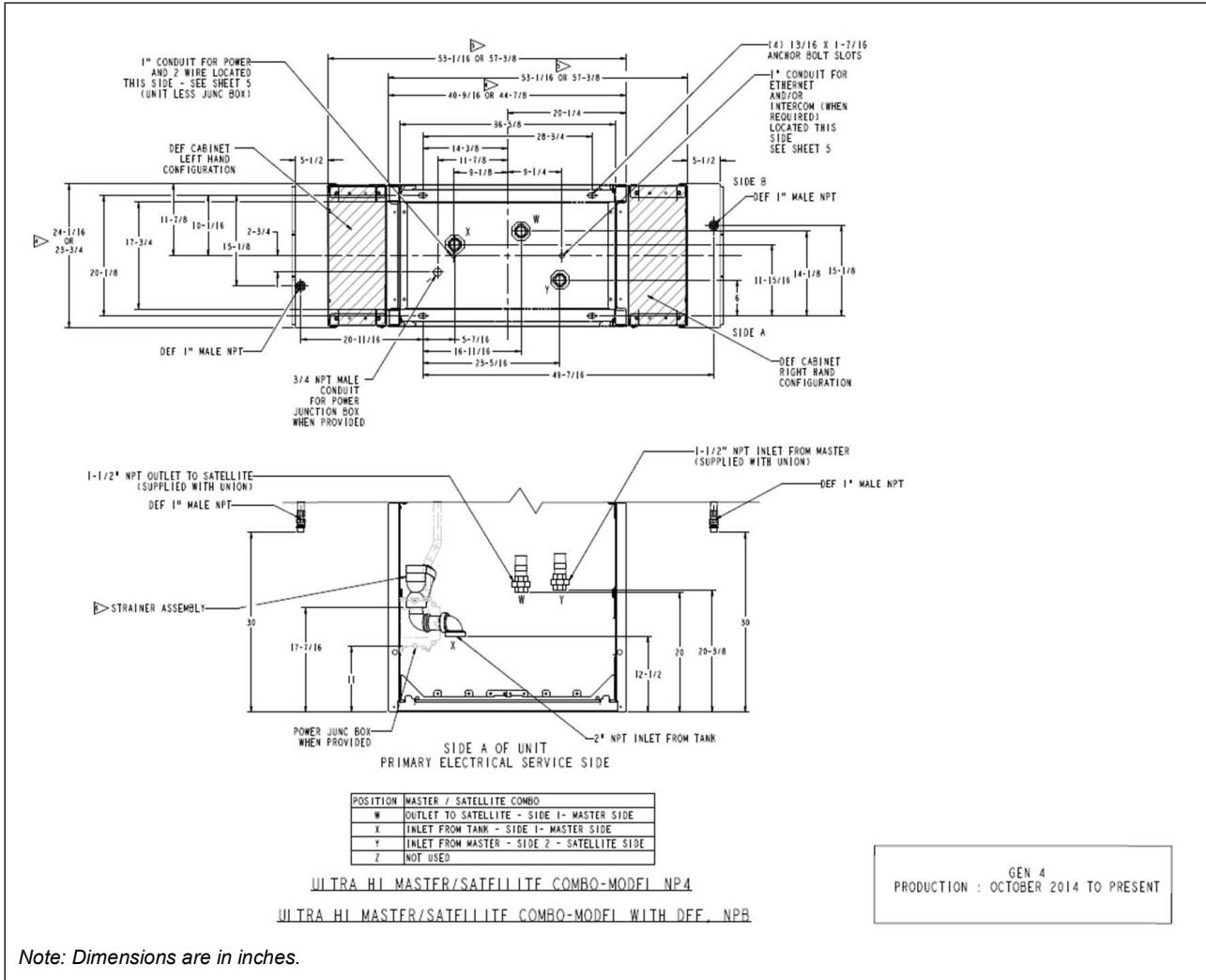

Figure A-15: Encore Foundation Diagrams: 5 of 9 (Encore 500/700 S Ultra-Hi NP3)



Note: Dimensions are in inches.

Figure A-16: Encore Foundation Diagrams: 6 of 9 (Encore 500/700 S Ultra-Hi NP4 and NPB)



Note: Dimensions are in inches.

Figure A-17: Encore Foundation Diagrams: 7 of 9 (Encore 500/700 S Ultra-Hi Satellite NP5 and NP8)

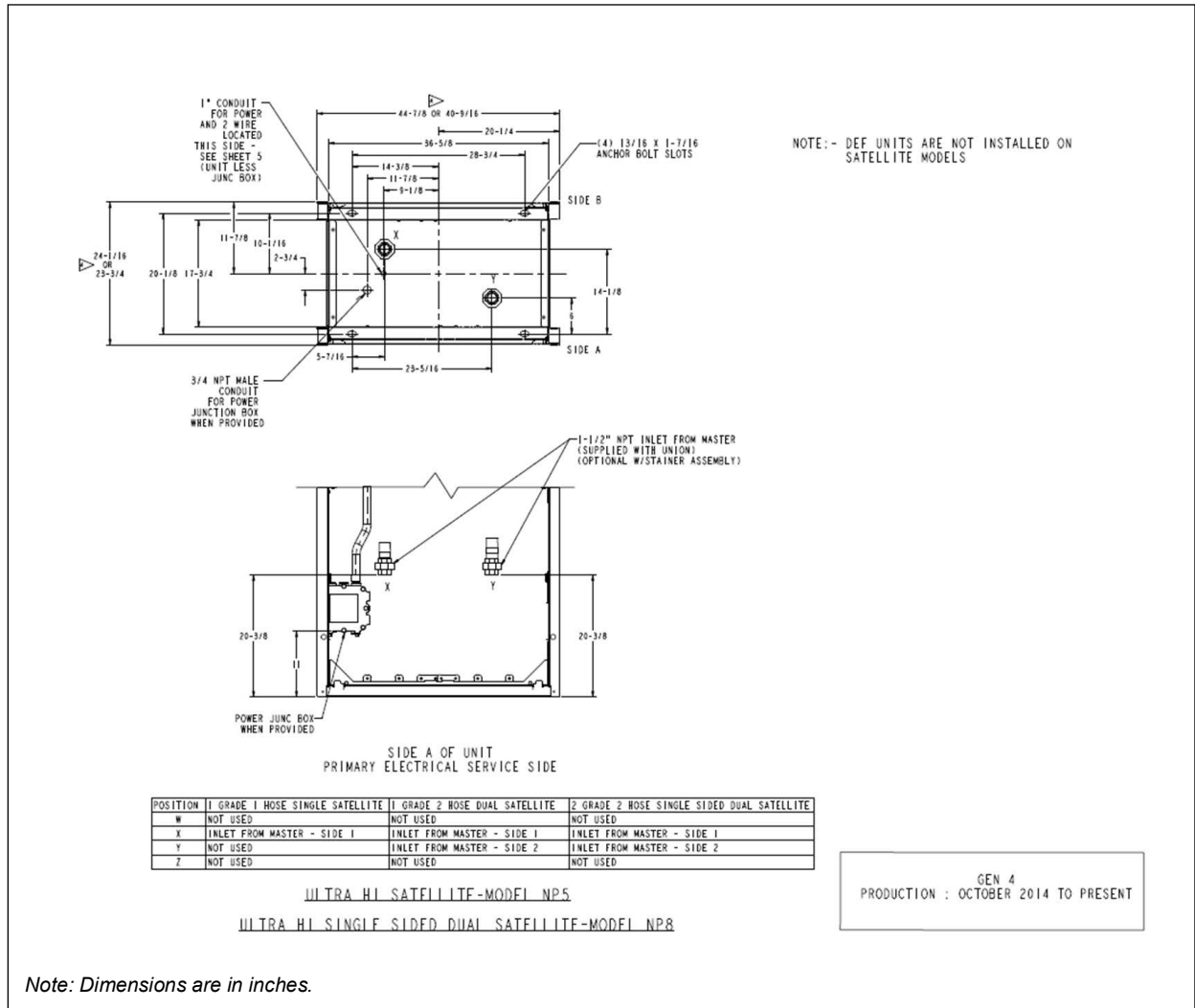

Note: Dimensions are in inches.

Figure A-20: Main Cabinet Conduit Knockouts

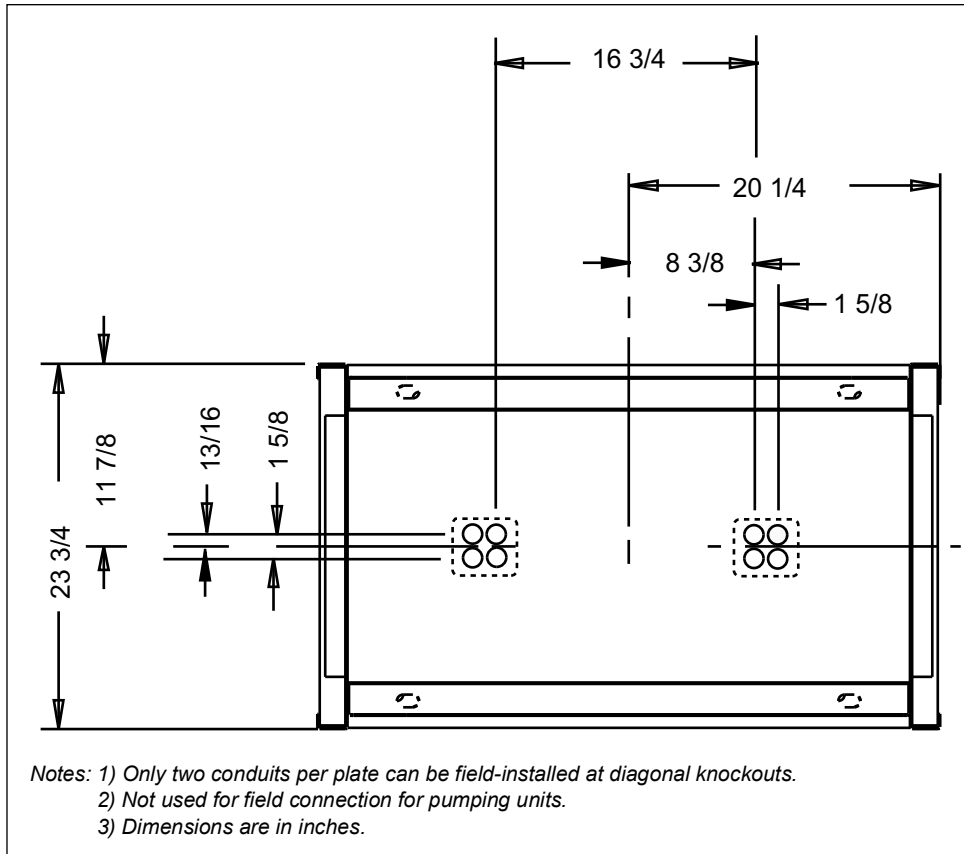

Figure A-21: Encore Elevation Diagram (Encore 550 with SMART Meter)

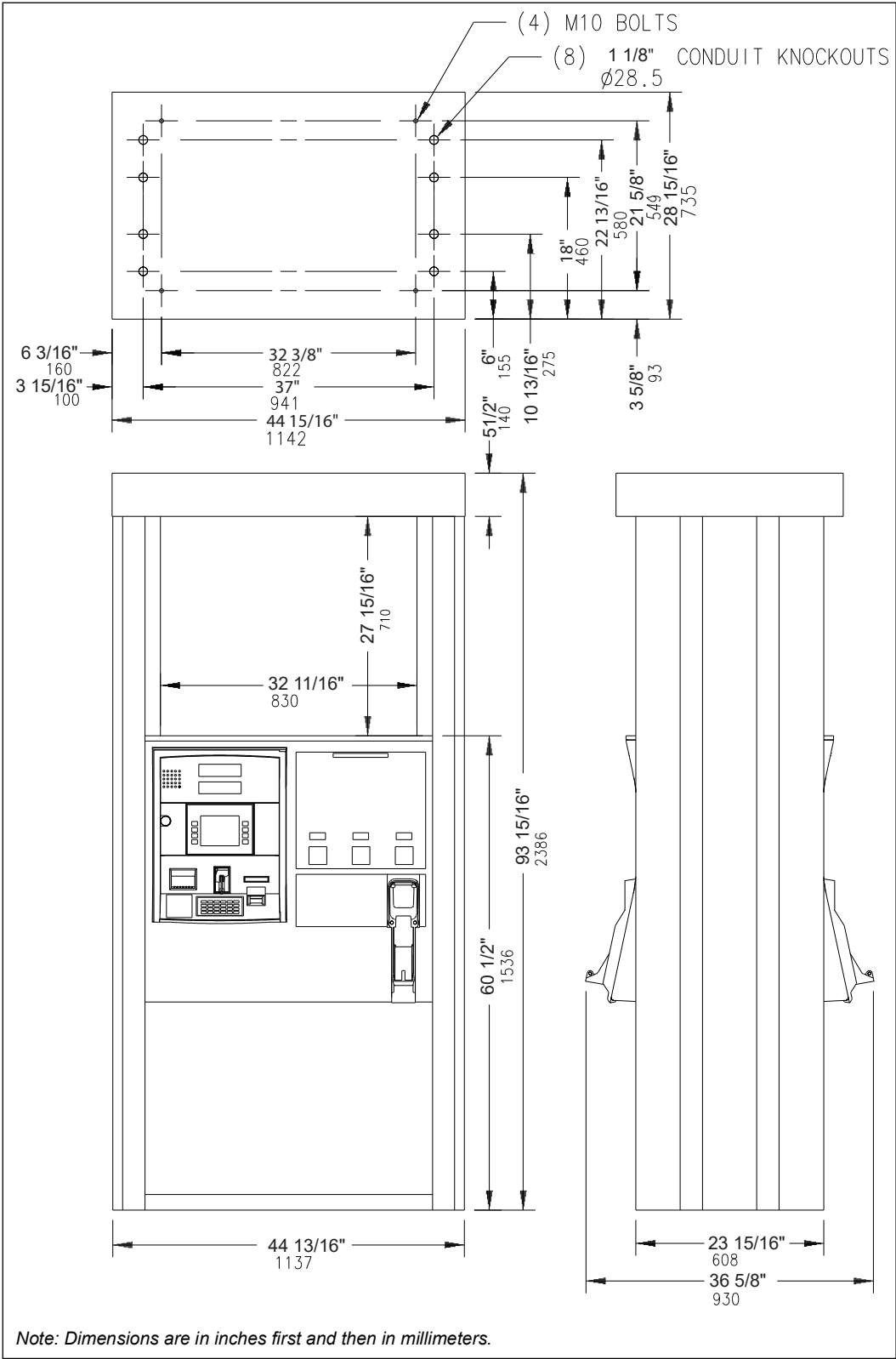

Figure A-23: Healy and In-station Diagnostic Option (Encore 300/500/500 S/700 S/900)

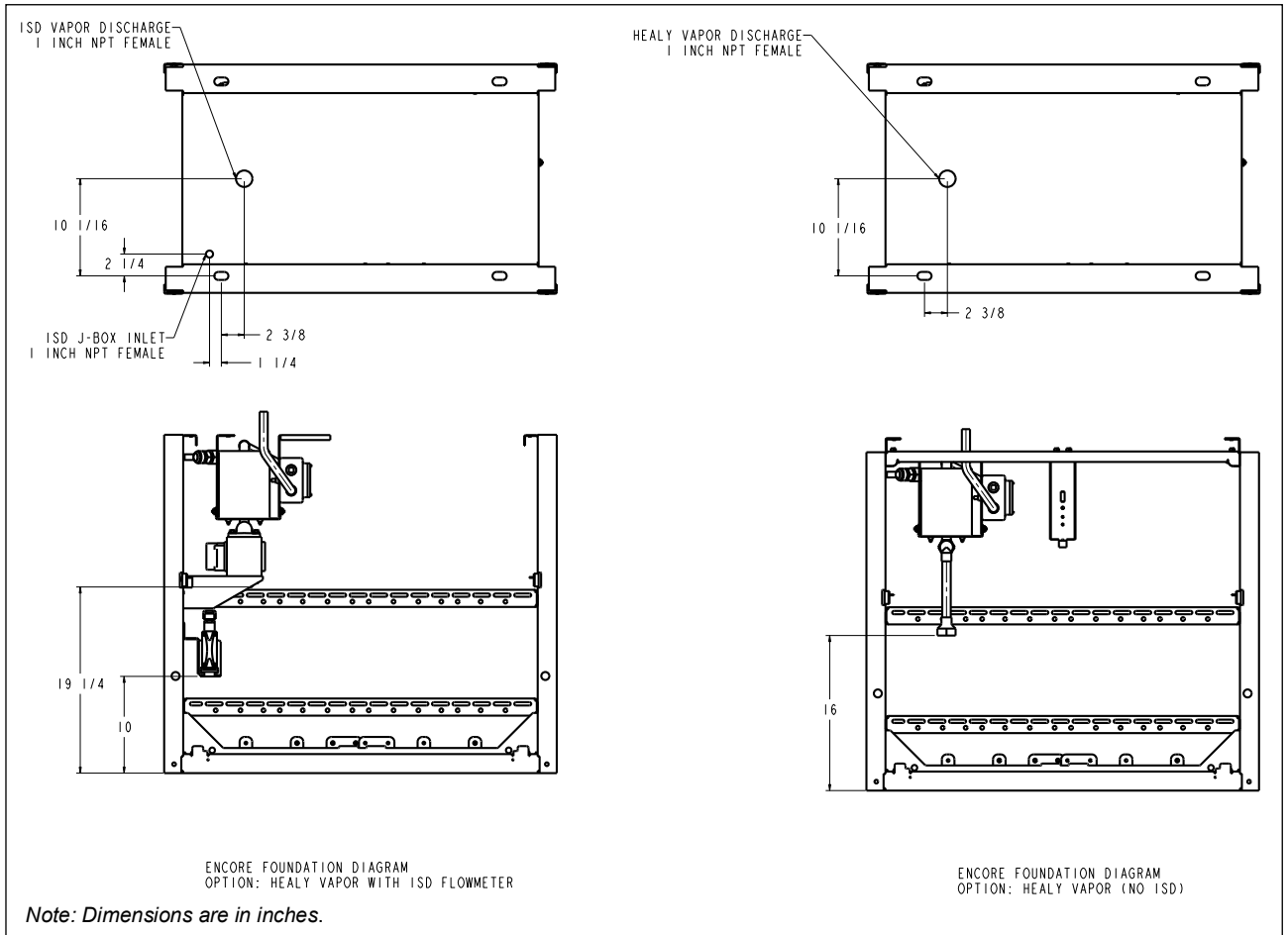

Figure A-24: Encore DEF Only Foundation Diagram

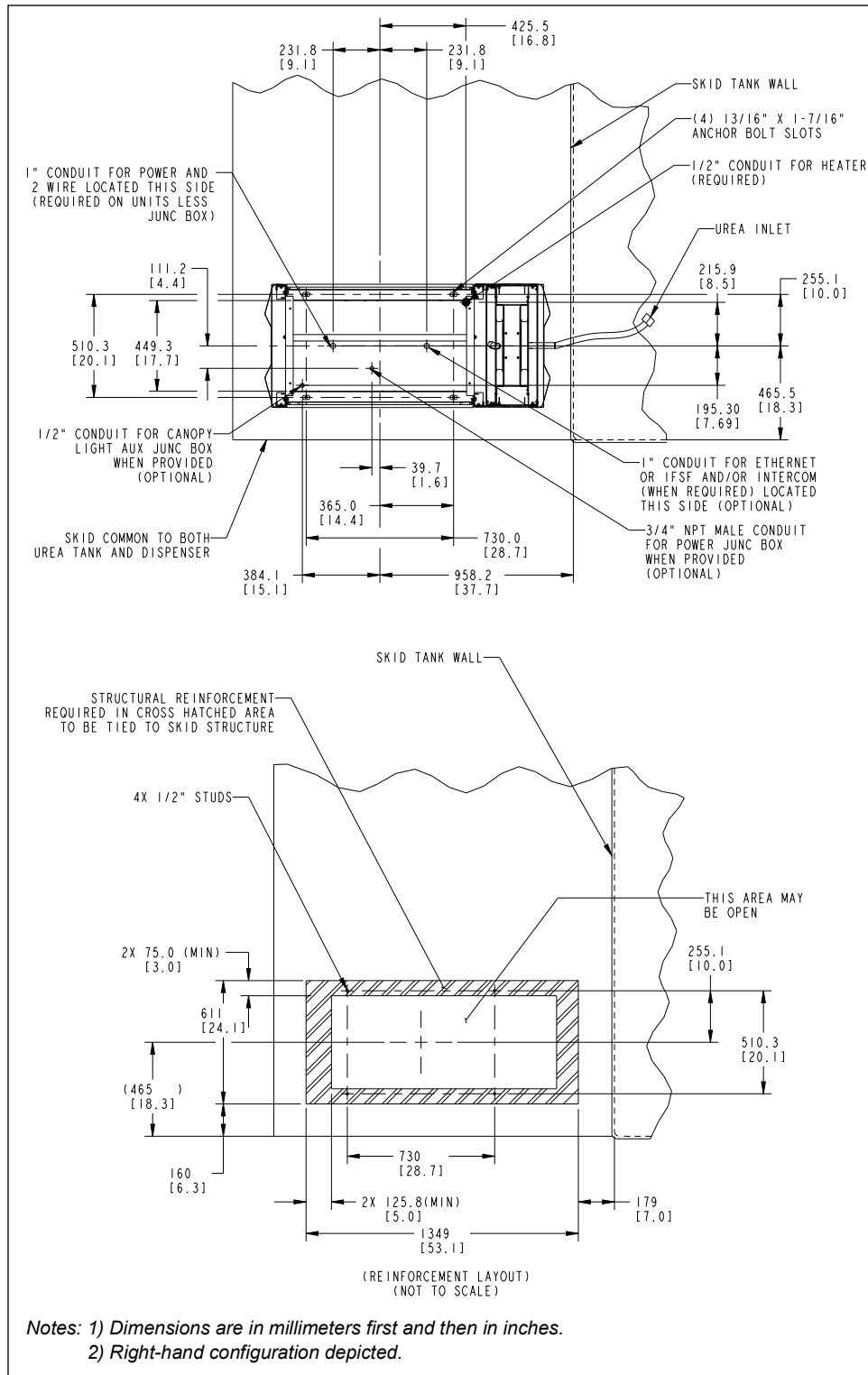
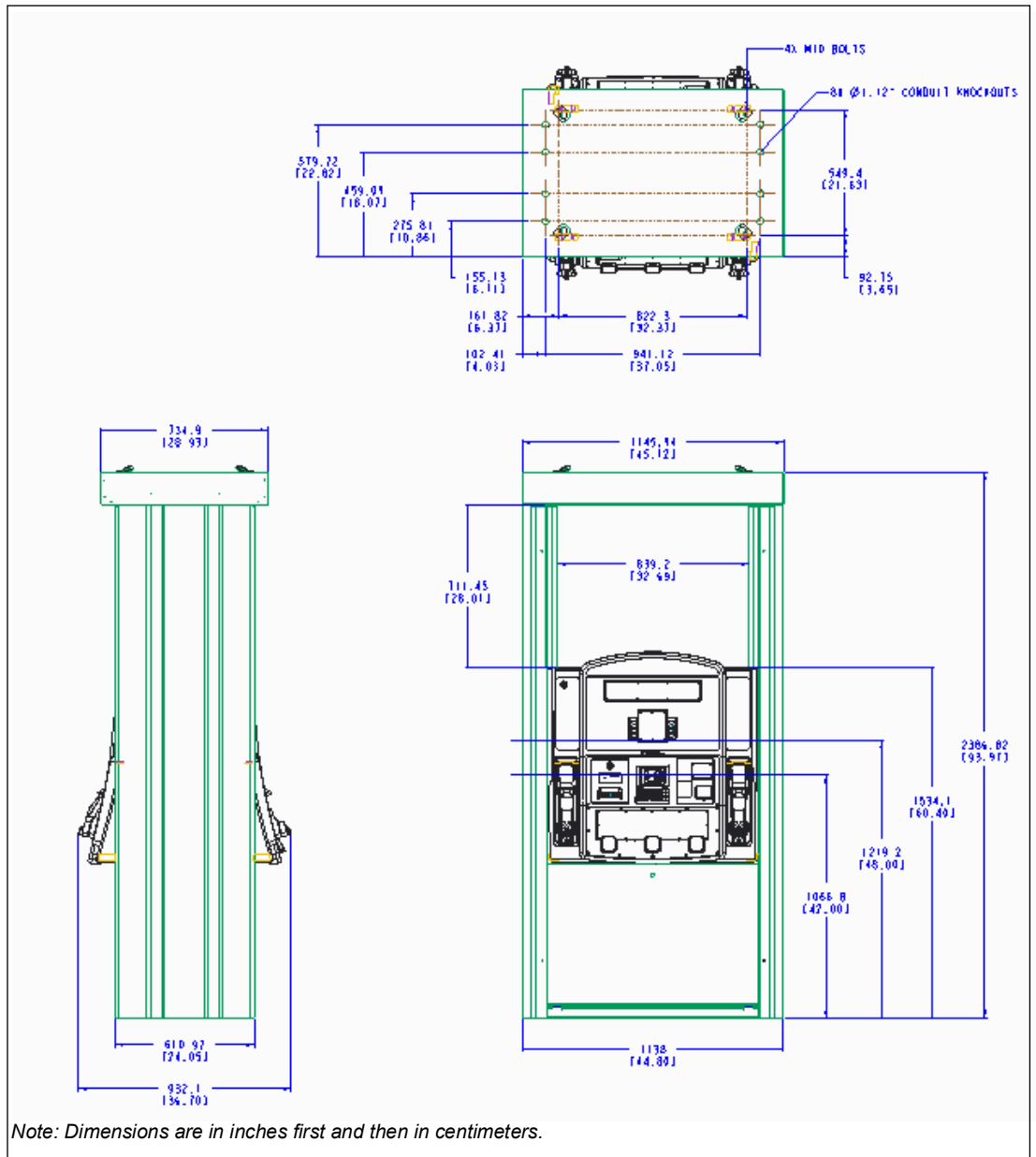

Figure A-25: Encore 900 Elevation Diagram



This page is intentionally left blank.

Index

Numerics

900 9-6, 9-7

A

Alert symbol 2-1
Anchor bolts 4-1
Anchoring
 Pump/Dispenser 6-13
ASC 9-1, 9-7, 9-10

B

Barricading 2-1

C

Calibration 10-3
 Encore 500/500 S Units 9-10
Calibration Procedure 9-10
Capped Elbow 7-4
Caution warnings 2-1
Changing Fuel Types 4-4
 Alternative fuels 4-4
 Flexible Fuel model dispensers 4-5
CIM door 7-7
Conduit Installation 4-11
 Vapor Barrier 7-11
 Within the Unit 7-1
Conduit Locations
 Air Gap Entry 7-8
 Side of Electronics Cabinet 7-9, 7-10
Conduit, electrical 10-5
Configuration
 Pump Blender 5-17

D

Danger warnings 2-1
D-Box 10-7
DEF 1-8
 Important Considerations 3-2

E

E25/E40 and E85 Units 4-3
E85 Units
 Important Requirements 4-3
Ecometers 4-6
Electric, Electrical, Electricity 10-3
Electrical
 Shut-off 2-1
Electrician 10-3
Electronics Cabinet 4-12, 10-3
 Wiring 10-3

Elevation Diagram A-1, A-2, A-3, A-4, A-5, A-6, A-7

Emergency
 Electrical shut-off 2-1
Encore Cabinet 4-9
Encore Frame Assembly 7-3
ENY with Nipple 7-4
Epoxy Sealing 7-30
Ethernet Cable 10-8
Evacuation 2-1
Explosions
 Preventing 2-1
EY 7-4
EY with Nipple 7-4

F

Field wiring 7-19
Fires
 Preventing 2-1
For New and Existing Pumps and Existing Dispensers With Fuel In Lines 9-8
For New Dispensers 9-6

G

Ground 10-5, 10-14
Ground Fault Interrupt 4-11
Grounding 10-14

H

Hazardous Locations 3-1
Hose Retriever 8-3

I

Inlet Pipes 6-5
Installation Checklists 4-7
 Hydraulic Related 9-2
 Mechanical 9-2
Installations in Canada 4-12, 7-2, 10-6
Installing Units
 Flexible fuels 6-5

J

J-Box 10-3
 Installation 7-5

K

Killark 7-4
Killark Fittings 7-4

L

Lifting device 4-1
Lifting Encore Units 6-1

M

Magnetic Nozzle Adapter 8-5
Megger tester 7-17
Model Codes 1-5
Mounting the Unit 4-9, 6-1
 Conduit Potting 4-13
 Pit Box 4-10
 Plumbing Requirements 4-10

N

Nylon slings 4-1

P

Pipe 10-17
Pipe, Plumbing 6-11
Pipe, plumbing 6-11, 6-12, 10-17, 10-18
pipe, plumbing 10-18, 10-19
Piping Layout 10-2
Plumb 10-16
Potting Discs 7-14
prover can 9-12
Pump STP 6-4
Purging 9-6
 Underground Lines 9-7
Purging Air from System and Testing 9-5

S

Safety Brace 6-9
Safety Information
 Alert symbol 2-1
 Barricading 2-1
 Emergency electrical shut-off 2-1
 Evacuation 2-1
 NFPA regulations 2-1
 Preventing explosions and fires 2-1
 Regulations 2-1
 Replacement parts 2-1
 Safety symbols 2-1
 Shut-off 2-1
 Signal words 2-1
 Warning words 2-1
Safety symbols 2-1
Setting PPU 9-11
Shear Valve 10-19
Shut-off 2-1
 Emergency electrical 2-1
Shutoff Operation 9-10

Index

Signal words

Safety 2-1

STP 4-4, 4-7, 6-11

Swivel 8-6

T

Teflon tape 6-8

The Advantage Series 4-1

Installation differences 10-2

TLS Console 7-31

V

Vapor Return Line 6-12

W

Warning words 2-1

Warnings 2-1

Wiring 10-6

Call Interface Power Cable 7-22

Combo Neutral Cable 7-22

Combo Pump Handle Cable 7-22

Field Wiring 7-23

Main AC Cable 7-21

Operating Environment 7-15

Transformer Subassembly 7-21

Ultra-Hi Dispenser 7-20

Valve Interceptor Cable 7-22