

# Hydrostatic Reservoir Sensors for Double-Wall Fiberglass Tanks

## Installation Guide



# Notice

---

Veeder-Root makes no warranty of any kind with regard to this publication, including, but not limited to, the implied warranties of merchantability and fitness for a particular purpose.

**Veeder-Root shall not be liable for errors contained herein or for incidental or consequential damages in connection with the furnishing, performance, or use of this publication.**

Veeder-Root reserves the right to change system options or features, or the information contained in this publication.

This publication contains proprietary information which is protected by copyright. All rights reserved. No part of this publication may be photocopied, reproduced, or translated to another language without the prior written consent of Veeder-Root.

Contact TLS Systems Technical Support for additional troubleshooting information at 800-323-1799.

## **DAMAGE CLAIMS / LOST EQUIPMENT**

Thoroughly examine all components and units as soon as they are received. If any cartons are damaged or missing, write a complete and detailed description of the damage or shortage on the face of the freight bill. The carrier's agent must verify the inspection and sign the description. Refuse only the damaged product, not the entire shipment.

Veeder-Root must be notified of any damages and/or shortages within 30 days of receipt of the shipment, as stated in our Terms and Conditions.

## **VEEDER-ROOT'S PREFERRED CARRIER**

1. Contact Veeder-Root Customer Service at 800-873-3313 with the specific part numbers and quantities that were missing or received damaged.
2. Fax signed Bill of Lading (BOL) to Veeder-Root Customer Service at 800-234-5350.
3. Veeder-Root will file the claim with the carrier and replace the damaged/missing product at no charge to the customer. Customer Service will work with production facility to have the replacement product shipped as soon as possible.

## **CUSTOMER'S PREFERRED CARRIER**

1. It is the customer's responsibility to file a claim with their carrier.
2. Customer may submit a replacement purchase order. Customer is responsible for all charges and freight associated with replacement order. Customer Service will work with production facility to have the replacement product shipped as soon as possible.
3. If "lost" equipment is delivered at a later date and is not needed, Veeder-Root will allow a Return to Stock without a restocking fee.
4. Veeder-Root will NOT be responsible for any compensation when a customer chooses their own carrier.

## **RETURN SHIPPING**

For the parts return procedure, please follow the appropriate instructions in the "General Returned Goods Policy" pages in the "Policies and Literature" section of the Veeder-Root **North American Environmental Products** price list. Veeder-Root will not accept any return product without a Return Goods Authorization (RGA) number clearly printed on the outside of the package.

## Introduction

Contractor Certification Requirements .....	1
Product Marking Information .....	1
Related Documents .....	1
Safety Warnings .....	3
Safety Precautions .....	3
System Description .....	4
Detection Capabilities .....	4
Operating Capabilities .....	4
Sensor Models .....	5
Riser Cap Kit .....	5
Cable Seal Kit .....	6

## Installation

Dual-Point Hydrostatic Sensor Installation .....	7
Single-Point Hydrostatic Sensor Installation .....	9

## Appendix A: CCC Certification

## Figures

Figure 1. Plastic Riser cap kit contents .....	5
Figure 2. Cable seal kit contents .....	6
Figure 3. Dual-Point Sensor Installation .....	7
Figure 4. Sensor Field Wiring Diagram .....	8
Figure 5. Epoxy Sealing Sensor Field Connections .....	8
Figure 6. Single-Point Sensor Installation .....	9

## Tables

Table 1. Sensor Part Numbers .....	5
Table 2. Riser Cap Kit (P/N 330020-435) .....	5
Table 3. Cable Seal Kit (P/N 312020-990) .....	6

# Introduction

This manual contains installation procedures for the installation or replacement of a Dual-Point Hydrostatic Sensor or Single-Point Hydrostatic Sensor for fiberglass tanks

This manual assumes all preliminary site preparation is completed, and that wiring from the monitor to the sensor junction box is in place and meets the requirements set out in the appropriate Console Site Prep manual. If this is a new installation or if site preparation is necessary, you must refer to the applicable Site Prep manual.

## Contractor Certification Requirements

Veeder-Root requires the following minimum training certifications for contractors who will install and program the equipment discussed in this manual:

**Service Technician Certification (Previously known as Level 2/3):** Contractors holding valid Technician Certifications are approved to perform installation checkout, startup, programming and operations training, system tests, troubleshooting and servicing for all Veeder-Root Series Tank Monitoring Systems, including Line Leak Detection. This certification includes TLS-3xx and TLS4xx certification training.

**In-Station Diagnostics (ISD-PMC) Technician Certification:** ISD PMC Contractors holding a valid ISD/PMC Certification are approved to perform (ISD/PMC) installation checkout, startup, programming, and operations training. This training also includes troubleshooting and service techniques for the Veeder-Root In-Station Diagnostics system. A current Veeder-Root Technician Certification is a prerequisite for the ISD/PMC course.

All service personal on site must comply with all recommended safety practices identified by OSHA and your employer.

Review and comply with all the safety warnings in the manuals listed in this document above and any other Federal, State or Local requirements.

**Warranty Registrations** may only be submitted by selected Distributors.

## Product Marking Information

### RELATED DOCUMENTS

#### **Documents Required to Install Equipment**

This intrinsically safe apparatus is only for use as part of a Veeder-Root Automatic Tank Gauging System (ATG Console with probes and sensors). To install intrinsically safe apparatus, use the specific control drawing that appears on the nameplate of the applicable associated apparatus (ATG Console):

Equipment	UL/cUL Control Drawing Document No.
<b>Associated Apparatus</b>	
TLS-450/8600	331940-008
TLS-350, TLS-350R	331940-011
TLS-300	331940-013
TLS4/8601	331940-018



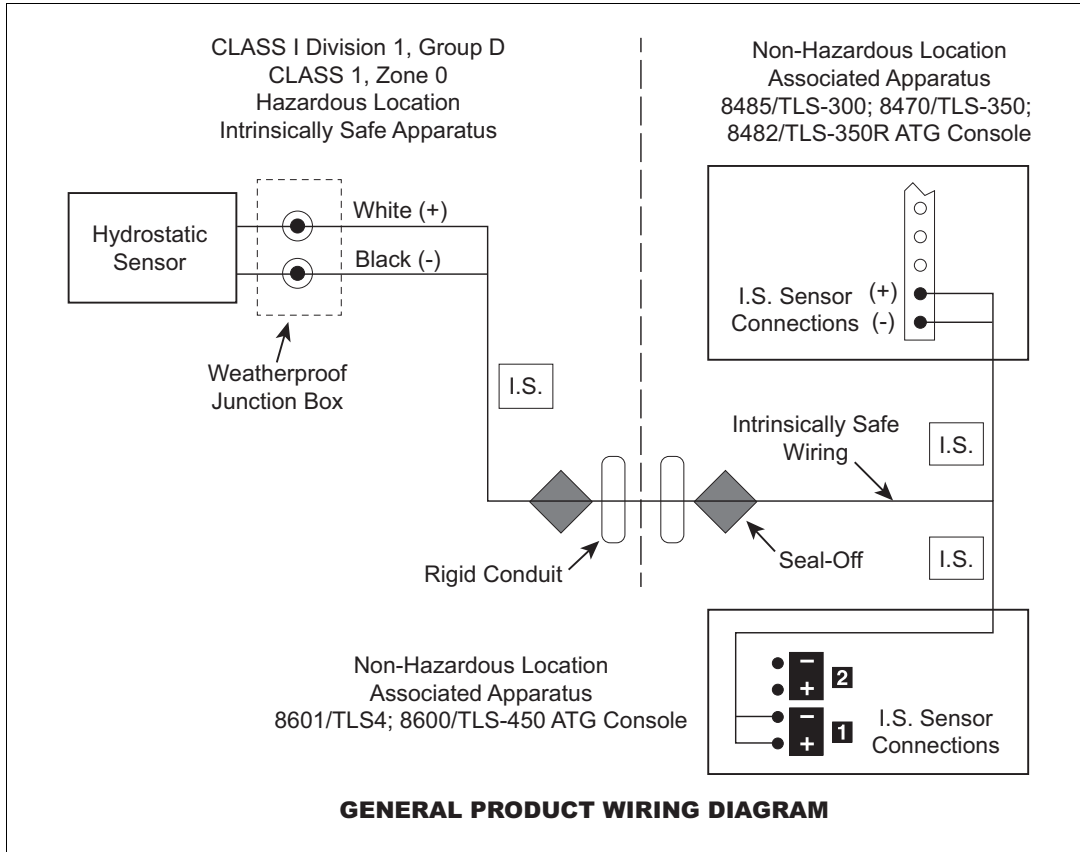



The control drawings contain information related to the correct installation of the overall intrinsically Safe System. This includes information such as maximum number of apparatus, specific apparatus allowed in the system, maximum cable lengths, references to codes, proper grounding and so on. Control drawings can be found on the Internet at <https://www.veeder.com/us/technical-document-library>.



**Product Label Contents**





	I.S. CIRCUIT FOR HAZLOC SENSOR	
		F/N 794380-XXX
CL I, DIV. 1, GP.D		S/N XXXXXX
CL I, ZONE 0	$-40^{\circ}\text{C} \leq T_a \leq +60^{\circ}\text{C}$	
AEx ia IIA		
Ex ia IIA	MANUAL NO. 576013-795	
TC=T4		
SECURITE INTRINSEQUE		





## Safety Warnings

 <b>WARNING</b>	
     	<p>This product is to be installed and operated in the highly combustible environment of a gasoline storage tank where flammable liquids and explosive vapors may be present.</p> <p><b>FAILURE TO COMPLY WITH THE FOLLOWING WARNINGS AND SAFETY PRECAUTIONS COULD CAUSE DAMAGE TO PROPERTY, ENVIRONMENT, RESULTING IN SERIOUS INJURY OR DEATH.</b></p> <ol style="list-style-type: none"> <li>1. Read and follow all instructions in this manual, including all safety warnings to protect yourself and others from serious injury, explosion, or electrical shock.</li> <li>2. Comply with all applicable codes including: the National Electrical Code; federal, state, and local codes; and other applicable safety codes.</li> <li>3. To protect yourself and others from being struck by vehicles, block off your work area during installation or service.</li> <li>4. Do not alter or modify any component or substitute components in this kit.</li> <li>5. Warning! Substitution of components may impair intrinsic safety.</li> <li>6. Field wiring to the Sensor must not share a conduit with any non-intrinsically safe device's wiring.</li> <li>7. Warning! To prevent ignition of flammable or combustible atmospheres, disconnect power before servicing.</li> <li>8. Before installing or taking the unit into a hazardous area, earth the unit in a safe area to remove any static charge. Then immediately transport the unit to the installation site. Do not rub or clean the unit prior to installation. Cleaning is not required under normal service conditions. Do not rub or clean the unit after installation. If the unit is not fixed to a known earth point when installed, ensure that a separate earth connection is made to prevent the potential of a static discharge. When fitting or removing the unit, use of anti-static footwear or clothing is required.</li> <li>9. Materials used in the construction of this device do not contain, by mass, more than 10% in total of aluminum, magnesium, zirconium and titanium or 7.5% in total of magnesium, titanium and zirconium.</li> </ol>

## Safety Precautions

The following safety symbols may be used throughout this manual to alert you to important safety hazards and precautions.

 <p><b>EXPLOSIVE</b> Fuels and their vapors are extremely explosive if ignited.</p>	 <p><b>FLAMMABLE</b> Fuels and their vapors are extremely flammable.</p>
 <p><b>ELECTRICITY</b> High voltage exists in, and is supplied to, the device. A potential shock hazard exists.</p>	 <p><b>TURN POWER OFF</b> Live power to a device creates a potential shock hazard. Turn Off power to the device and associated accessories when servicing the unit.</p>

 <p><b>INJURY</b> Careless or improper handling of materials can result in bodily injury.</p>	 <p><b>WEAR EYE PROTECTION</b> Wear eye protection when working with pressurized fuel lines or epoxy sealant to avoid possible eye injury.</p>
 <p><b>GLOVES</b> Wear gloves to protect hands from irritation or injury.</p>	 <p><b>USE SAFETY BARRICADES</b> Unauthorized people or vehicles in the work area are dangerous. Always use safety cones or barricades, safety tape, and your vehicle to block the work area.</p>
 <p><b>READ ALL RELATED MANUALS</b> Knowledge of all related procedures before you begin work is important. Read and understand all manuals thoroughly. If you do not understand a procedure, ask someone who does.</p>	

## System Description

The Veeder-Root Hydrostatic Reservoir Sensor accurately detects the fluid level change in the reservoir and interstitial space of a double-wall fiberglass tank.

The hydrostatic sensor is available in a Dual-Point or Single-Point configuration. The Dual-Point version is ideal for high groundwater areas, and can differentiate between a high level alarm condition and a low level alarm condition. If an inner-wall leak occurs, the brine solution seeps into the tank lowering the brine level in the reservoir. The Dual-Point Sensor will then trigger a low level alarm. If an outer-wall leak occurs, the groundwater seeps into the reservoir. The Dual-Point sensor will then trigger a high level alarm.

The Single-Point Sensor is ideal for low groundwater areas, since it only detects low level alarm conditions. If an inner-wall leak occurs, the brine solution seeps into the tank. If an outer-wall leak occurs, the brine solution seeps out of the tank. In both cases, the brine level decreases and the Single-Point Sensor triggers a low level alarm.

The housing is constructed of clear PVC, allowing the operator to pull the sensor from the reservoir to visually inspect float operation. A vented riser cap restricts liquid from entering the reservoir.

## DETECTION CAPABILITIES

- Dual-Point sensor alarm conditions:
  - Leak in inner wall triggers a low level alarm.
  - Leak in outer wall triggers a high level alarm in high groundwater areas and a Low level alarm in low groundwater areas.
- Single-Point sensor alarm conditions:
  - Leak in inner or outer wall triggers a low level alarm in low groundwater areas.

## OPERATING CAPABILITIES

- Operating temperature Range: -25°C to +50°C
- Storage Temperature Range: -40°C to +60°C
- Operates in solutions containing 30% calcium chloride or 50% ethylene glycol.
- Cable length: 12 feet
- Single-Point Sensor Dimensions: 6.0" high, 2.5" diameter

- Dual-Point Sensor Dimensions: 17.3" high, 2.5" diameter
- Clear PVC housing permits visual inspection of float operation.

**SENSOR MODELS**

**Table 1. Sensor Part Numbers**

Form No.	Description
794380-301	Single-Point Hydrostatic Sensor
794380-303	Dual-Point Hydrostatic Sensor

**RISER CAP KIT**

The Riser Cap kit contents for both the single- and dual-point hydrostatic sensors are listed in Table 2 and illustrated in Figure 1.

**Table 2. Riser Cap Kit (P/N 330020-435)**

Item	Qty.	Description	P/N
1	1	Plastic 4-inch riser cap	329992-002
2	2	Cord grip nut	330594-001
3	2	Cord grip bushing	330787-002
4	1	Vent tube	329981-001

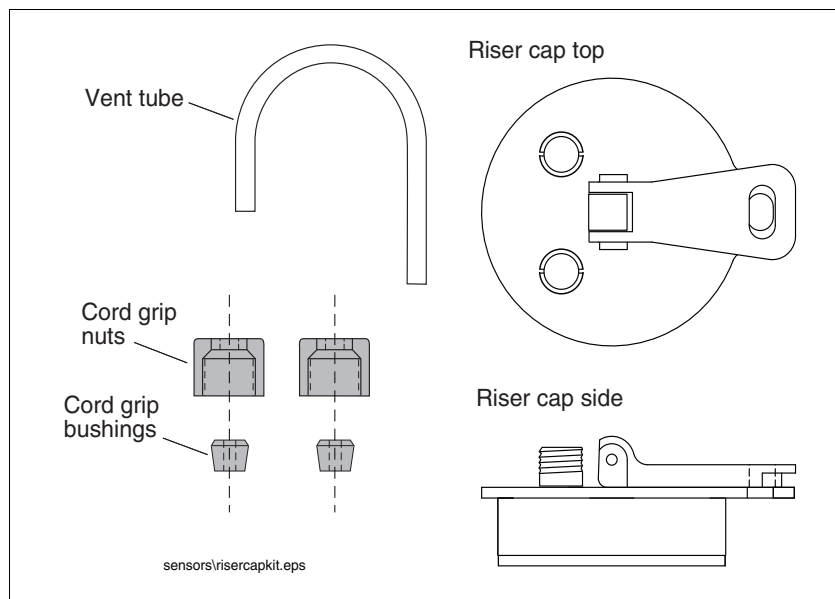

**Figure 1. Plastic Riser cap kit contents**

### CABLE SEAL KIT

The Cable Seal Kit is required for field wiring connections and is listed in Table 3 and illustrated in Figure 2.

**Table 3. Cable Seal Kit (P/N 312020-990)**

Item	Qty.	Description	P/N
1	1	Cord grip assy	331028-011
2	1	Sealing pack	514100-304
3	2	Wire nuts	576008-461
4	2	Tie wrap	510901-337

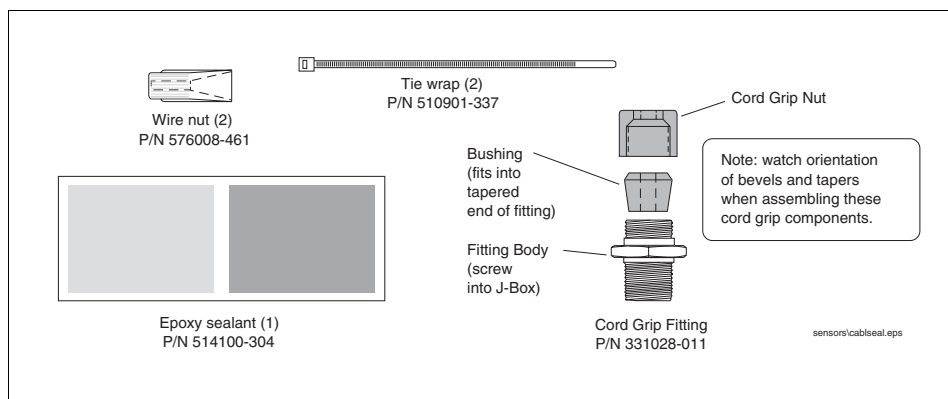

**Figure 2. Cable seal kit contents**

# Installation

## Dual-Point Hydrostatic Sensor Installation



1. Turn Off power to the console.
2. Lower the sensor into the riser until it rests on the bottom of the reservoir (see Figure 3). Note: Refer to the tank manufacturer's instructions for setting the proper brine levels. The ideal brine solution level is approximately halfway between the high and low water levels. With the Dual-Point Sensor resting on the inner-tank wall, the sensor will alarm when the brine level is below 2" or when the brine level is above 13".
3. Install a cord grip bushing/nut into one of the two riser cap fittings. Loosen the nut and push the straight end of the vent tube down through the bushing (ref. Figure 3) about an inch and tighten the cord grip nut. Insert the remaining cord grip bushing and nut from the riser cap kit in the other riser cap fitting. Push the sensor cable up through the loosened second cord grip. Place the cap in the riser and snap down the cap lever to seat the gasket against the inside of the pipe.

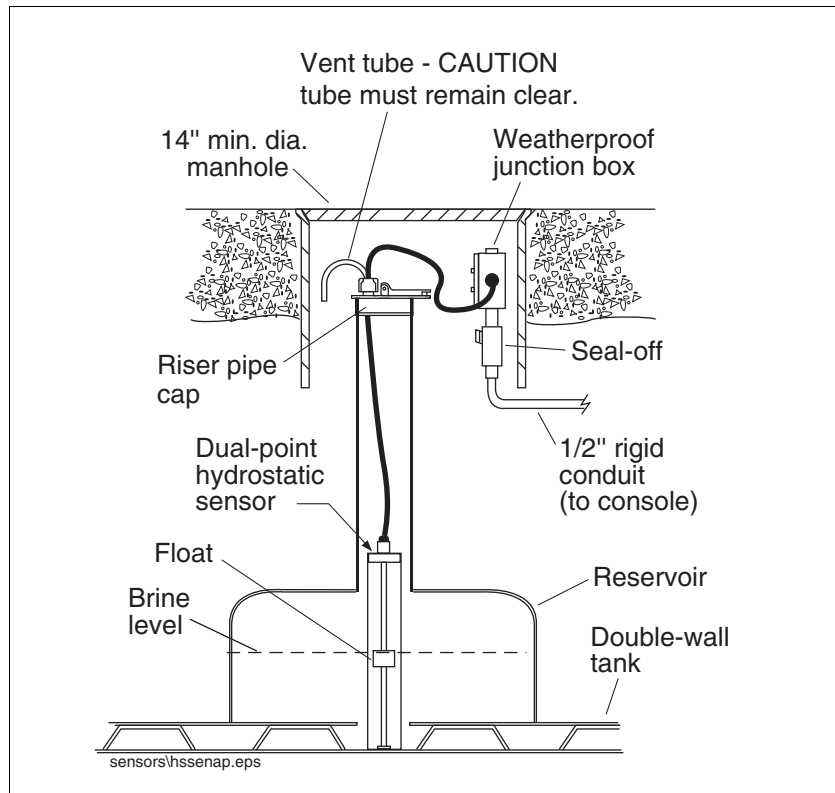

Figure 3. Dual-Point Sensor Installation

4. With the sensor still resting on the bottom of the reservoir, gently pull out the excess sensor cable, leaving a little slack in cable between the cap and the sensor. Tighten the cable's cord grip nut.
5. Install the cord grip from the Cable Seal kit into the field junction box. Push the sensor cable into the junction box through the cord grip. Using the wire nuts from the kit, connect the sensor cable to the console cable as shown in Figure 4. Tighten the cord grip.
6. Seal wire nuts with epoxy sealant following the instructions in Figure 5.
7. Push the epoxy sealed bag into the junction box. Replace and tighten the junction box cover.

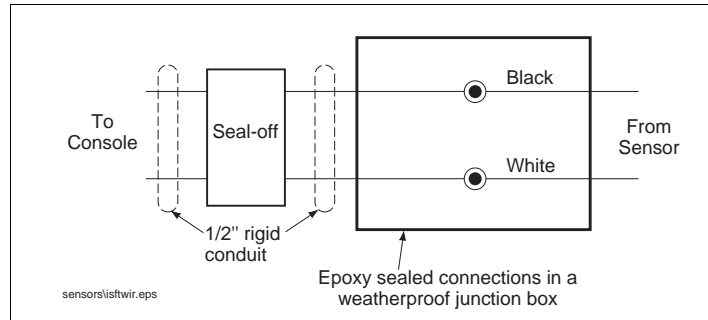

Figure 4. Sensor Field Wiring Diagram

**A**

**B**

**C**

**Instructions:**

NOTE: When temperature is below 50°F (10°C), keep resin in a warm place prior to mixing (e.g., in an inside pocket next to body).

1. Open epoxy sealant package, and remove resin pak.
2. Holding resin pak as shown in A, bend pak along long length.
3. As shown in B, firmly squeeze the RED SIDE of the resin, forcing it through the center seal and into BLACK SIDE.
4. Mix thoroughly to a uniform color by squeezing contents back and forth 25-30 times.
5. Squeeze mixed, warm resin into one end of bag and cutoff other end.
6. Slowly insert wiring connections into sealing pack until they fit snugly against the opposite end as shown in C.
7. Twist open end of bag and use tie wrap to close it off and position the tie wrapped end up until the resin jells.

**CAUTION:** Epoxy sealant is irritating to eyes, respiratory system, and skin. Can cause allergic skin reaction. Contains: epoxy resin and Cycloaliphatic epoxy-carboxylate.

**Precautions:** Wear suitable protective clothing, gloves, eye, and face protection. Use only in well ventilated areas. Wash thoroughly before eating, drinking, or smoking.

consoles\epxy2w.eps

Figure 5. Epoxy Sealing Sensor Field Connections

## Single-Point Hydrostatic Sensor Installation



1. Turn Off power to the console.
2. Install a cord grip bushing/nut into one of the two riser cap fittings. Loosen the nut and push the straight end of the vent tube down through the bushing (ref. Figure 6) about an inch and tighten the cord grip nut. Insert the remaining cord grip bushing and nut from the riser cap kit in the other riser cap fitting. Push the sensor cable up through the loosened second cord grip. Place the cap in the riser and snap down the cap lever to seat the gasket against the inside of the pipe.

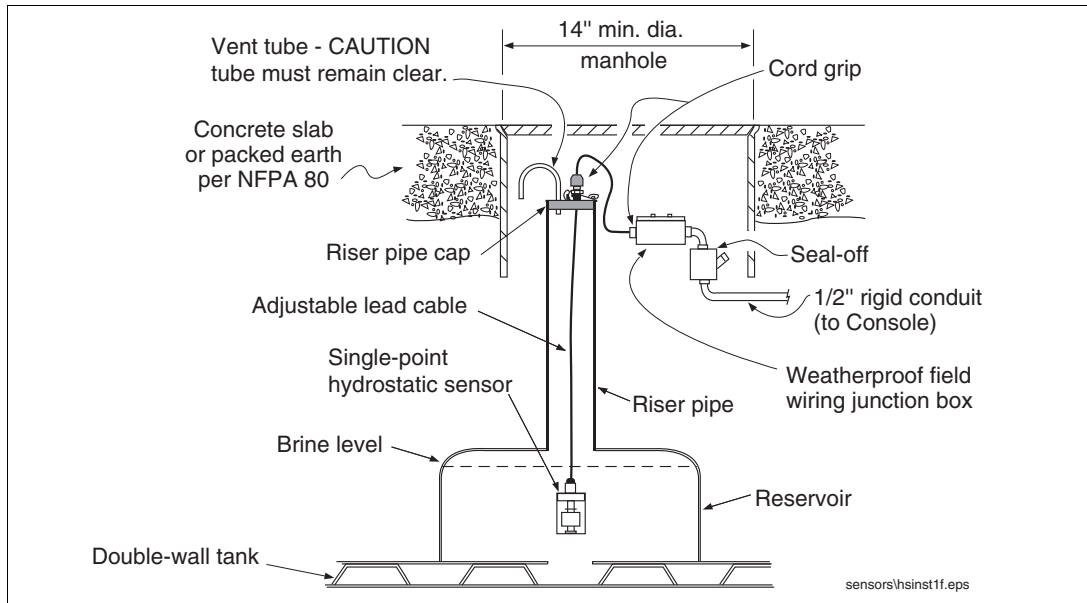

**Figure 6. Single-Point Sensor Installation**

3. Install the cord grip from the Sensor Install Kit into the field junction box. Push the sensor cable into the junction box through the cord grip. Using the wire nuts from the Sensor Install Kit, connect the sensor cable to the console cable as shown in Figure 4. Tighten cord grip.
4. Seal wire nuts with epoxy sealant following the instructions in Figure 5.
5. Turn On power to the console.
6. With the sensor resting on the top of the tank, mark the cable position at the riser cap with a piece of tape.
7. Pull the sensor up until it triggers an alarm on the console. Mark the cable position at the top of the cap with a piece of tape.
8. Lower the sensor until the riser cap is halfway between the taped marks on the cable.
9. Secure the sensor in position by tightening the cable cord grip in the cap (see Figure 6).

## Appendix A: CCC Certification

本产品经认证符合 CNCA-C23-01: 2019《强制性产品认证实施规则 防爆电气》的要求。

*The product(s) is verified and certified according to CNCA-C23-01: 2019 China Compulsory Certification Implementation Rule on Explosion Protected Electrical Product.*



#	产品名称 Product 型号 Type	防爆标志 <i>Ex Marking</i>	3C 证书编号 CCC Certificate No.
1	静压水传感器 7943XX-30X	Ex ia IIA T4 Ga	2021312315000434

