

ProLink

Sonic Network Card Installation Manual

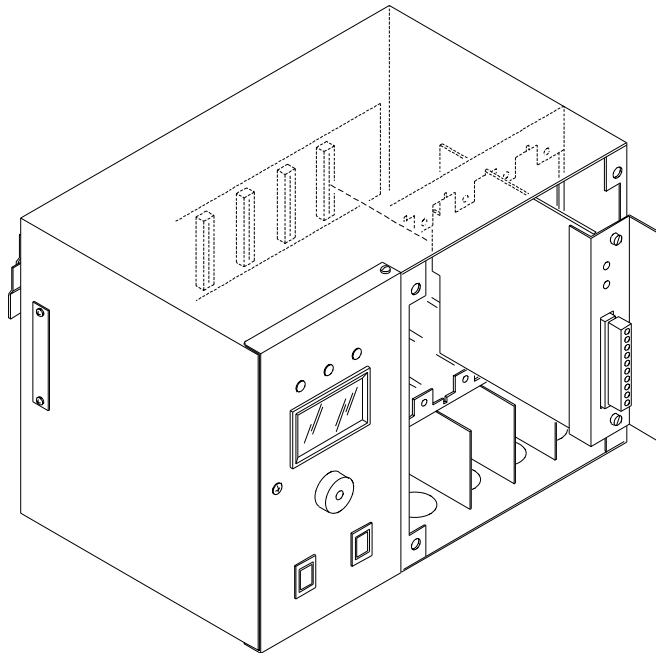

ProLink Fuel Management System

RE260-277
Rev C
July '00

Sonic Network Card Installation Manual

RE260-277 • Rev C • July '00

Certifications and Listings

Marley Pump Company is ISO 9001 certified.

The Prolink has been approved by Underwriters Laboratories to carry the UL Listing Mark.

The Prolink has been approved by Underwriters Laboratories of Canada to carry the ULC Listing Mark.

Trademarks

The logos for Red Jacket and Marley Pump are property of The Marley Pump Company. Extracta and Trapper are trademarks of The Marley Pump Company. The UL logo is property of Underwriters Laboratories Inc. Other trademarks that appear in this manual include Belden, Echelon, LonWorks, Teflon, and Viton.



© 2000, Marley Pump, a United Dominion company. The Marley Pump Company reserves the right to make design improvements and pricing modifications as necessary and without notice. Marley Pump is not responsible for the operation of equipment from other manufacturers when used in conjunction with Red Jacket petroleum equipment. The information in this manual is proprietary and intended only for distributors, installers, and owners of Red Jacket equipment. Any other use of this manual in part or in whole must be authorized in writing by:

The Marley Pump Company
500 East 59th St
Davenport, IA 52807
319.391.8600

TABLE OF CONTENTS

About This Manual	vii
ORGANIZATION	VII
TYPOGRAPHICAL CONVENTIONS	VII
TERMINOLOGY	VIII
Chapter 1: Before You Start	1-1
INTRINSIC SAFETY INFORMATION	1-1
INSTALLATION DOs AND DON'Ts	1-2
Chapter 2: Introduction to the Sonic Network Card	2-1
INTRODUCTION AND OVERVIEW.....	2-1
INSTALLATION REQUIREMENTS.....	2-1
SONIC NETWORK CARD CONFIGURATION WORKSHEET INFORMATION.....	2-2
Chapter 3: Conduit and Direct Bury Cable Installation	3-1
CONDUIT INSTALLATION.....	3-1
DIRECT BURY CABLE INSTALLATION.....	3-3
Chapter 4: Ultrasonic Probe Installation	4-1
METHODS OF ULTRASONIC PROBE INSTALLATION	4-1
ULTRASONIC PROBE CONFIGURATION WORKSHEET INFORMATION.....	4-2
INSTALLING AN ULTRASONIC PROBE IN A DEDICATED RISER.....	4-3
SIZING INSTRUCTIONS FOR ULTRASONIC PROBES USING A STRAIGHT HANGER.....	4-3
PREPARING THE ULTRASONIC PROBE TO INSTALL IN A DEDICATED RISER	4-5
INSTALLING THE FEEDTHROUGH ASSEMBLY IN AN EXISTING RISER CAP	4-10
CONNECTING THE ULTRASONIC PROBE TO THE INTERCONNECT CABLE	4-11
INSTALLING AN ULTRASONIC PROBE IN A DELIVERY RISER	4-12
INSTALLATION CONSIDERATIONS	4-13
TANK PREPARATIONS AND MODIFICATIONS	4-13

SIZING INSTRUCTIONS FOR ULTRASONIC PROBES USING AN OFFSET HANGER	4-15
SIZING THE OFFSET HANGER	4-17
PREPARING THE ULTRASONIC PROBE FOR INSTALLATION IN DELIVERY RISER	4-20
INSTALLATION OF ULTRASONIC PROBE	4-22
ULTRASONIC PROBE DEPLOYMENT	4-26
MODIFICATION AND INSTALLATION OF THE DROP TUBE	4-27
Chapter 5: Installation of the Sonic Network Card	5-1
INSTALLING THE SONIC NETWORK CARD IN THE PROLINK CHASSIS.....	5-1
CONNECTING THE ULTRASONIC PROBE TO THE SONIC NETWORK CARD	5-3
CABLE CONNECTIONS AT THE SONIC NETWORK CARD.....	5-3
Chapter 6: Pathway Plus Setup.....	6-1
Appendix A: Replacement Parts	A-1
Index	I-1

LIST OF FIGURES

Figure 2.1	Sonic network card and Ultrasonic probe required information.....	2-2
Figure 3.1	Installation Diagram for Conduit.....	3-2
Figure 3.2	Installation Diagram for Direct Bury or Sawcut.....	3-3
Figure 3.3	Diagram for Direct Bury Cable Installation	3-4
Figure 4.1	Ultrasonic probe required information	4-2
Figure 4.2	Calculating Tank Diameter	4-4
Figure 4.3	Water Float Installation for Use in a Dedicated Riser.....	4-5
Figure 4.4	Diesel Clip Attachment for Use in Dedicated riser	4-6
Figure 4.5	Measurement for Straight Hanger Installation.....	4-6
Figure 4.6	Attaching the Chain to Lower Riser Bracket.....	4-7
Figure 4.7	A & B Lowering the Sensor into Tank & Securing the Straight Hanger into Position .	4-8
Figure 4.8	A, B, and C: Compression Fitting Used for Existing Riser Cap.....	4-9
Figure 4.9	A & B Removing and Installing Feedthrough Assembly in Existing Riser Cap	4-10
Figure 4.10	Connector Board and Housing.....	4-11
Figure 4.11	Top View of Tank	4-13
Figure 4.12	Modifications to the Riser	4-14
Figure 4.13	Removal and Installation of Feedthrough Assembly.....	4-15
Figure 4.14	Measurements for Mounting Ultrasonic probe in Tank.....	4-16
Figure 4.15	Relocation of Hanger Crossarm	4-17
Figure 4.16	Installation Tool Connection to Offset Hanger.....	4-18
Figure 4.17	Lowering the Offset Hanger into Tank.....	4-18
Figure 4.18	Deploying Offset Hanger	4-19
Figure 4.19	Offset Hanger Removal.....	4-20
Figure 4.20	Water Float Installation for Use in a Delivery Riser.....	4-21
Figure 4.21	Diesel Clip Attachment for Use in Delivery Riser	4-21
Figure 4.22	Removing the Cable/Chain Retainer.....	4-22
Figure 4.23	Measuring for Offset Hanger Installation.....	4-23
Figure 4.24	Attaching the Cable and Chain to the End Plate.....	4-24
Figure 4.25	Ultrasonic probe Cable Routing with Offset Hanger.....	4-25
Figure 4.26	Attaching the sensor installation tool.....	4-25
Figure 4.27	Inserting Hanger with Sensor and Routing into Riser	4-27

Figure 4.28	Sizing Drop Tube	4-28
Figure 4.29	Aligning and installing the Drop Tube	4-29
Figure 5.1	Installing the Sonic network card	5-2
Figure 5.2	Connections at the Sonic network card.....	5-3

About This Manual

This preface describes the organization of this manual, explains the symbols and typographical conventions used, and defines vital terminology.

Organization

This manual is organized into six chapters:

Chapter 1: Before You Start

Chapter 2: Introduction to the Sonic Network Card

Chapter 3: Conduit and Direct Bury Cable Installation

Chapter 4: Ultrasonic Probe Installation

Chapter 5: Installation of the Sonic Network Card

Chapter 6: Pathway Plus Setup

It also contains an appendix and an index.

Typographical Conventions

The various symbols and typographical conventions used in this manual are described here.

Numeric Formats	A numeric zero looks like 0 in this document. An uppercase letter “oh” is rendered as O. A numeric one looks like 1 in this document. A lowercase letter “ell” is rendered as l. However, to prevent confusion, the abbreviation for milliliter includes a capital letter (mL).
------------------------	--

Terminology

The following terms are used throughout this manual to bring attention to the presence of hazards of various risk levels, or to important information concerning use of the product.

DANGER!!

Indicates the presence of a hazard that ***will*** cause ***severe*** personal injury, death, or substantial property damage ***if ignored***.

WARNING!

Indicates the presence of a hazard that ***can*** cause ***severe*** personal injury, death, or substantial property damage ***if ignored***.

Caution

Indicates the presence of a hazard that ***will*** or ***can*** cause ***minor*** personal injury or property damage ***if ignored***.

Notice

Indicates special instructions on installation, operation, or maintenance that are important, but not related to personal injury hazards.

Chapter 1: Before You Start

This Chapter Explains:

- Intrinsic Safety
- Installation DOs and DONTs

Intrinsic Safety Information

ATTENTION INSTALLER

READ THIS IMPORTANT SAFETY INFORMATION BEFORE BEGINNING WORK

Portions of this product will be installed and operated in the highly combustible environment of a petroleum product storage tank. It is essential that you carefully read and follow the warnings and instructions in this manual to protect yourself and others from serious injury, explosion, electrical shock, or death.

WARNING!	<p>All installation and programming of the Red Jacket Prolink chassis should be performed by factory trained personnel only. Before beginning any installation procedure, carefully read and understand all instructions.</p> <p>Failure to follow these guidelines can result in severe personal injury, death, or substantial property damage. Retain a copy of this manual on site with the Prolink system as required by EPA regulations in paragraph 40CFR 280.45. Installations must comply with section 504, article 300 of the N.E.C. which defines intrinsic safety.</p>
-----------------	---

*Precautions must be taken in the installation of this product to limit power in the wiring to the fuel tanks and to keep that wiring physically separated from any other wiring (**intrinsically safe**).*

Notice

It is your responsibility to maintain the effectiveness of the safety features by installing this product in accordance with the instructions and warnings that follow. Failure to do so could create danger to life and property and will result in voiding all warranties connected with this product.

Installation DOs and DON'Ts

WARNING!

Failure to follow these guidelines could result in severe personal injury, death, or substantial property damage.

DOs

The following list represents the **DOs** for installing the Sonic network card. Please read through this list before beginning the installation.

- **DO** plan all conduit or direct-bury runs and contractor's box installations before mounting a Pro-link chassis.
- **DO** install the system to meet the National Electric Code(section 504, article 300); federal, state, and local codes; and any applicable safety regulations.
- **DO** disconnect all power before making final connections.
- **DO** maintain intrinsic safety. Sensor wires must be separated from all other non-intrinsically safe wiring. Install the safety tag on all intrinsically safe contractor's boxes.
- **DO** use Red Jacket required interconnect cable for conduit or direct bury applications.
- **DO** observe proper conduit access into the Prolink chassis.
- **DO** mount the Prolink chassis in a dry, climate controlled environment.
- **DO** hardwire the Prolink chassis to a dedicated, isolated circuit breaker.
- **DO** store a copy of the Prolink Installation and Configuration Worksheet on site (After programming is complete).
- **DO** install a station ground rod (if one is not present) and verify that it is connected to the Pro-link main data chassis.
- **DO** use Red Jacket supplied connector boards and housings for all field connections to the Ultrasonic Probe.
- **DO** install and startup the Ultrasonic Network card with a minimum of three rings submerged in the product (28") for each Ultrasonic Probe.

WARNING!

Failure to verify this ground connection **CAN** cause **SEVERE** personal injury, death, or substantial property damage.

WARNING!

Failure to comply with these installation requirements will void product warranty.

DON'Ts

The following list represents the DON'Ts for installing the Sonic network card. Please read through this list before beginning the installation.

- **DON'T** short circuit the power supply.
- **DON'T** handle the Sonic network card or other circuit boards without proper grounding straps.
- **DON'T** allow unauthorized field service personnel to work on the internal circuits of the Prolink chassis or the Sonic network card. Unauthorized work will adversely affect the intrinsic safety of the system and void product warranty.
- **DON'T** run any other lines or power devices through a Prolink chassis. The Prolink chassis is a low-voltage device.
- **DON'T** drill any holes in a Prolink chassis.
- **DON'T** hammer the cable into the sawcut.
- **DON'T** pull ultrasonic probe wires more than 1,000 feet maximum from the Prolink chassis.
- **DON'T** use cold water pipe as earth ground.
- **DON'T** cross barriers of low voltage with high voltage wire.
- **DON'T** use any cable other than Red Jacket supplied and authorized conduit or direct bury cable between the Ultrasonic Network card and the Ultrasonic Probe (refer to Appendix A).
- **DON'T** make field connections to the Ultrasonic Inventory Probe without the use of Red Jacket supplied connector boards and housings.
- **DON'T** forget to install the connector board housing end caps with the use of a gas and oil resistant thread sealant with the compression fittings finger tightened around the cable.
- **DON'T** fail to use the desiccant packs and strain relief wire ties in the connector board housings per the instructions.
- **DON'T** forget to calibrate the level, water and product temperature.

Chapter 2: Introduction to the Sonic Network Card

This Chapter Explains:

- **Introduction and Overview**
- **Installation Requirements**
 - Sonic Network Card Configuration Worksheet Information

Introduction and Overview

The Sonic network card is the interface between the Prolink network and four Ultrasonic probes. The Ultrasonic probe uses a transceiver to determine inventory levels. The Sonic network card is a four channel card, meaning that it is capable of monitoring up to four ultrasonic probes.

Notice	Manifolded or siphoned tanks must be wired up to the same Sonic Network card.
---------------	---

Installation Requirements

The Sonic network card requires an open slot in a Prolink chassis. Ultrasonic probe cable connections are made at the connector on the front faceplate of the card.

Sonic Network Card configuration worksheet information

When installing the Sonic network card, certain information must be recorded.

- Card serial number
- Card date of manufacture
- Card neuron ID number
- Part Number
- Card chassis number
- Card slot number

This information should be entered on the Prolink Programming Configuration Worksheet. (WAF03) Refer to *figure 2.1*.

Prolink Configuration Worksheet– SAMPLE

Chassis # _____		Slot 1	
Type of Network Card Installed	Network Card Type	Sonic NETWORK CARD	
	Neuron ID Number	12/15/98 123456789 REXXX-XXX	<p>Date Code</p> <p>Sensor Type and Location</p>
CHANNEL 1 PROBE/SENSOR TYPE		Sonic PROBE TANK 2 12/15/98 123456789 ABCD12345 REXXX-XXX	Serial Number
CHANNEL 2 PROBE/SENSOR TYPE		Sonic PROBE TANK 4 12/15/98 123456789 ABCD12345 REXXX-XXX	
CHANNEL 3 PROBE/SENSOR TYPE		Sonic PROBE TANK 3 12/15/98 123456789 ABCD12345 REXXX-XXX	
CHANNEL 4 PROBE/SENSOR TYPE		MAG PROBE TANK 1 12/15/98 123456789 ABCD12345 REXXX-XXX	

Figure 2.1 Sonic network card and Ultrasonic probe required information

Chapter 3: Conduit and Direct Bury Cable Installation

This Chapter Explains

- Conduit Installation
- Direct Bury Cable Installation

Conduit Installation

When installing the Ultrasonic probe cable in conduit, See Figure 3.1. Note: The maximum probe distance from the Prolink enclosure is 1,000 ft(300m).

Notice	Conduit from the Ultrasonic probe to the Sonic network card must not contain any non-intrinsically safe wires. Only Red Jacket supplied cable is authorized for use between the Ultrasonic Network card and the Inventory Sensor (refer to Appendix A).
---------------	---

Step 1: Run the proper interconnect cable from the Ultrasonic probe to the Prolink chassis. Do Not drill any holes in the Prolink chassis. Use the appropriate knockouts to access the enclosure. Follow all local, state, and federal codes.

Step 2: Allow for a 3-ft. to 4-ft. service loop on the ultrasonic probe side of the cable. Refer to the section *Connections at the Junction box, Conduit Installations* in Chapter 4 for detailed instructions on connecting the Ultrasonic probe to the interconnect cable.

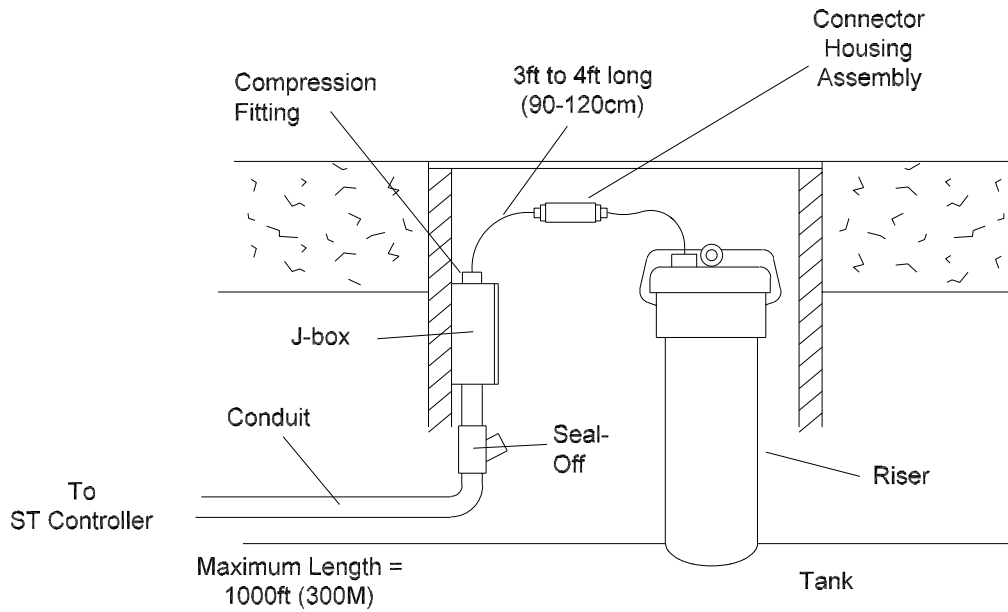

Figure 3.1 Installation Diagram for Conduit

If you have questions about your specific application, call Red Jacket Technical Support 1-800-777-2480.

Direct Bury Cable Installation

Notice	Only Red Jacket supplied cable is authorized for use between the Ultrasonic Network card and the Inventory Sensor (refer to Appendix A).
---------------	--

The dimensions of the sawcut are approximately ¼-in. x 2 to 3-in. The depth of the sawcut is determined by the number of cables being inserted into the sawcut, (one cable per probe is required).

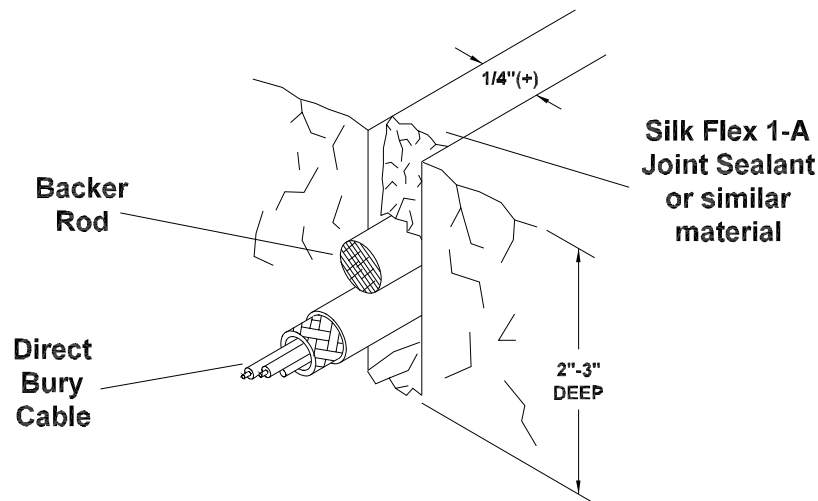

Figure 3.2 Installation Diagram for Direct Bury or Sawcut

Use normal industry standards when cutting the pavement slit or trenching. Teflon cable may be required in order to comply with local codes (refer to Appendix A). All steps taken to prevent damage to the conductors will help maintain the electrical characteristics of the cable. Sawcut all corners at a 45° angle. The cable is not designed to make a 90° bend. Exercise caution when inserting the cable into the sawcut. Do not use sharp objects, such as screwdrivers. A backer rod may be used to help fill the sawcut after the cable has been inserted.

The cable must be **concealed in rigid conduit** from the end of the sawcut **until it enters the Prolink chassis**. Follow all local, state, and federal codes when performing direct bury installations. Allow for a 3-ft. to 4-ft. long service loop on the inventory probe side of the cable. Maximum distance is 1,000 ft(300m) from the Prolink enclosure.

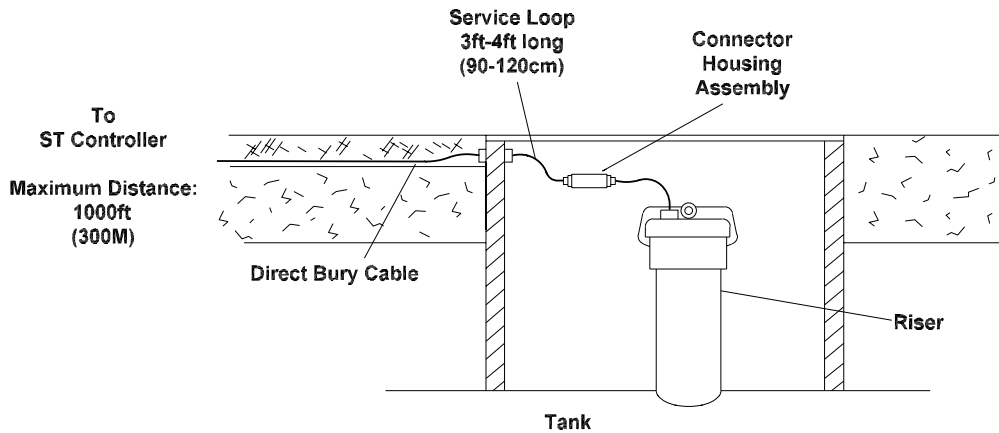

Figure 3.3 Diagram for Direct Bury Cable Installation

Refer to the section *Connections at the Junction box, Conduit Installations* in **Chapter 4** for detailed instructions on connecting the Ultrasonic probe to the interconnect cable.

If you have questions about your specific application, call Red Jacket Technical Support 1-800-777-2480.

Chapter 4: Ultrasonic Probe Installation

This Chapter Explains

- **Methods of Ultrasonic Probe installation**
- Ultrasonic Probe configuration worksheet information
- **Installing an Ultrasonic Probe in a dedicated riser**
- **Installing an Ultrasonic Probe in a delivery riser**

Methods of Ultrasonic Probe installation

The Ultrasonic probe may be installed in either a dedicated riser or in a delivery riser. In a dedicated riser, a straight hanger is used to suspend the probe directly below the riser opening. In a delivery riser, an offset hanger is used to suspend the probe 16 inches away from the delivery riser and drop tube.

Ultrasonic probe configuration worksheet Information

When installing and connecting the Ultrasonic probe, certain information must be recorded for system programming. This information is:

- **Serial number of sensor**
- **Date of manufacture**
- **Location and ID of sensor**
- **Part Number**
- **Information on the Sonic network card that this sensor is connected to:**
 - Channel number on the Sonic network card
 - Chassis number for the Sonic network card
 - Slot number for the Sonic network card

This information should be entered on the Prolink Programming Configuration Worksheet. (WAF03) Refer to *figure 4.1*.

Prolink Configuration Worksheet– SAMPLE

Chassis # _____		Slot 1	
Type of Network Card Installed		SONIC NETWORK CARD	
		12/15/98	
		123456789	
		REXXX-XXX	
			Probe Type and Location
CHANNEL 1 PROBE/SENSOR TYPE		SONIC PROBE TANK 2	
		12/15/98	Date Code
		123456789	Serial Number
		REXXX-XXX	
			Water Float Installed–Yes or No
CHANNEL 2 PROBE/SENSOR TYPE		SONIC PROBE TANK 4	
		12/15/98	
		123456789	
		REXXX-XXX	
			Part Number
CHANNEL 3 PROBE/SENSOR TYPE		SONIC PROBE TANK 3	
		12/15/98	
		123456789	
		REXXX-XXX	

Figure 4.1 Ultrasonic probe required information

Installing an Ultrasonic Probe in a Dedicated Riser

- Sizing Instructions for Ultrasonic probes using a straight hanger
- Preparing the Ultrasonic probe to install in a dedicated riser
- Installing feedthrough assembly in existing riser cap
- Ultrasonic probe wiring connections
- Wiring the Ultrasonic probe to interconnect cable

Sizing Instructions for Ultrasonic Probes Using a Straight Hanger

Step 1: Use an undamaged tank stick to measure the distance from the bottom of the tank to the top of the riser, measurement **(A)**. This is shown in *figure 4.2*.

Notice	It is normal for tank sticks to become worn when used daily. Inspect tank stick for wear and complete length before using.
---------------	--

Step 2: Use a rigid measuring tape to measure the length of the riser from the bottom inside edge to the top of the pipe. This is measurement **(B)**. Refer to *Figure 4.2*.

Notice	The riser length required for this installation is a minimum of 14-in(35cm) and a maximum of 48-in(120cm) If the riser is longer than 48-in(120cm), contact Red Jacket Customer Service for a special chain length.
---------------	---

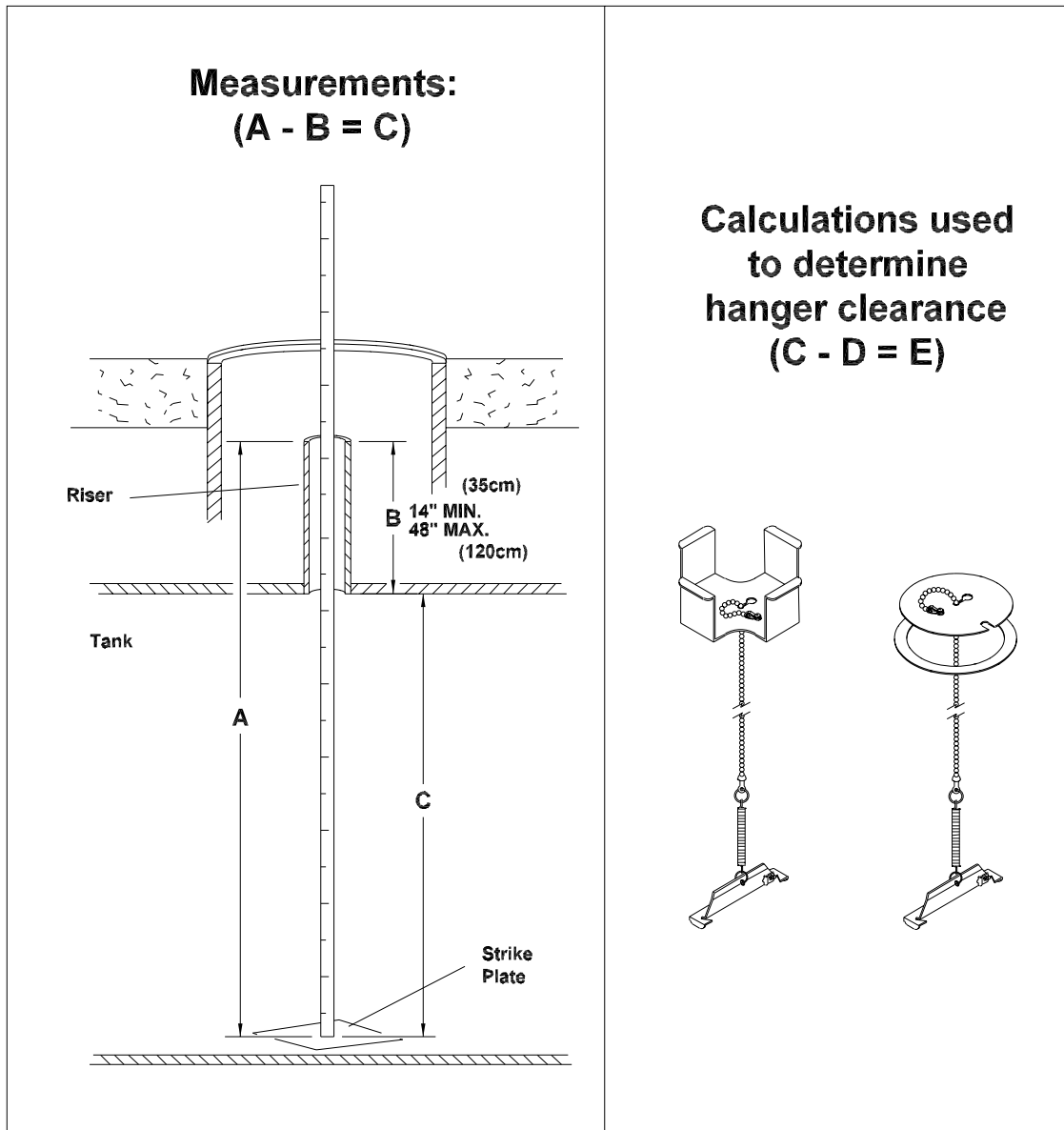

Figure 4.2 Calculating Tank Diameter

- Step 3:** Subtract measurement (**B**) from measurement (**A**) to calculate the actual inside diameter of the tank, measurement (**C**). Refer to *figure 4.2*.
- Step 4:** If using the straight hanger, subtract 3-in.(7.6cm) from (**C**), (**C - 3"=D**). If using the offset hanger, refer the section titled Installation of Ultrasonic probe in Delivery Riser later in this chapter.
- Step 5:** Round calculation (**D**) *down* to the nearest available probe length and refer to the section named Part Numbers for Ultrasonic probes in Appendix A: Parts List of this manual.

Preparing the Ultrasonic Probe to Install in a Dedicated Riser

Step 1: Lay the Ultrasonic probe on the ground and install the water float. Refer to *figure 4.3*.

Caution

Improper alignment of the water float assembly will cause incorrect readings. The water float guide should be aligned parallel with the vertical rods of the sensor. This can be accomplished by *eyeing* the alignment and bending by hand. If the water float tilts inward too much (0.5-in. or 13-mm) the ultrasonic reflection from the water float bracket will degrade sensor performance.

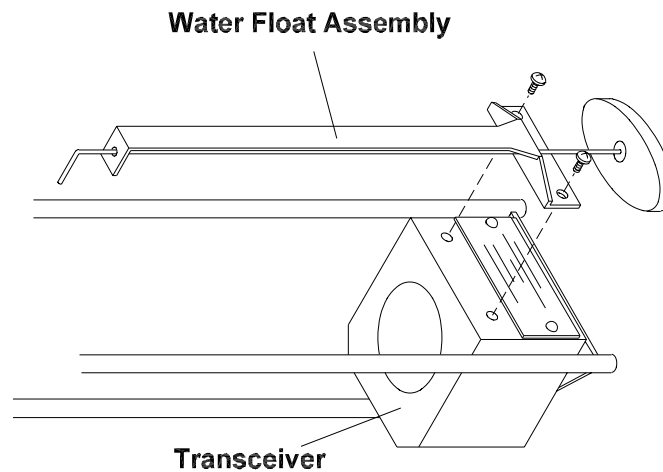

Figure 4.3 Water Float Installation for Use in a Dedicated Riser

Notice

For applications involving kerosene or diesel, install the diesel clip onto the water float. If clip is required refer to figure 4.4

Specific Gravity of Product	Number of Clips
Gasoline - 0.69 to 0.78	0
Kerosene/Diesel - 0.78 to 0.87	1

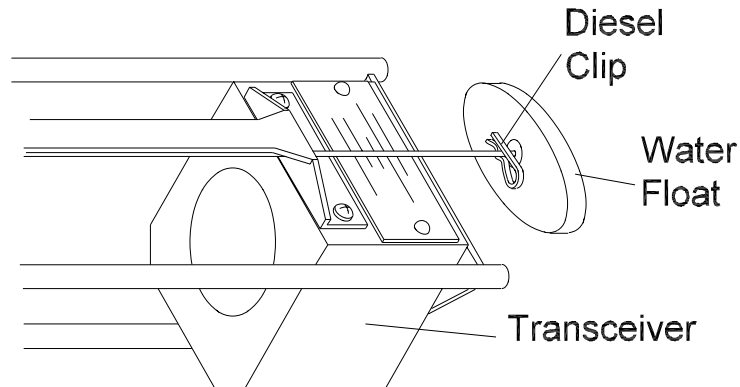

Figure 4.4 Diesel Clip Attachment for Use in Dedicated riser

Step 2: To get the correct overall length, lay the tank stick on the ground next to the sensor. Place the bottom of the transceiver block at the 2-in(5cm) mark on the tank stick, as shown in *figure 4.5*. Attach the chain to the lower riser bracket (*figure 4.5*) so that the bracket is at the calculated inside tank diameter (*measurement C*) in *figure 4.5*.

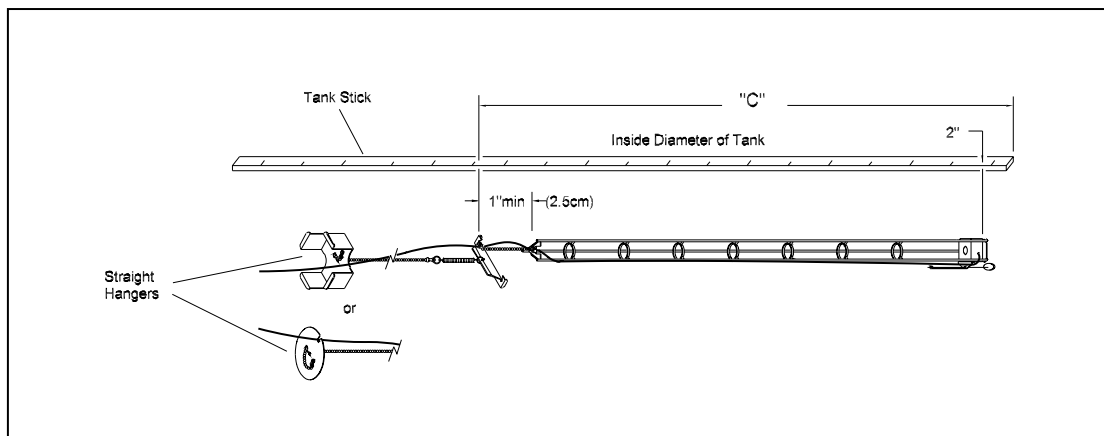

Figure 4.5 Measurement for Straight Hanger Installation

Notice

Do Not over-tighten the cable or chain retainer. The cable should be able to slide easily. Do Not attach the sensor closer than 1-in(2.5cm) from the lower riser bracket.

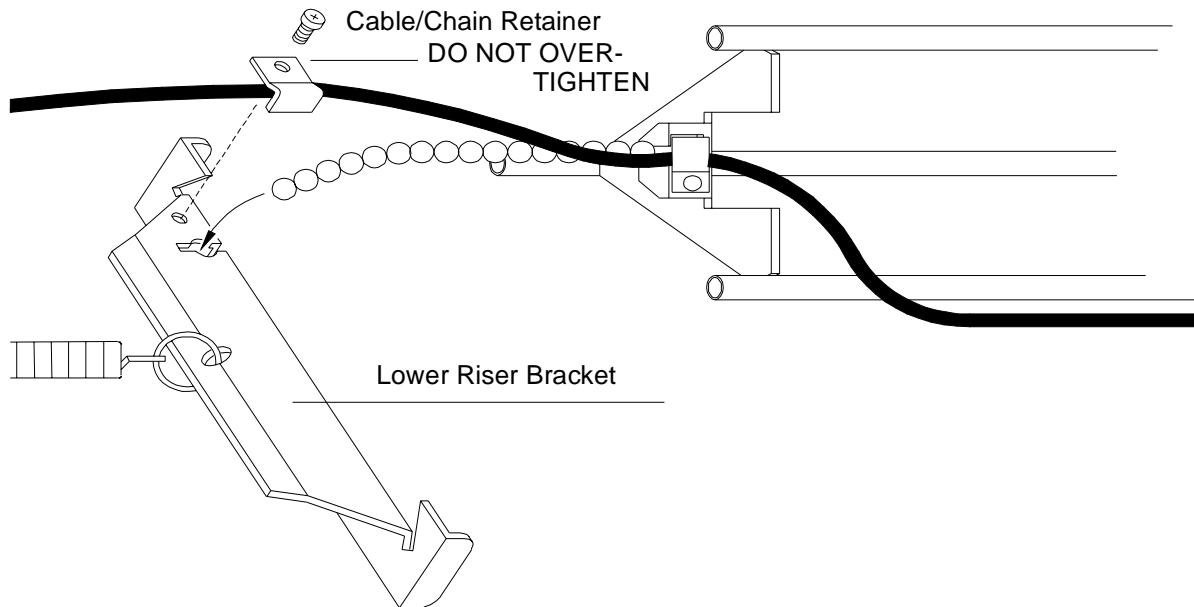

Figure 4.6 Attaching the Chain to Lower Riser Bracket

Notice

Be careful not to bend or break the water float when lowering it into the riser. A damaged water float will not correctly register the water level.

- Step 3:** Lower the probe into the riser using the hanger's chain, until it touches the bottom of the tank. *Do not use the interconnect cable as a means of lowering the sensor into the tank.* An example of this is shown in *figure 4.7A*.
- Step 4:** Pull up on the chain to catch the lower riser bracket on the bottom of the riser pipe (see *figure 4.7B*).
- Step 5:** While holding the chain taut, slide the upper riser bracket down the chain until it is seated in the riser opening. Refer to *figure 4.7A* while performing this task.

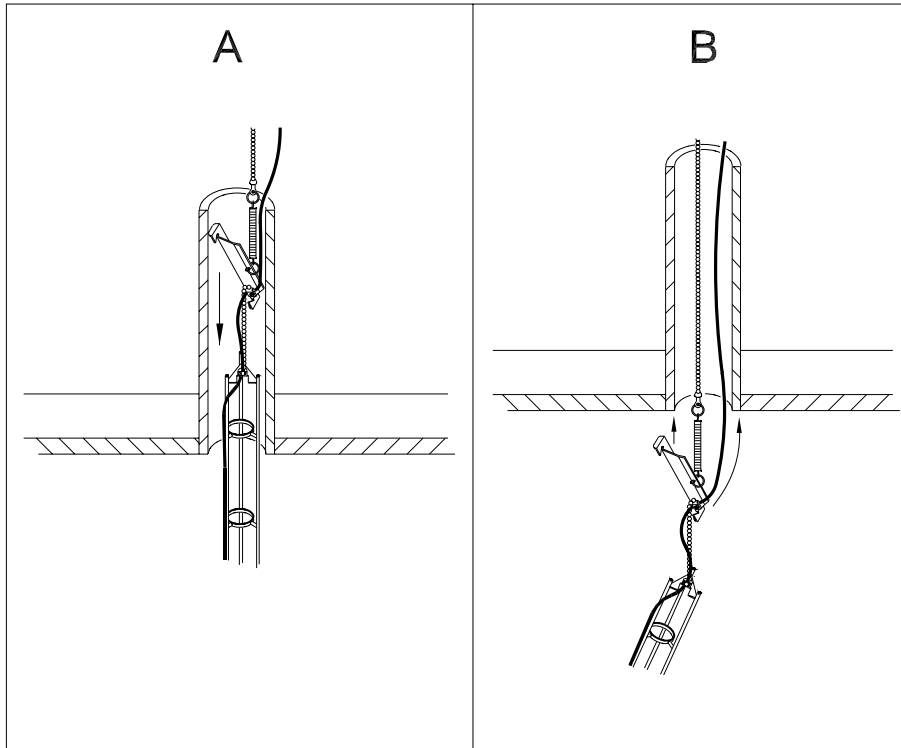

Figure 4.7 A & B Lowering the Sensor into Tank & Securing the Straight Hanger into Position

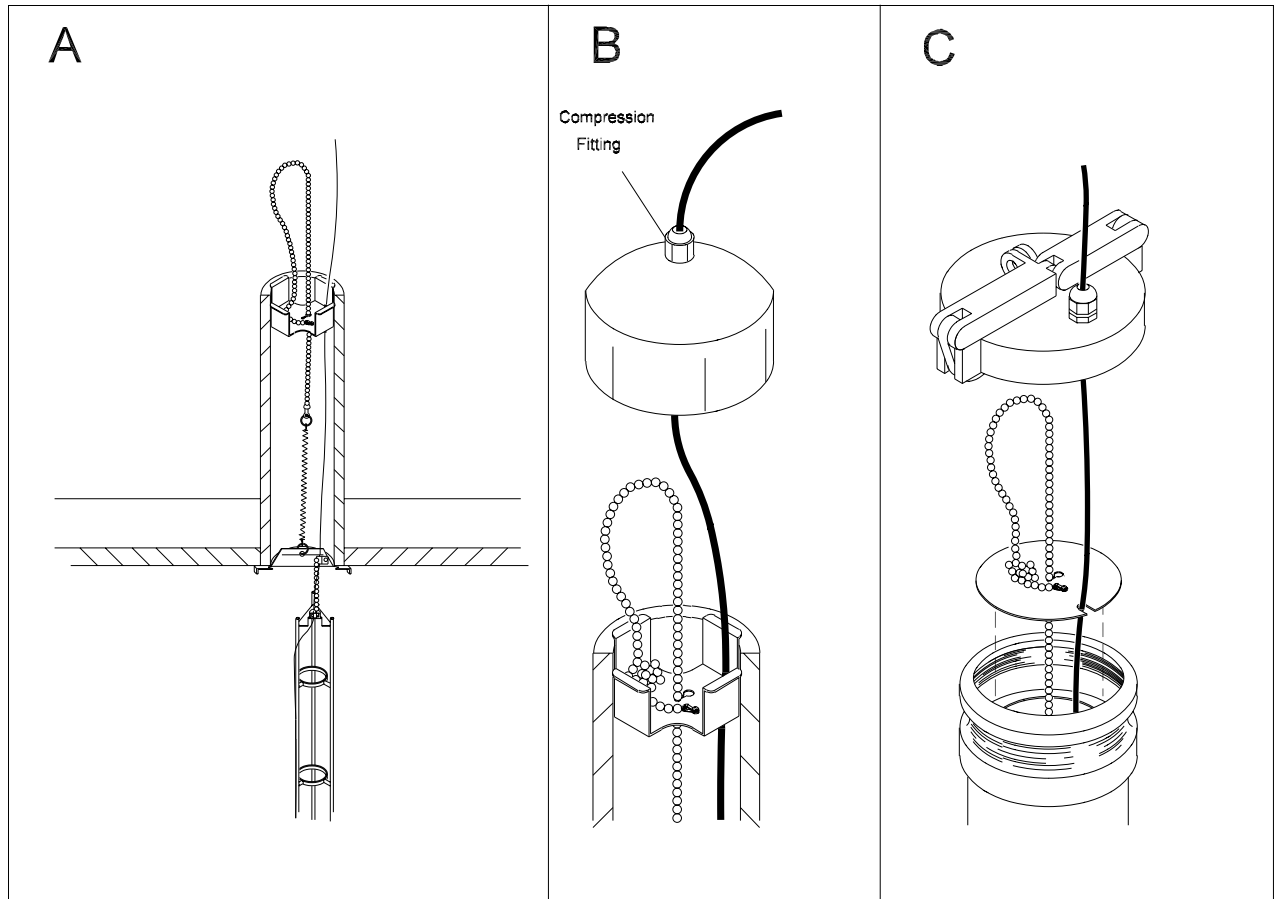

Figure 4.8 A, B, and C: Compression Fitting Used for Existing Riser Cap

Step 6: Pull on the chain until the spring has extended 3-in to 4-in (7.6-10.1cm) or 9 to 13 chain links to create tension, as shown in *figure 4.8A*. Slide the chain in the slot provided in the upper riser bracket. Allow the remaining chain length to dangle into the riser.

Step 7: Once installed, **GENTLY** pull upward on the Ultrasonic probe cable so as to *feel* that the sensor moves up and down freely. Make sure the sensor is hanging from the chain and not from the cable.

Step 8: Thread the Ultrasonic probe cable through the compression fitting in the cap and tighten the compression fitting around the cable. Refer to *figures 4.8 B and C*.

Notice

The feedthrough assembly attached to the Ultrasonic probe cable should be used, unless an existing compression fitting is available that is able to seal properly around the cable.

When installing the riser cap, be sure not to twist or pull on the Ultrasonic probe cable. The sensor MUST hang by the chain and NOT the cable.

Installing the Feedthrough Assembly in an Existing Riser Cap

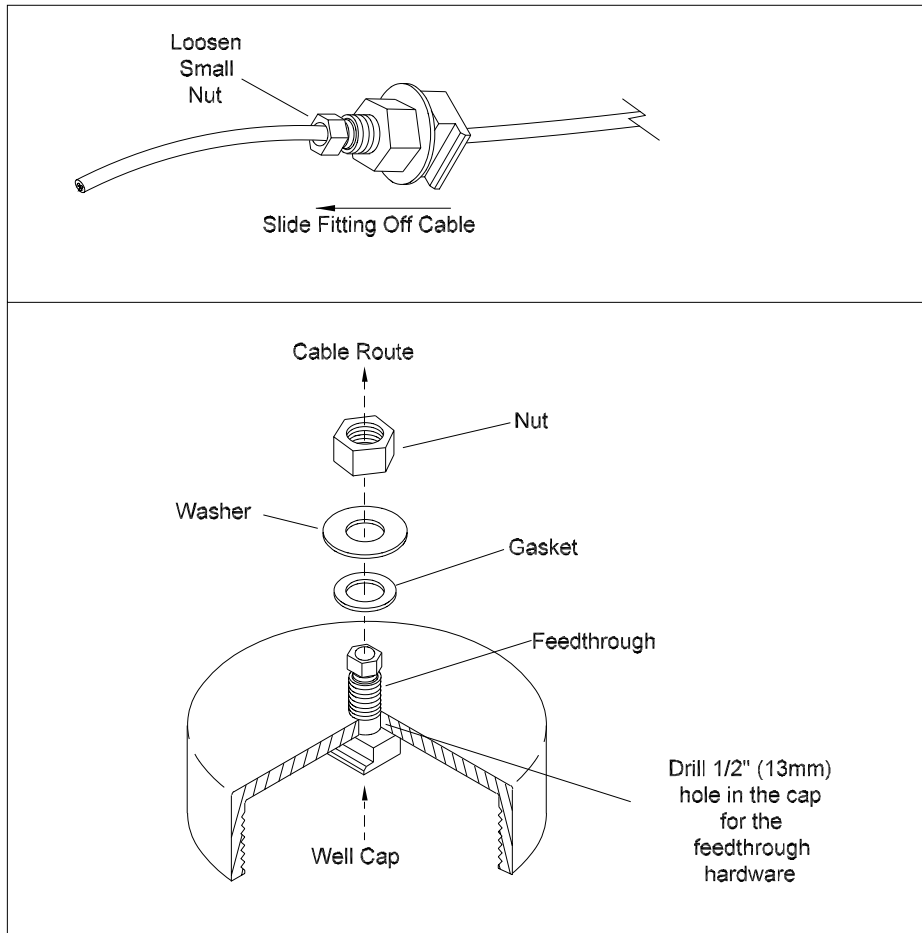

Figure 4.9 A & B Removing and Installing Feedthrough Assembly in Existing Riser Cap

Connecting the Ultrasonic probe to the Interconnect Cable

A waterproof connector housing is supplied with each Ultrasonic probe for connecting to the interconnect cable. The connector board provides a secure, low impedance connection while the housing protects the wires from corrosion. The following steps describe the installation of the connector board and housing. Refer to *figure 4.10* when performing steps 1 through 10.

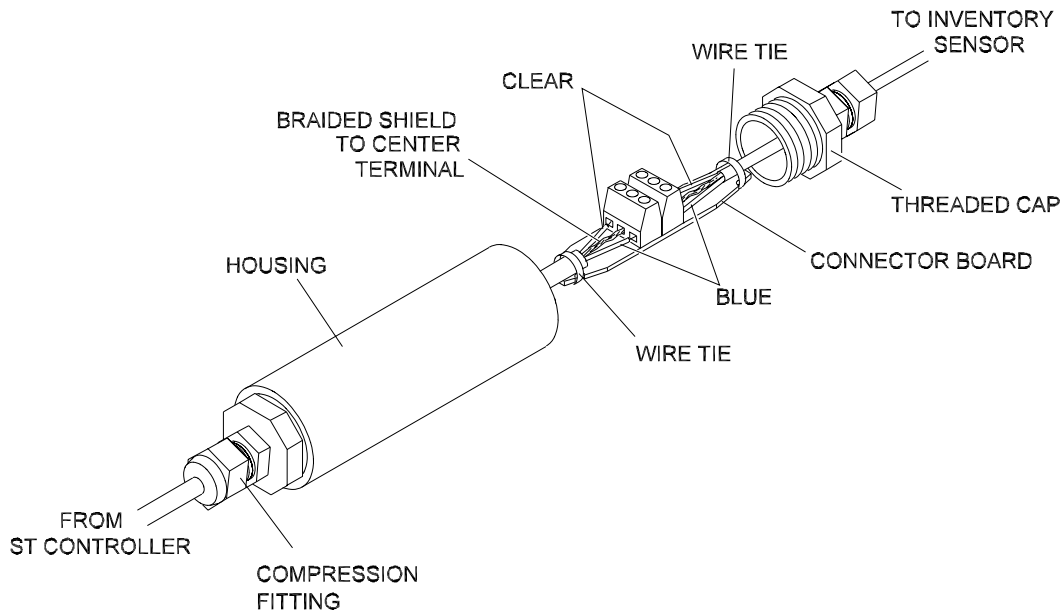

Figure 4.10 Connector Board and Housing

- Step 1:** Remove the threaded end cap (not the compression fitting) from the housing.
- Step 2:** Feed the cables through the compression fittings in each threaded cap. Pull enough cable through one threaded cap to accommodate sliding the housing over it.
- Step 3:** Strip the outer jacket of both the interconnect and Ultrasonic probe cables $\frac{3}{4}$ in(2cm).
- Step 4:** Pull back the braided shielding, on both cables, and twist to form a third conductor.
- Step 5:** Strip the insulation on the remaining conductors $\frac{1}{8}$ in(3mm).
- Step 6:** Connect the braided shielding to the center terminals of both connectors. Connect the remaining conductors to the connectors (Blue with Blue, Clear with Clear).
- Step 7:** With the wire ties provided, strap each cable securely to the connector board. This will provide strain relief for the connections.
- Step 8:** Pull the connector board into the housing and insert the desiccant pouches.

Step 9: Apply UL-Classified pipe sealant to the threads of the threaded cap and thread it into the housing.

Step 10: Tighten the compression fittings around the cables to ensure moisture does not enter the connector housing. Firm hand pressure is enough to seal. **DO NOT** over-tighten.

Installing an Ultrasonic Probe in a Delivery Riser

- Installation Considerations
- Preparing the tank
- Preparing the delivery riser
- Sizing instructions for Ultrasonic probes using an offset hanger
- Sizing the offset hanger
- Preparing Ultrasonic probe for Installation in Delivery Riser
- Installing Ultrasonic probe
- Sensor Deployment
- Modification and Installation of the Drop Tube

There are a few things to be considered when installing a probe into a delivery riser using an offset hanger. The existing delivery riser, fill pipe, containment sump, and probe cable need preparation. In addition, the drop tube will need to be replaced. If sawcuts and direct bury cable are being used, the riser and possibly the containment sump will require openings for the cable to pass through. See *figure 4.12*.

Notice	When a containment sump is used, consult the containment sump manufacturer for proper installation procedures.
---------------	--

Installation Considerations

When reviewing the installation considerations, refer to *figure 4.11*.

- The inside diameter of the riser must be 4-in(10cm) or greater for ease of installing and un-installing.
- The riser pipe length must be greater than 18-in(45cm) and less than 48-in(120cm). If the riser pipe does not fall between these dimensions, contact Red Jacket for special instructions.
- The riser pipe cannot extend more than 1½ in(3.8cm) inside the tank.
- The distance from the center of the riser pipe to the end of the tank must be greater than 9-in(23cm).
- A minimum of 20-in(50cm) must be left between the center of the fill riser and the next tank fitting in the direction toward the center of the tank.
- A distance of 48-in(120cm) between the center of the fill riser and the pump is recommended.

Tank preparations and modifications

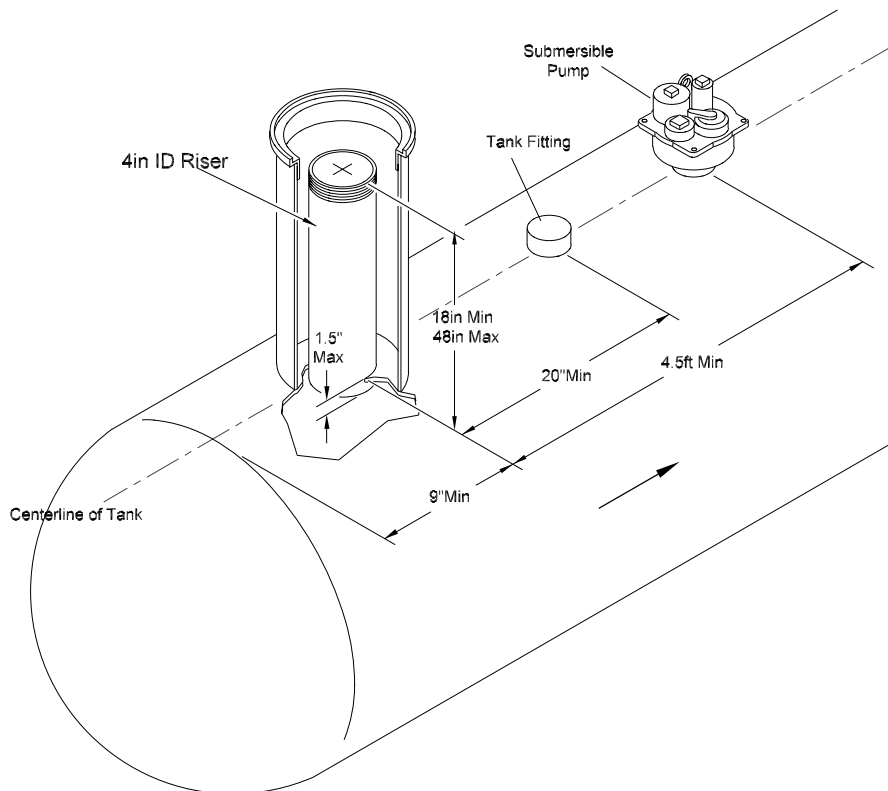

Figure 4.11 Top View of Tank

Access hole in sump must be sealed to maintain spill containment

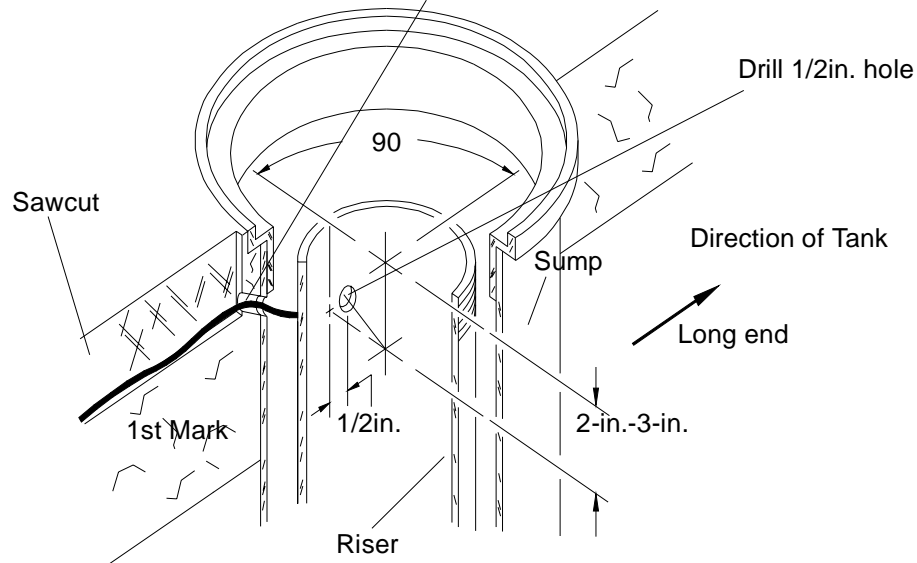

Figure 4.12 Modifications to the Riser

Step 1: If preparing an installation using a sawcut and direct bury cable, enter as low as possible in the sump to ensure the manway lid does not crush the cable. This can be accomplished most easily by stopping the sawcut just short of the sump collar. Drill a $\frac{1}{4}$ in to $\frac{3}{8}$ in (9.5 - 6.3mm) hole, at a downward angle, through the sump wall.

Notice

If the riser pipe has a spill containment sump, a seal must be made around the interconnect cable where it passes through the wall.

Step 2: Find the point on the riser that is at a right angle, (90 degrees), to the long direction of the tank. From this point, make a mark 3-4 in (7.5-10cm) down from the top of the riser. **DO NOT DRILL HERE.** Refer to *figure 4.12* when performing this step.

Step 3: Measure $\frac{1}{2}$ in (13mm), from the mark made in step 2, toward the center of the tank, and place another mark. At this point, drill a $\frac{1}{2}$ in (13mm) hole. This hole location will ensure the Ultrasonic probe will be positioned at the center line of the tank.

Step 4: Remove the feedthrough assembly from the Ultrasonic probe cable and install it into the riser with the lip in facing upward. Refer to *figure 4.13*.

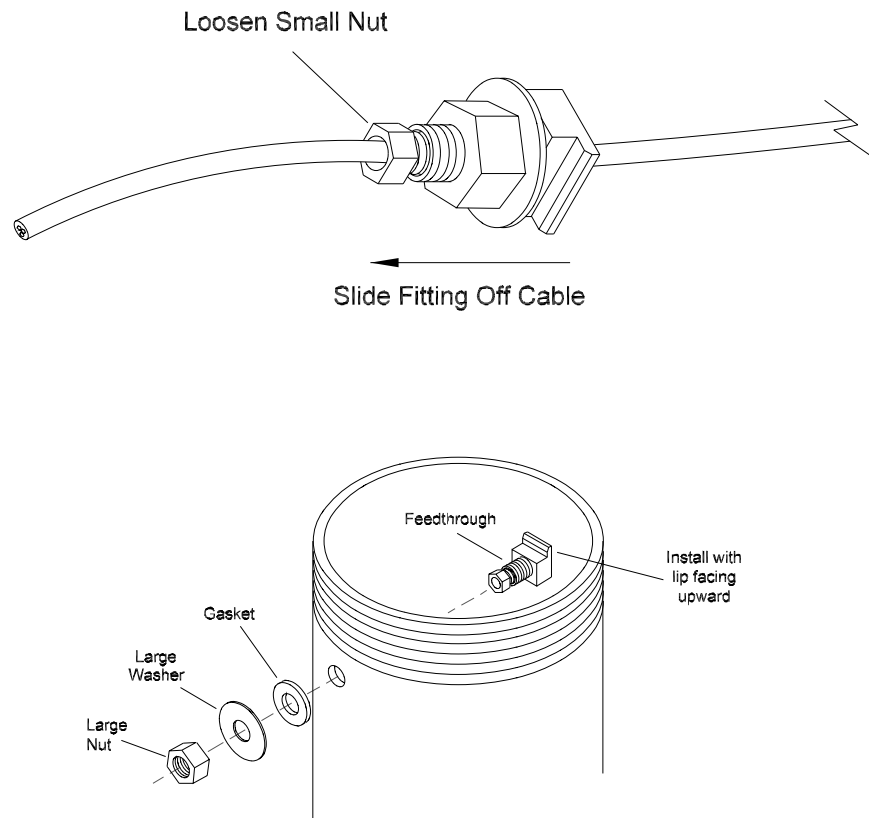

Figure 4.13 Removal and Installation of Feedthrough Assembly

Sizing Instructions for Ultrasonic Probes Using an Offset Hanger

WARN- ING!

It is important to take accurate measurements to make sure the Ultrasonic probe **DOES NOT REST ON THE BOTTOM OF THE TANK!**

The Ultrasonic probe should be installed high enough off the bottom that only the water float touches the tank's bottom. The Ultrasonic probe must be free to move so it remains perpendicular to the surface of the liquid in the tank.

Step 1: Use an undamaged tank stick to measure the distance from the bottom of the tank to the top edge of the feedthrough assembly, measurement (A). This is shown in *figure 4.14*.

Notice

It is normal for tank sticks to become worn when used daily. Inspect the tank stick for wear and complete length before using.

Measurements:

$$(A - B = C)$$

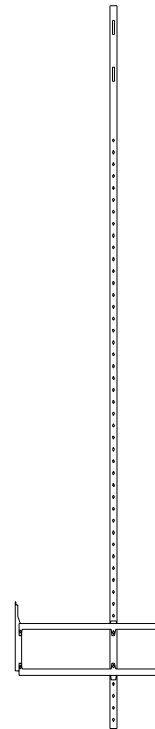
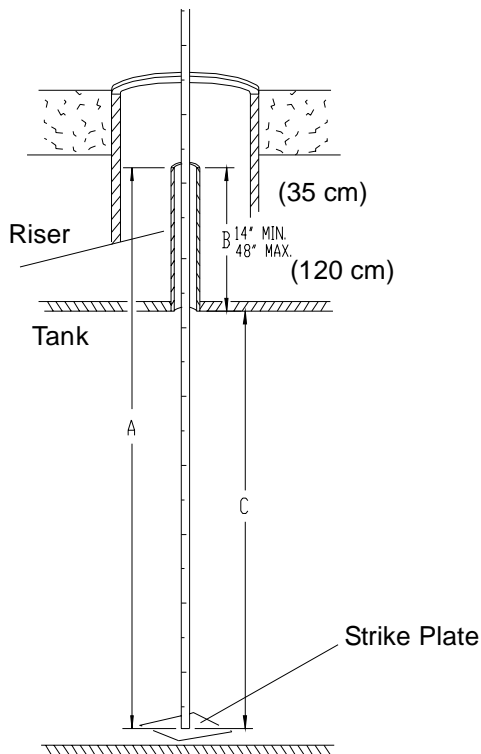
Calculations used to determine hanger clearance (C - D = E)

D=offset hanger clearance is
8-in. (20.3cm)

Figure 4.14 Measurements for Mounting Ultrasonic probe in Tank

Step 2: Use a rigid measuring tape to measure the length of the riser from the bottom, inside edge to the top edge of the feedthrough assembly, measurement (**B**). Refer to *figure 4.14*.

Notice

The riser length required for this installation is a minimum of 18-in. and a maximum of 48-in. If the riser is longer than 48-in., contact Red Jacket sales for a special chain length.

Step 3: *Subtract* measurement (**B**) from measurement (**A**) to calculate the actual inside diameter of the tank measurement (**C**), ($A-B=C$). This is demonstrated in *figure 4.14*.

Step 4: If using the offset hanger, subtract 8-in.(20.3 cm) from (**C**), ($C - 8''=D$). If using the straight hanger refer to the section titled *Installation of Ultrasonic probe in Dedicated Riser* earlier in this chapter.

Step 5: Round calculation (**D**) down to the nearest available probe length and refer to the section, *Part Numbers for Ultrasonic probes* in **Appendix A: Parts List** of this manual.

Caution

DO NOT over-tighten the screw that attaches the lower riser bracket to the end plate or hanger channel. Over-tightening the pivot points will cause the hanger to buckle and the sensor may be irretrievable.

Sizing the Offset Hanger

Step 1: Add 2-in.(5.1cm) to the (**B**) measurement (see *figure 4.15*) and use this distance to relocate the crossarm. Remove crossarm and relocate it with the top mounting hole at this measurement. If the measurement falls between two holes select the higher position.

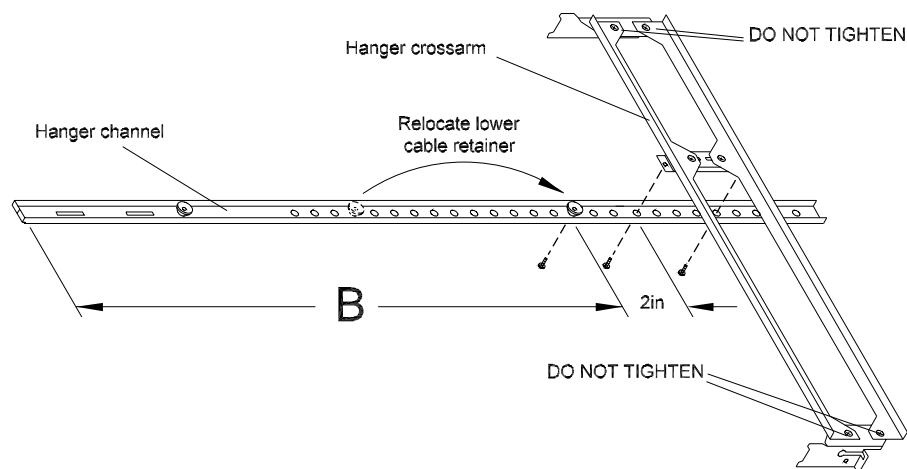

Figure 4.15 Relocation of Hanger Crossarm

Step 2: Relocate lower cable retainer to measurement (**B**).

Step 3: It may be helpful to install the hanger (without the probe) as a trial installation to verify that all measurements are correct. Attach the probe installation tool to the rectangular slots in the hanger channel and tighten it by rotating the tool's upper knob, clockwise. Fold crossarm as indicated in *figure 4.16*.

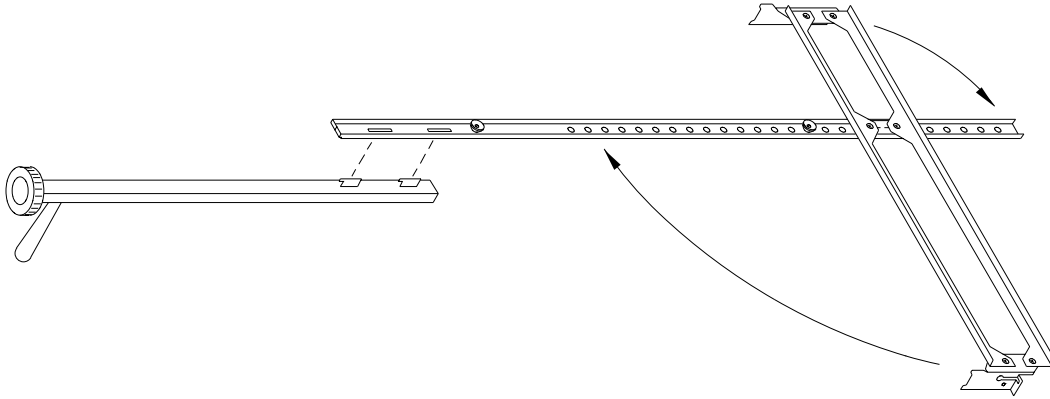

Figure 4.16 Installation Tool Connection to Offset Hanger

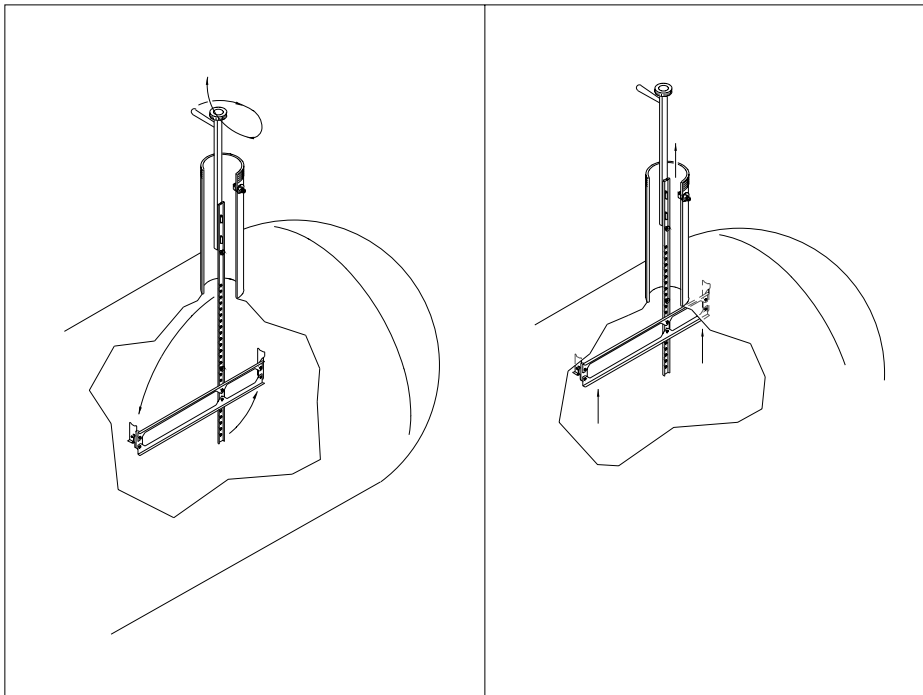

Figure 4.17 Lowering the Offset Hanger into Tank

Step 4: Lower the folded hanger into the fill pipe until the crossarm is below the top of the tank as depicted in *figure 4.17*. A **quick** twisting motion will force the crossarm out-

ward. **Quickly** pull up so the short end of the crossarm is caught by the top of the tank as shown in *figure 4.18*. If the crossarm folds back up, remove hanger and refold crossarm as indicated in *figure 4.16*. Repeat step 4.

Caution

DO NOT apply excessive force when pulling up on the installation tool. This will cause the offset hanger to bend out of shape and the damage will be *irreparable*. If the hanger does not hook on the feedthrough with relative ease, the crossarm may be mounted too high in the channel and must be lowered. If damage occurs, call the Red Jacket representative before continuing. Proceed with Step 5.

Step 5: Once the hanger is deployed, pull up on the installation tool until the spring mechanism compresses to about $\frac{2}{3}$ of its travel. Hook the channel over the lip on the feedthrough assembly. If the hanger hangs loosely on the feedthrough lip; the crossarm is too low on the channel and must be raised by one hole.

Step 6: Apply lateral force to the hanger by pulling on the installation tool. If the crossarm appears to be tight against the top of the tank, and the hanger is firmly hooked on the feedthrough assembly, then the hanger is adjusted properly (see *figure 4.18*).

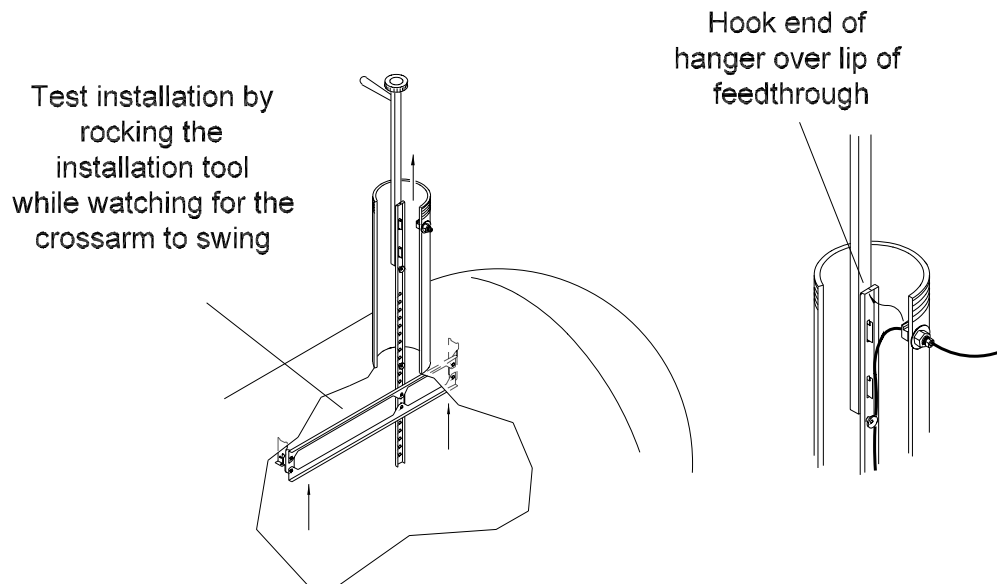

Figure 4.18 Deploying Offset Hanger

Step 7: Remove the hanger from the riser by unhooking the channel from the feedthrough and lowering it so that the crossarm folds. Remove the hanger from the delivery riser. Refer to *figure 4.19*.

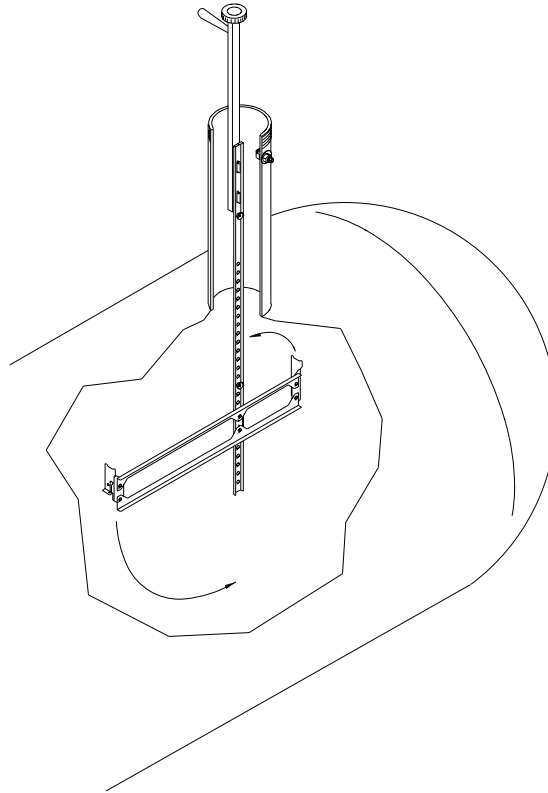

Figure 4.19 Offset Hanger Removal

Preparing the Ultrasonic Probe for Installation in Delivery Riser

Caution

Improper alignment of the water float assembly will cause incorrect readings. The water float guide should be aligned parallel with the vertical rods of the sensor. This can be accomplished by eyeing the alignment and bending by hand. If the water float tilts inward too much (0.5-in. or 13-mm) the ultrasonic reflection from the water float bracket will degrade sensor performance.

Step 1: Lay the Ultrasonic probe on level ground and install the water float (see *figure 4.20*).

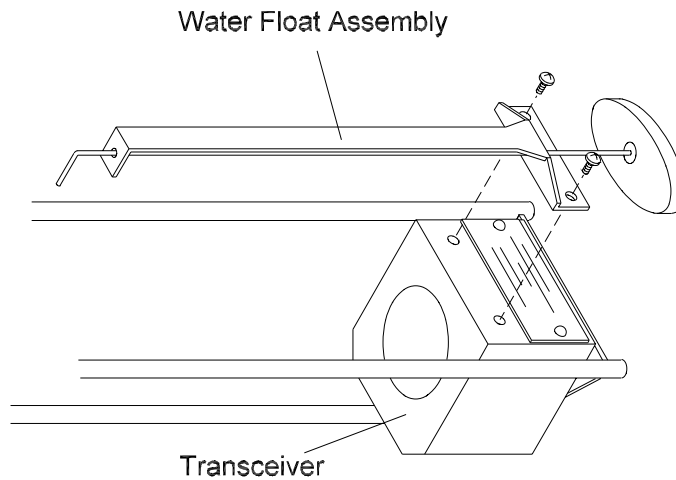

Figure 4.20 Water Float Installation for Use in a Delivery Riser

Notice

For applications involving kerosene or diesel, install the diesel clip on the water float. If a clip is required refer to *figure 4.21*.

Specific Gravity of Product	Number of Clips
Gasoline - 0.69 to 0.78	0
Kerosene/Diesel - 0.78 to 0.87	1

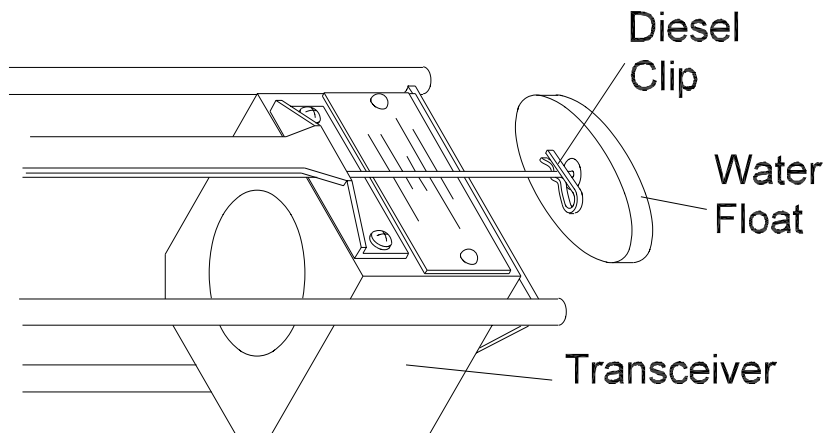

Figure 4.21 Diesel Clip Attachment for Use in Delivery Riser

Installation of Ultrasonic probe

Step 1: Loosen, then swing the cable/chain retainer away from the slot, at the crossarm end plate as shown in *figure 4.22*.

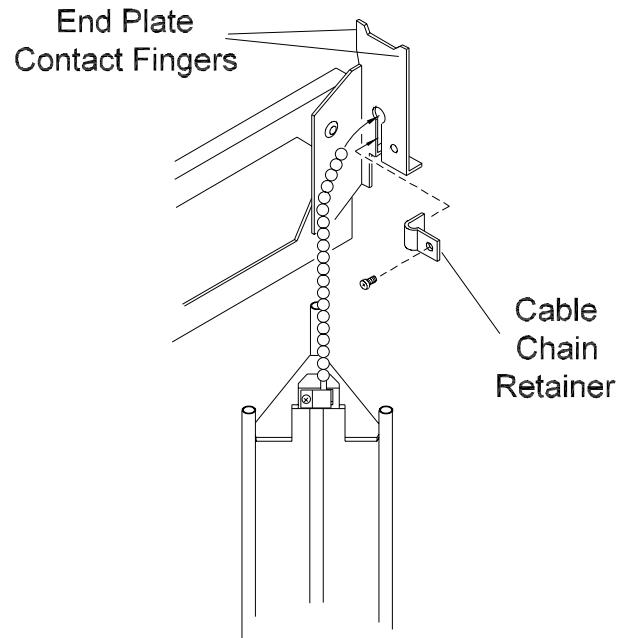

Figure 4.22 Removing the Cable/Chain Retainer

Step 2: To adjust the correct overall length, lay a tank stick on level ground next to the Ultrasonic probe and offset hanger.

Step 3: Attach the chain to the endplate so the bottom of the transceiver block is at the 2-in. mark on the stick and the endplate contact fingers are at the (C) measurement (see *figure 4.23*).

Notice

The top of the sensor can be no closer than 1-in. from the lowest point of the crossarm. Refer to figure 4.23.

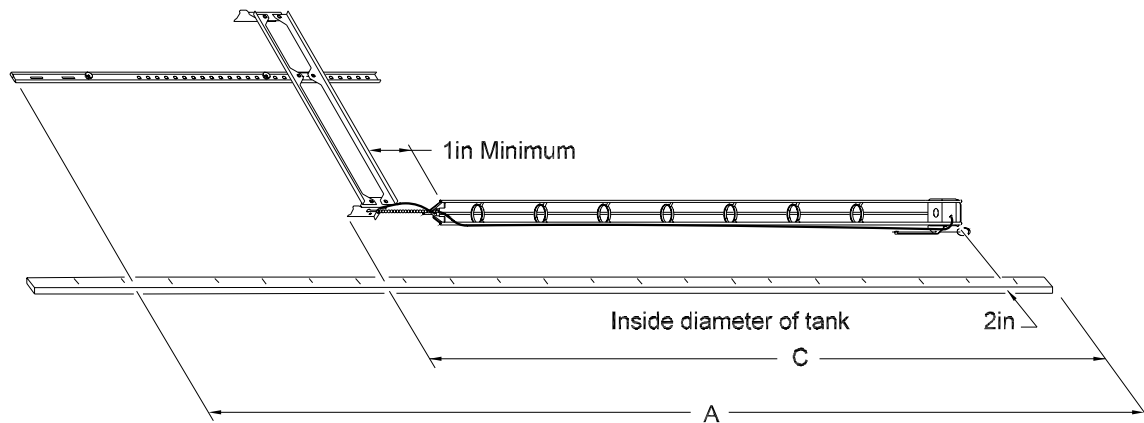

Figure 4.23 Measuring for Offset Hanger Installation

Notice

For Ultrasonic probes longer than 8 feet, perform the following sub-steps prior to deployment.

- Count the number of chain links between the top of the Ultrasonic probe and the endplate. Detach the sensor from the endplate.
- Insert the Ultrasonic probe into the tank. Use a wooden dowel to temporarily support the sensor by passing it through the sensor below the top plate. **DO NOT** support the sensor on any of its rings.
- Reattach the sensor to the endplate of the offset hanger leaving the same number of links between the sensor and the hanger as determined in substep a.

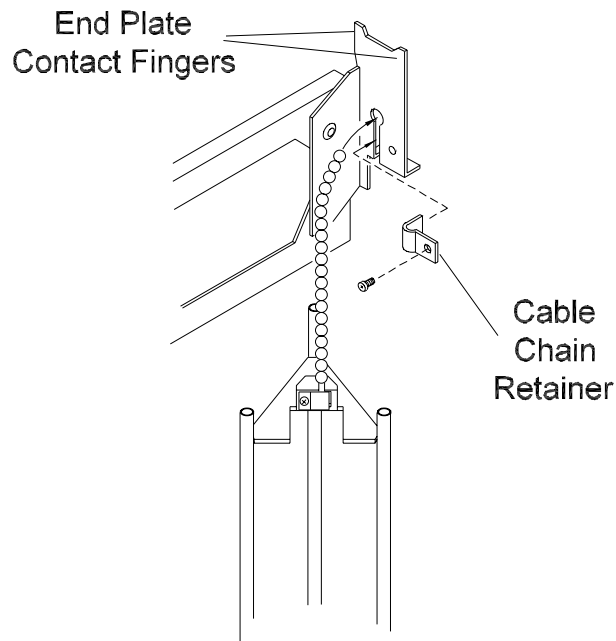

Figure 4.24 Attaching the Cable and Chain to the End Plate

Step 4: Route the cable through the cable/chain retainer. Turn the retainer's screw until the retainer can no longer back out of the channel.

Notice	<i>DO NOT</i> over-tighten the cable/chain retainer. The cable must be able to slide easily.
---------------	--

Notice	<i>DO NOT</i> weave the cable through the hanger crossarms. The <i>scissor</i> action during installation and un-installation will cut the cable. Leave enough slack in the cable to allow the hanger to close up for installation. See <i>figure 4.25</i> .
---------------	--

Step 5: Route the sensor cable through the hanger channel behind the cable retaining clips as shown in *figure 4.25*.

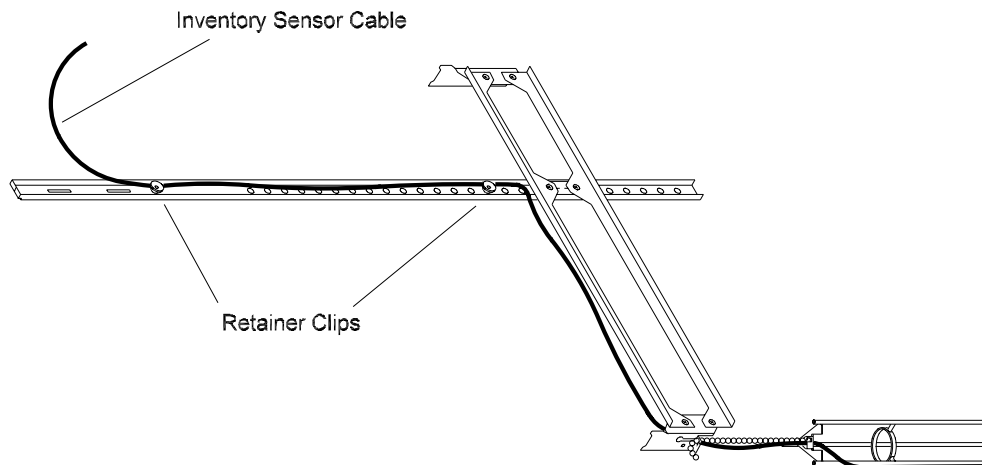

Figure 4.25 Ultrasonic probe Cable Routing with Offset Hanger

Step 6: Attach and lock the Ultrasonic probe installation tool onto the hanger channel and fold crossarm. Refer to *figure 4.26*.

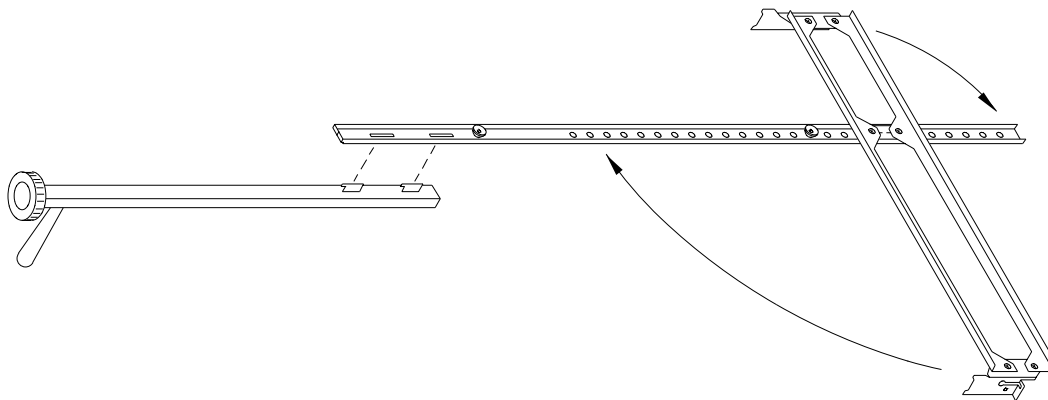

Figure 4.26 Attaching the sensor installation tool

Notice

Be careful not to bend the water float when lowering it into the riser. A damaged water float will not accurately register the water level.

Notice

Avoid pulling on the sensor cable during sensor installation because the sensor cable may pull out of the retainer clips making it impossible to keep the cable inside the hanger channel.

Step 1: Fold up the long end of the hanger against the channel as shown in *figure 4.27*. Lower hanger and sensor carefully into riser until the assembly unfolds.

Step 2: While resting the installation tool on the riser, route the sensor cable through the feedthrough assembly mounted in the riser.

Step 3: Pull up on the installation tool until the crossarm contacts the tank. As the sensor is being raised, cable slack must be pulled through the feedthrough assembly.

Step 4: Once the crossarm makes contact, further upward motion compresses the spring in the crossarm. After the crossarm makes contact with the tank, pull up on the installation tool until the hanger channel can be lowered onto the feedthrough assembly. Since the crossarm is spring loaded, this step will be a quick “up and over” operation, and should have a “snug” feel.

Step 5: Check the installation by making sure the sensor cable stayed inside the hanger channel and by applying lateral force as shown in *figure 4.18*.

Step 6: Tighten the large outer feedthrough nut and the inner cable compression fitting to seal off the tank.

Step 7: Reinstall the riser cap.

Caution

Make sure that all feedthrough assembly hardware is tight. Loose hardware will result in an incomplete seal allowing water to enter the tank and/or produce a failing result of the vapor recovery nitrogen test.

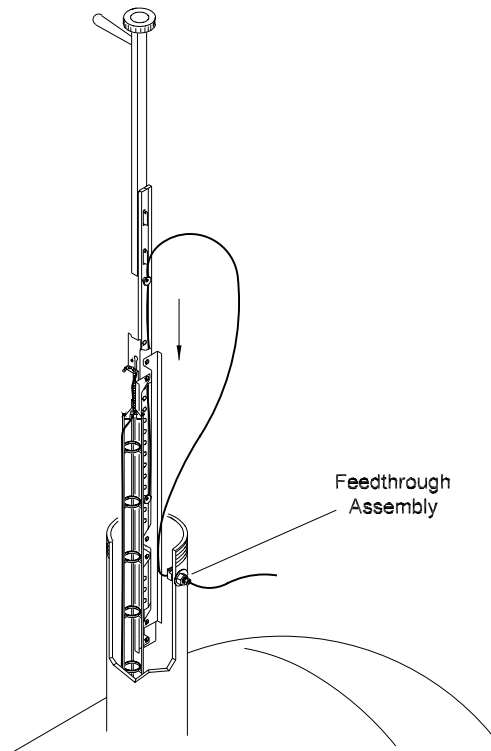

Figure 4.27 Inserting Hanger with Sensor and Routing into Riser

Modification and Installation of the Drop Tube

- Step 1:** The drop tube may have to be shortened to fit into the tank. The lowest point of the drop tube must be between 4-6" (10.1-15.2cm) of the bottom of the tank per PEI regulation RP194. Other local regulations may also apply. Refer to *figure 4.28* for corresponding (*measurement A*) and cut the tube to that length.
- Step 2:** The drop tube must be cut at a 45° angle to enhance proper operation of the ultrasonic probe. Measure 2-in. and remove material. Refer to *figure 4.28*.

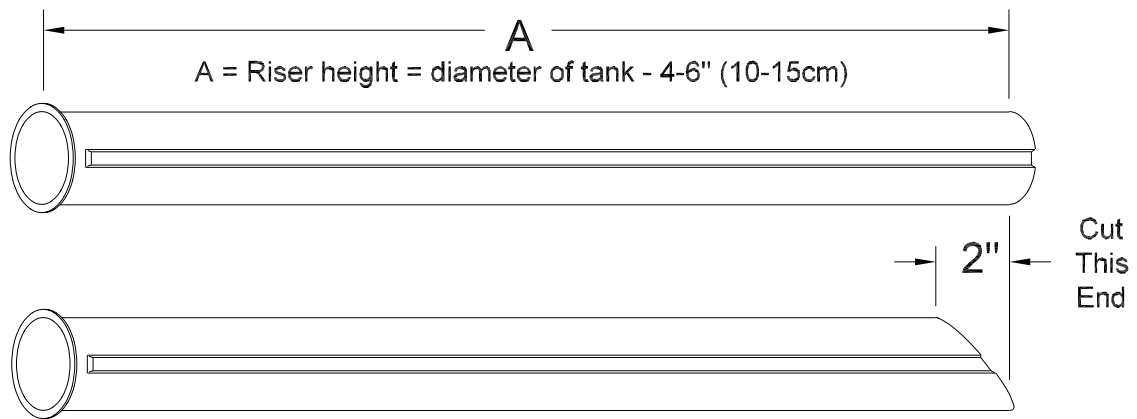

Figure 4.28 Sizing Drop Tube

Step 3: Align the groove in the drop tube with the channel of the offset hanger. Insert the drop tube until it is seated on the lip of the riser, as shown in *figure 4.28*.

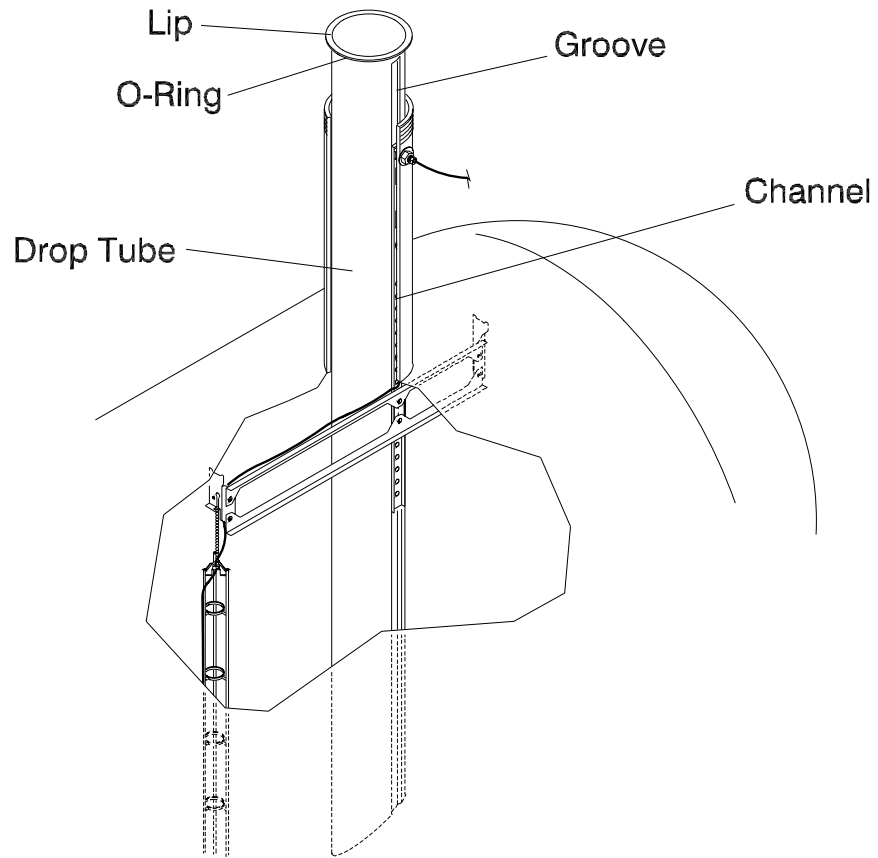

Figure 4.29 Aligning and Installing the Drop Tube

Step 4: Reinstall the riser cap.

Chapter 5: Installation of the Sonic Network Card

This Chapter explains

- Installing the Sonic network card in a Prolink chassis
- Connecting the Ultrasonic probe to the Sonic network card

Installing the Sonic network card in the Prolink chassis

The following procedure demonstrates how to install the Sonic network card into a slot in a Prolink chassis.

Step 1: Disconnect power to the Prolink chassis at the electrical panel and the On/Off switch on the Prolink chassis power supply circuit board. Open the network card access panel and select an open slot for installation. Refer to figure 5.1.

Step 2: Remove one of the conduit knockouts underneath the selected slot and install a conduit connector and conduit.

Notice	The short dividers in the lower section of the chassis may be removed for access, but MUST be reinstalled to maintain intrinsic safety and complete the installation.
---------------	---

Step 3: Remove slot cover from the selected slot.

Step 4: Slide the Sonic network card into the selected slot. Note the orientation of the card in *figure 5.1*. Make sure that the card connects completely with the backplane board. Tighten the two hold-down nuts to fully secure the card in position.

Step 5: Refer to the next section for instructions on connecting the Ultrasonic probe to the Sonic network card.

Step 6: DO NOT reconnect power to the Prolink chassis until the Ultrasonic probe is installed in the tank and all connections are made. Refer to **Chapter 4: *Installing the Ultrasonic probe.***

Step 7: When all connections are made, reconnect power to the Prolink chassis.

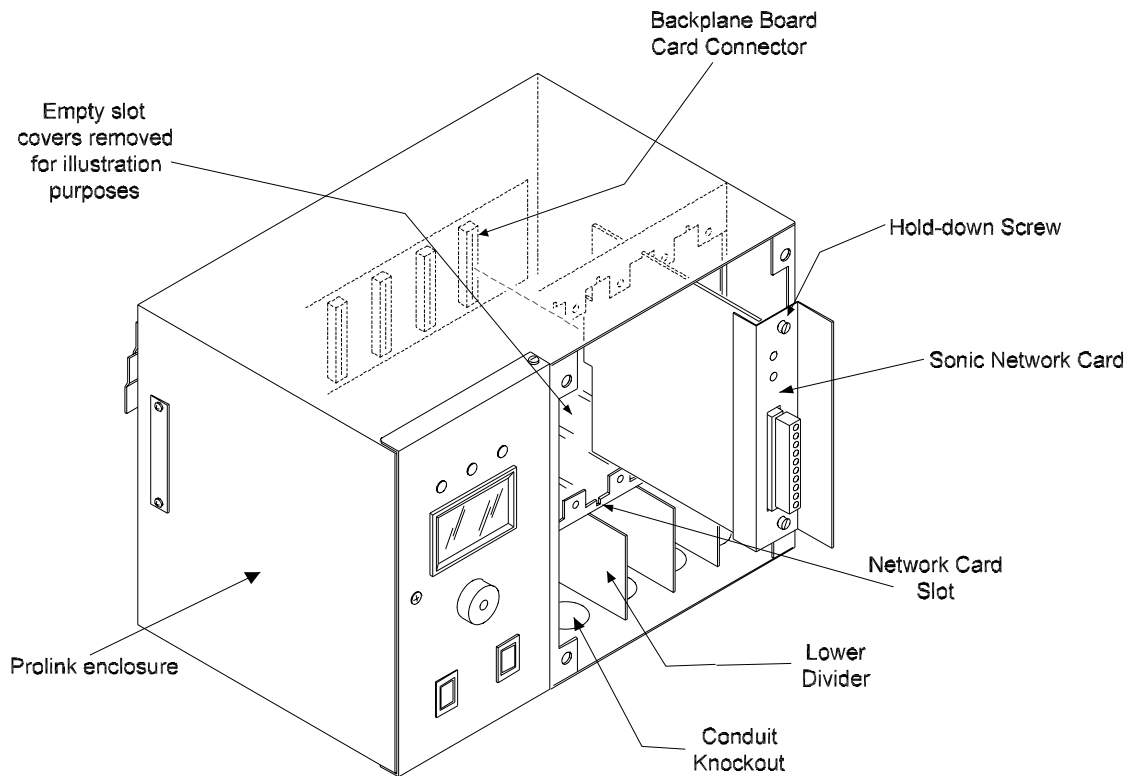

Figure 5.1 Installing the Sonic network card

Connecting the Ultrasonic Probe to the Sonic network card

Cable connections at the Sonic network card

This is the procedure for making the cable connections at the Sonic network card in a Prolink chassis. Refer to figure 5.2.

Step 1: Strip the outer casing of the cable back 1.5 inches.

Step 2: Select an open channel and connect the **SHIELD** conductor to the **G** terminal

Step 3: Connect the **BLUE** and **WHITE/CLEAR** conductors to the **A** and **B** terminals.

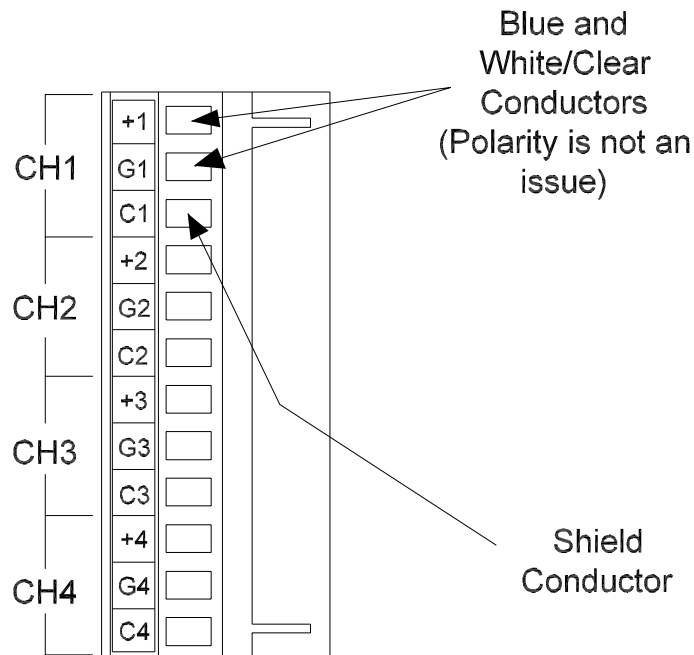

Figure 5.2 Connections at the Sonic network card

Step 4: Replace the network card cover on the Prolink chassis.

Chapter 6: Pathway Plus Setup

This Chapter Explains

- Sonic Network Card Setup in Pathway

Sonic Network Card Setup in Pathway



Wink: Click on this button to blink the service LED on the node. This is helpful in situations where there is more than one network card of the same type installed in the same chassis. Blinking this LED will identify the specific card that is being configured.

The **node name** represents the current name of the card you will be working with. The **neuron id** is a permanent number, and it does not change.

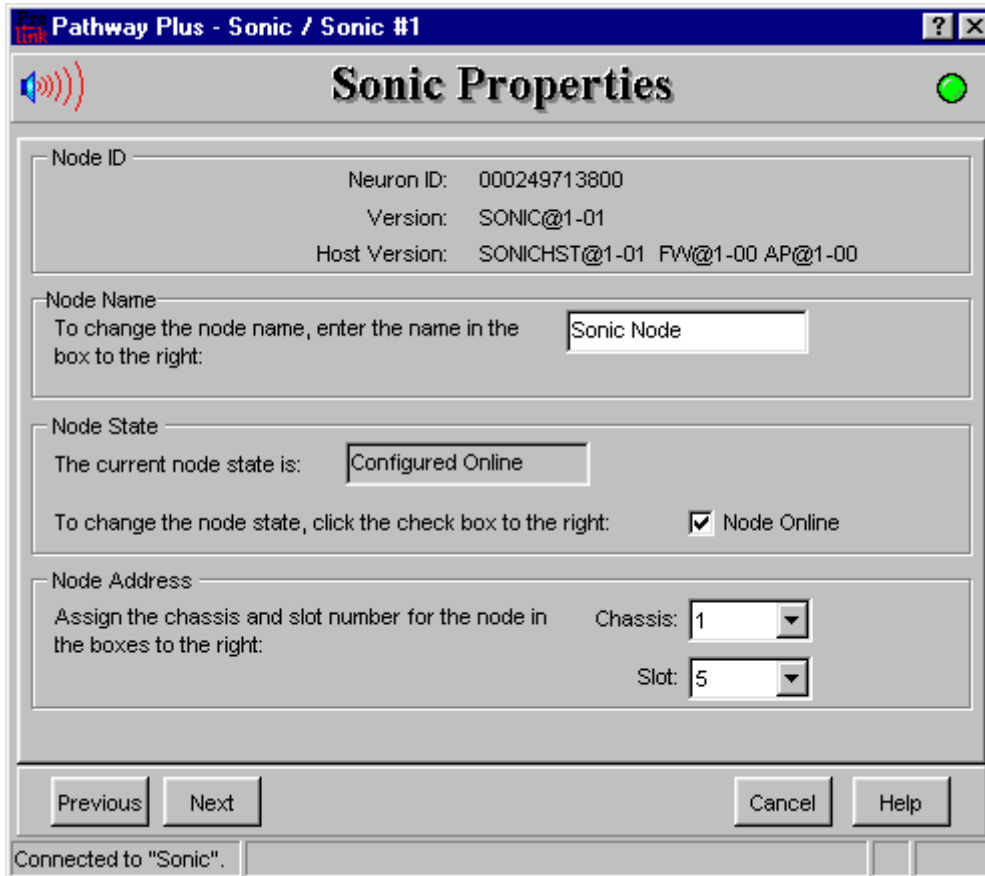

Node ID: Neuron ID: The neuron ID is a read only field that contains a unique set of numbers and letters that identify the device. (No two Prolink devices have the same neuron ID) The neuron ID should match the printed label found on the device as well as the corresponding label on the configuration worksheet.

Node Name: Each device has a default name assigned to it. If you want to change this name, enter it in this field. The name in this field will be displayed by Pathway Plus anywhere this node appears. (Max. of 12 characters)

Node State: Current Node State: This is a read only field that shows the current node state.

Online Configured-This is the normal operating state. In this case the application is loaded, configured, and connected to the Prolink network.

Soft Offline-In this case the application is loaded and configured, however the application is not running. This state would be used when performing service at the station to prevent this node from going into alarm. For example, a Sonic node might be taken offline to allow the Sonic probe to be pulled from the tank for inspection or replacement without sending an alarm to the network.

Node Online: In most cases this check box should remain selected. To take the node offline to allow service work to be performed at the station, uncheck this box.

Node Address: The address is used to identify which chassis and slot the card is in. It identifies the physical location.

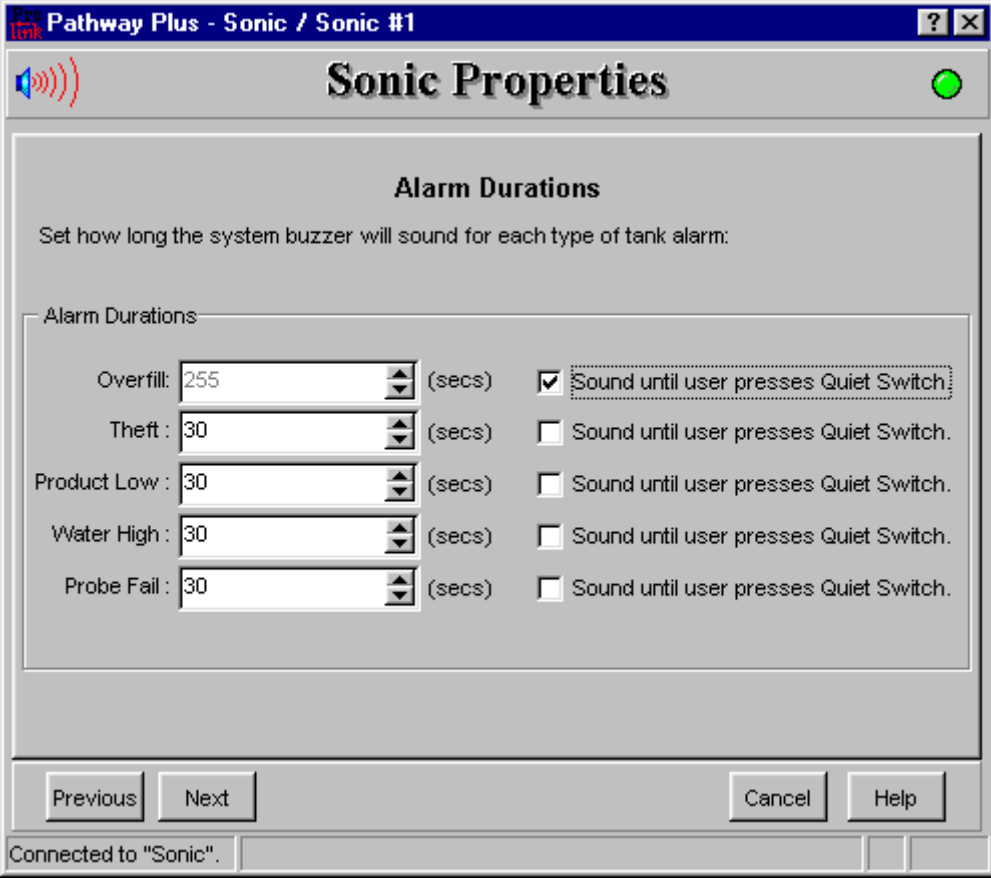

This section allows the user to set how long the system buzzer will sound for each type of tank alarm. By checking the checkbox to the right of each alarm duration, the installer can specify that the alarm should sound indefinitely until acknowledged by pressing the 'Quiet' button.

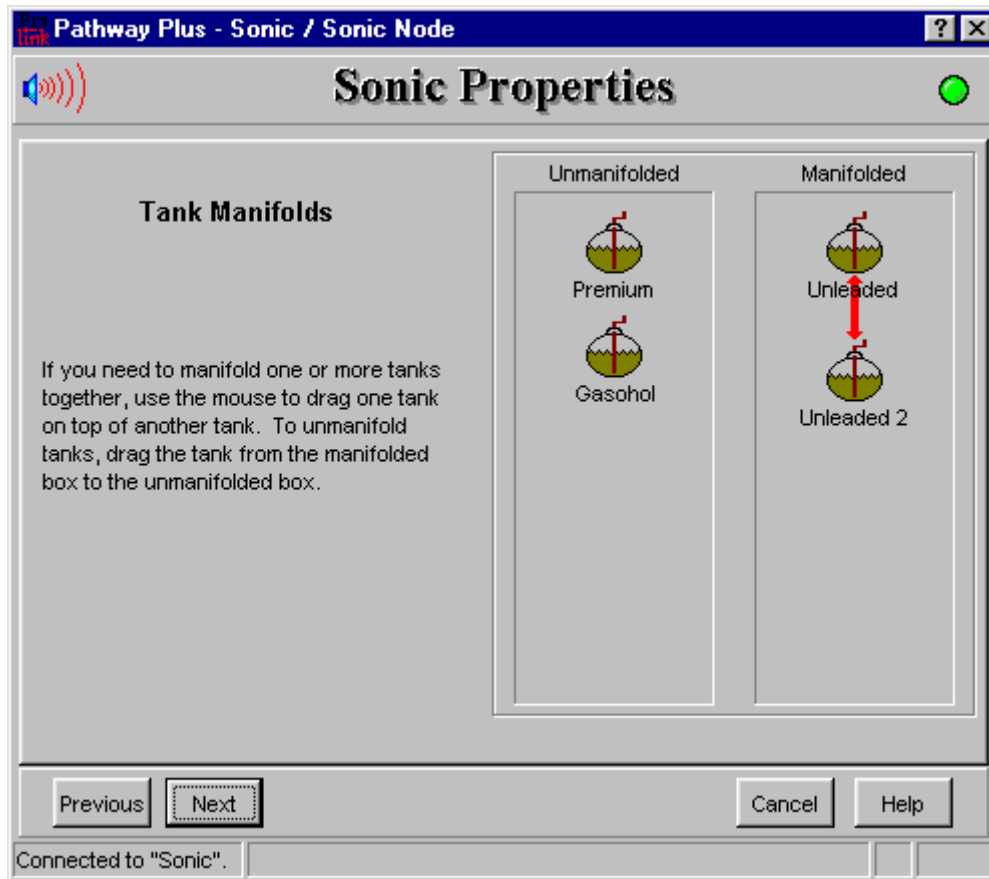

This section allows the user to manifold and unmanifold tanks, as well as add tanks to the manifold. Note that all tanks manifolded together must be wired up to the same Sonic Network card.

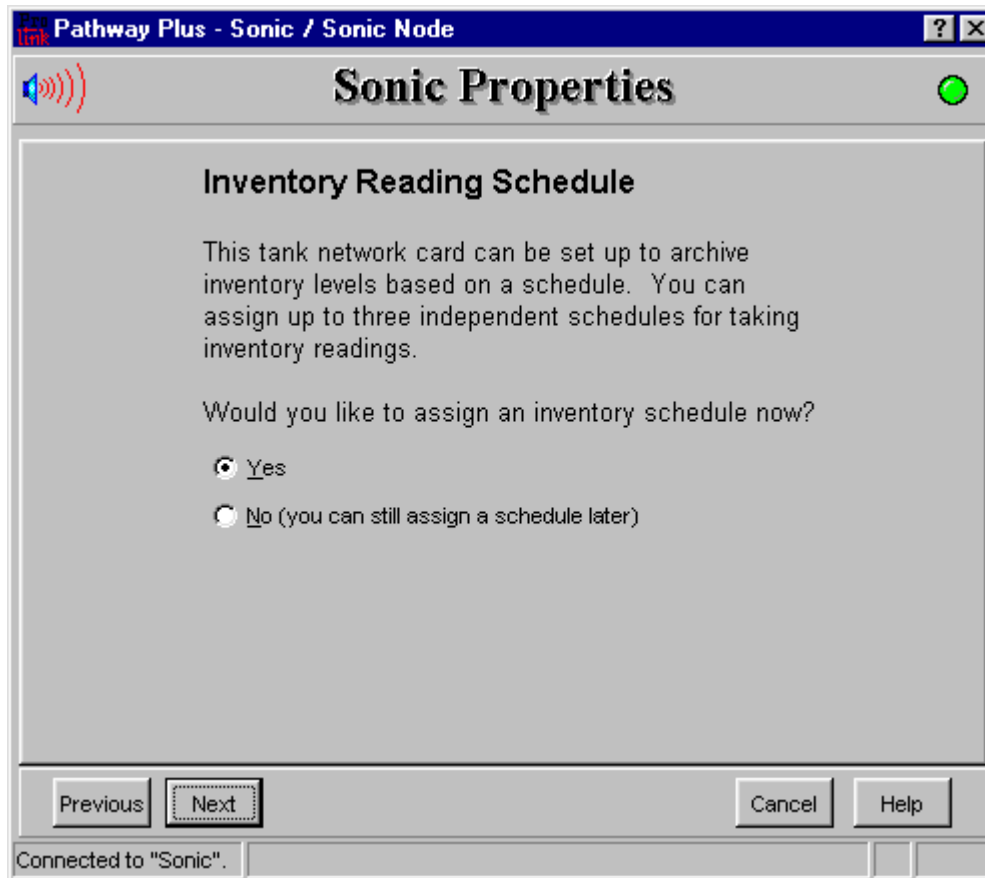

This is where the user has the choice of assigning an inventory schedule or not. This card can be set up to archive inventory levels based on a schedule. The user can assign up to three independent schedules for taking inventory readings.

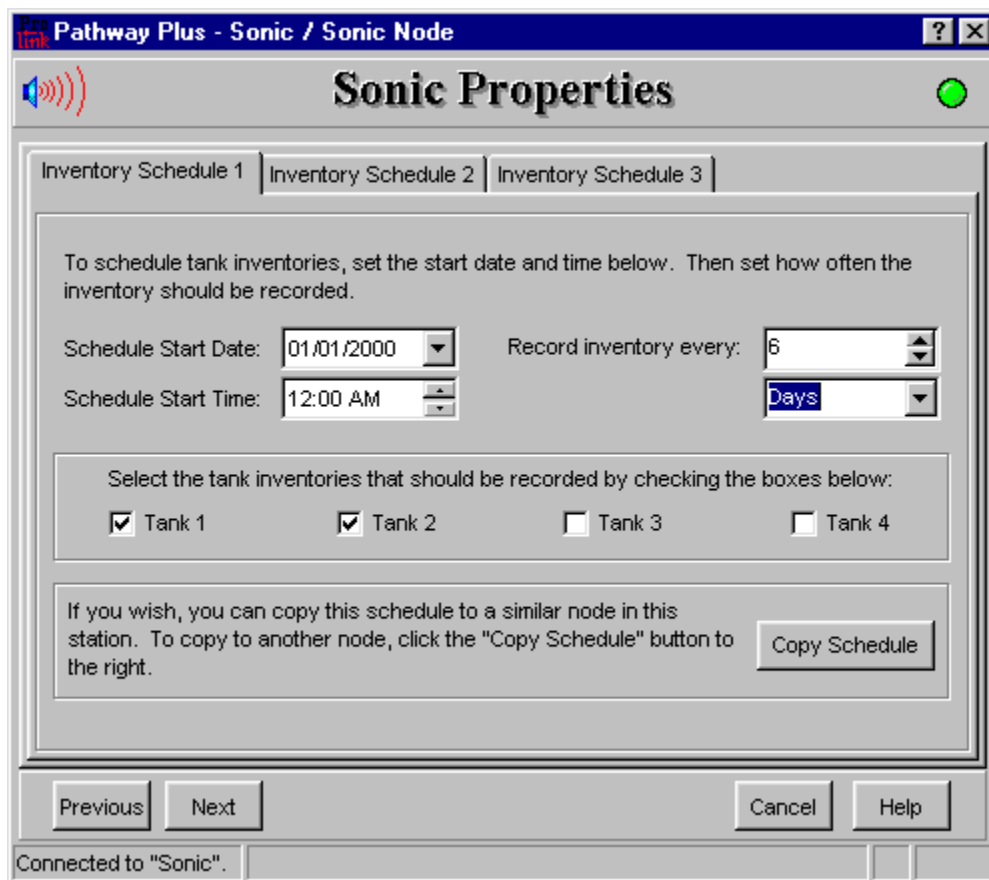

Inventory Schedule #1:

Schedule Start Date: The user can set the date of when they want inventory to begin.

Schedule Start Time: The user can set the time of when they want inventory to begin.

The user also has the choice of how often they want inventory checked. You can make this decision by putting your choice in the 'record inventory every' selections boxes.

The user also has the ability and option to choose which tank inventories should be recorded by checking the boxes that apply.

Copy Schedule: Allows the user to copy this schedule to a similar node in this station. To copy to another node, click on 'Copy Schedule.'

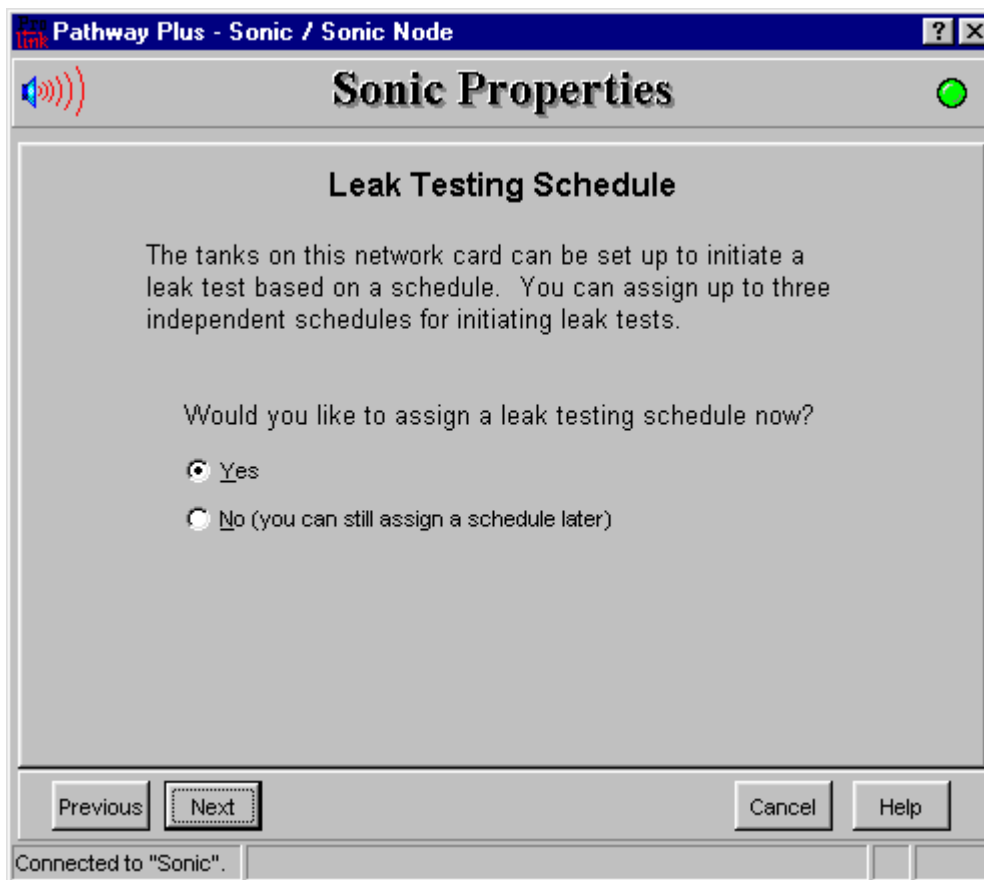

This is where the user can assign a leak testing schedule. The card can be set up to initiate a leak test based on a schedule. The user can assign up to three independent schedules for initiating leak tests. In order for scheduled leak detection to run according to the schedules, each participating tank must be set to 'scheduled' leak detection mode in the dialogs that follow. If 'Auto' or 'Facility Closed' leak detection is desired, bypass the schedule setup by selecting 'No' above.

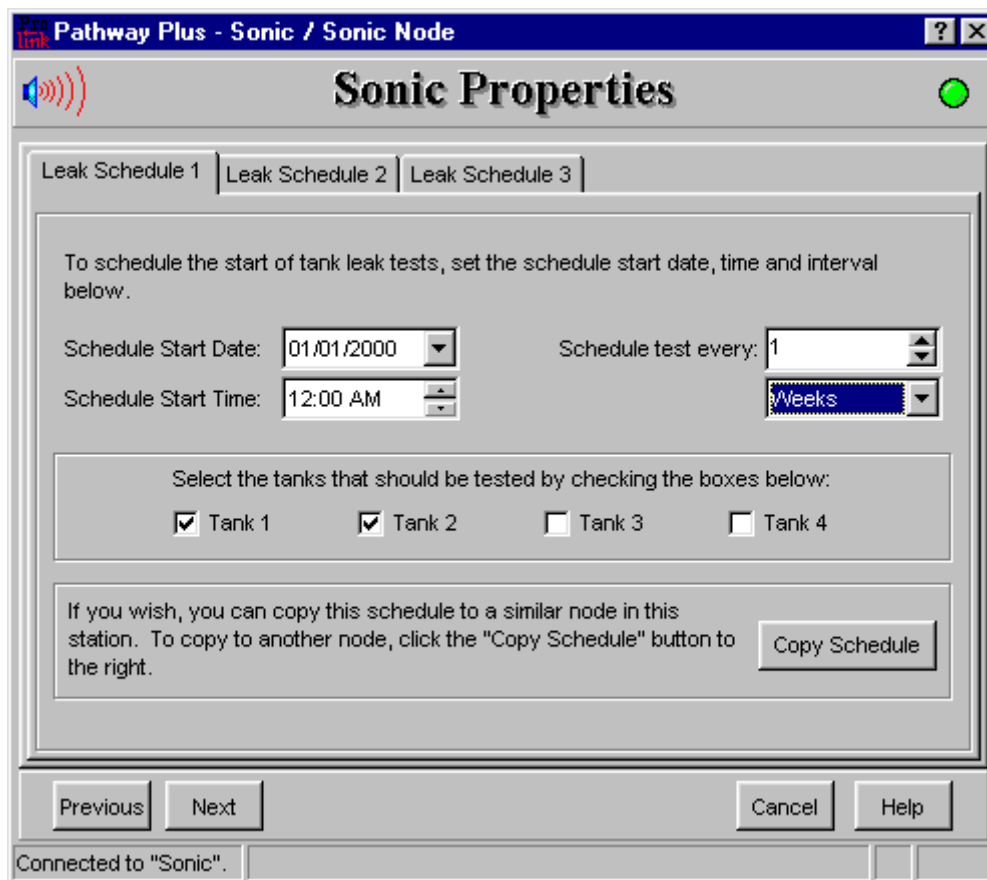

Leak Schedule #1:

Schedule Start Date: The user can set the date of when they want leak tests to begin.

Schedule Start Time: The user can set the time of when they want leak tests to begin.

The user also has the option of how often they want leak tests to be performed. You can make this decision by placing your choice in the 'schedule test every' selections boxes.

The user also has the ability to choose which tanks should be tested by checking the appropriate boxes that apply.

Copy Schedule: Allows the user to copy this schedule to a similar node in this station. To copy to another node, click on 'Copy Schedule.'

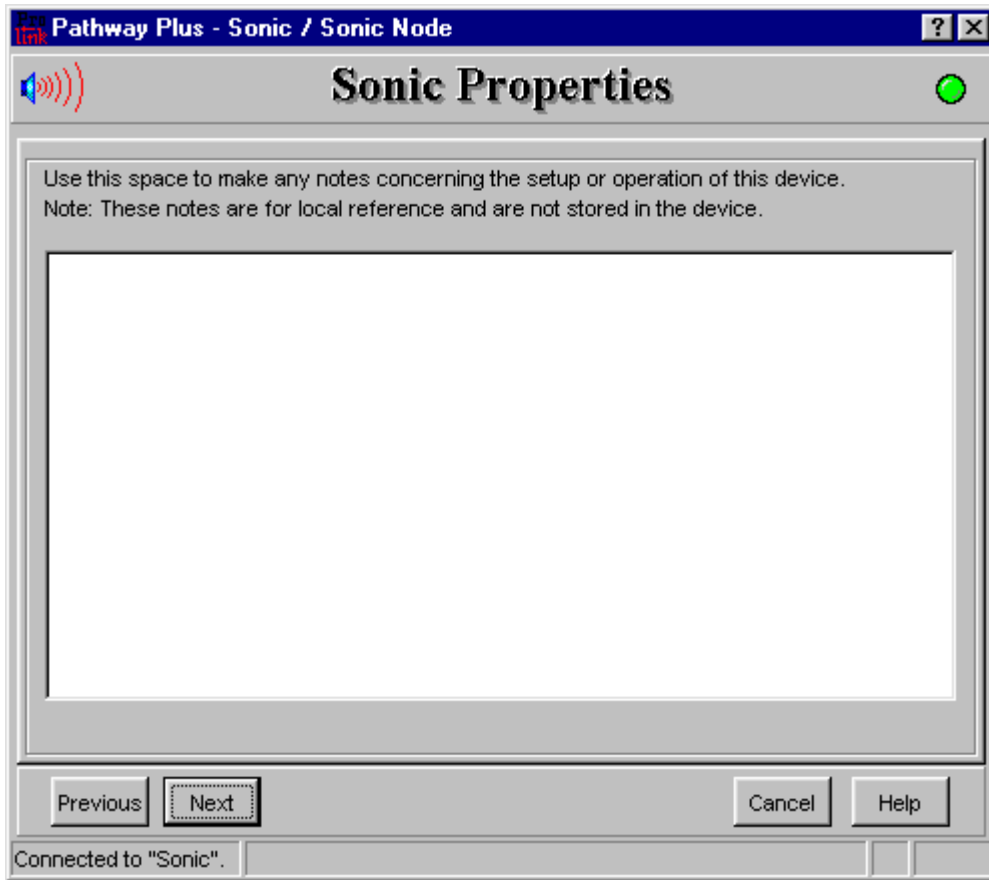

This is the user's opportunity to make any notes to have for future reference.

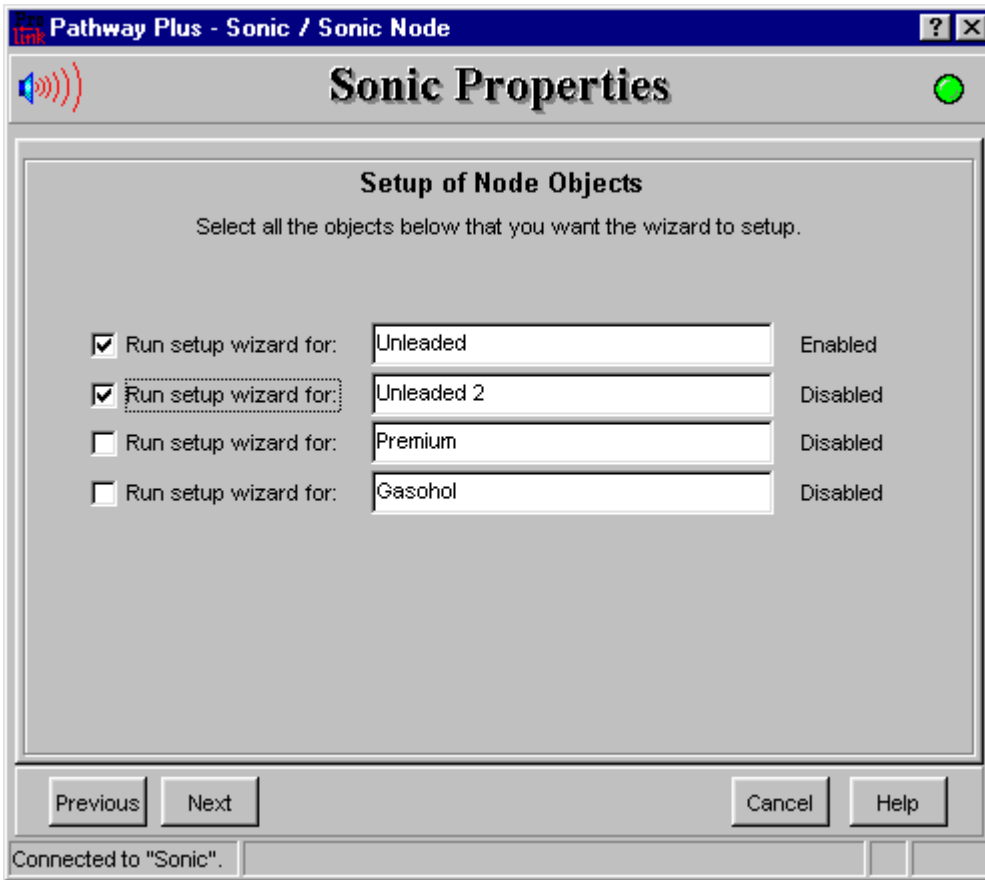

This section allows the user to select which of the Sonic tank objects that they want the Prolink Setup Wizard to configure at this time.



Setup parameters for the Sonic Node are complete! To move on select 'Next' and this will store these settings in the device.



Wink: Click on this button to blink the service LED on this node. This is helpful in situations where there is more than one network card of the same type installed in the same chassis. Blinking this LED will identify the specific card that is being configured.

The **object name** represents the current name of the device you will be working with. The **neuron id** is a permanent number, and it does not change.



Pathway Plus - Sonic / Sonic Node / Unleaded

Tank Properties

Object ID

Object Number:

Object Name

To change the object name, enter the name of the object in the box to the right:

Enabled State

To enable the object, check the box to the right: Object Enabled:

Previous Next Cancel Help

Connected to "Sonic". Idle

Object ID is uniquely identified by the specific object by number in this screen. The Object ID property indicates which object is open for configuration or setup, and is a read only field.

Object Name displays the name of the object. This field may be changed (max. 12 characters) or left at default.

Enabled State box must be 'checked' to enable operation of the corresponding tank inventory sensor.

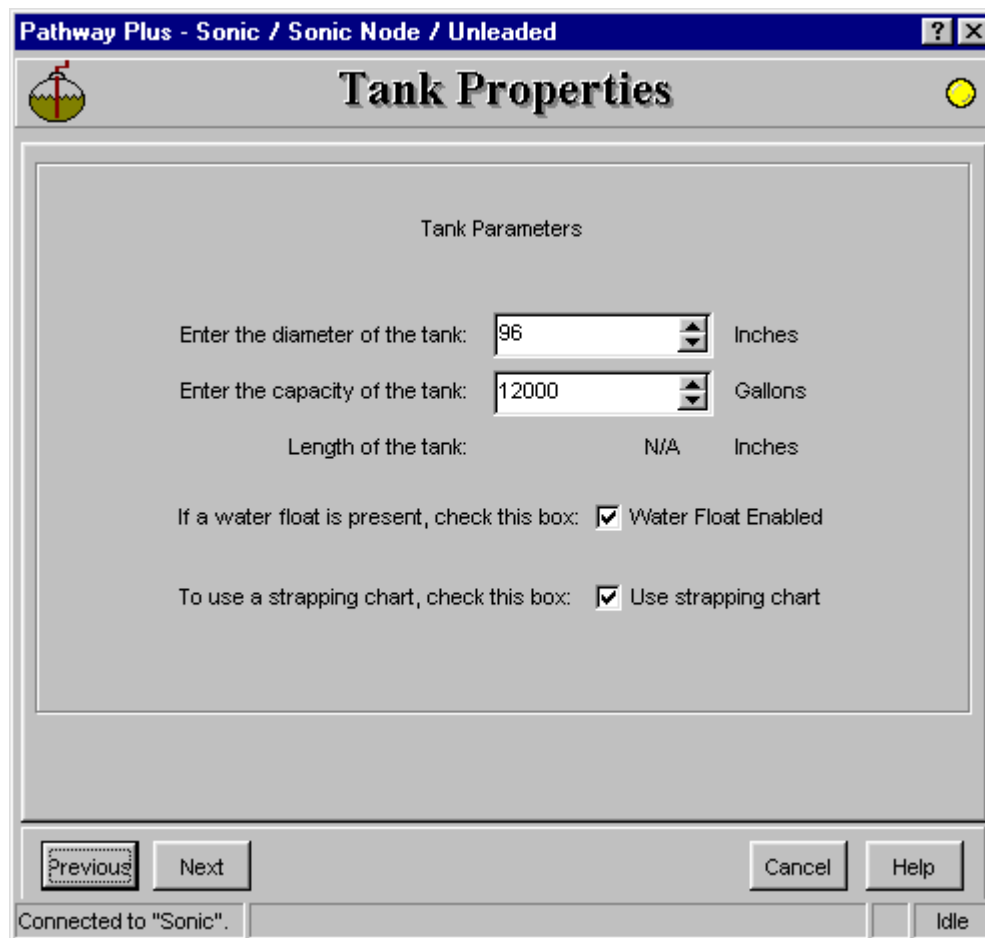

Pathway Plus - Sonic / Sonic Node / Unleaded

Tank Properties

Tank Parameters

Enter the diameter of the tank: 96 Inches

Enter the capacity of the tank: 12000 Gallons

Length of the tank: N/A Inches

If a water float is present, check this box: Water Float Enabled

To use a strapping chart, check this box: Use strapping chart

Previous Next Cancel Help

Connected to "Sonic". Idle

Tank Parameters allow the user to set up the diameter of the tank, and the tank capacity. The tank length is also displayed for reference.

Check or uncheck the 'Water Float Enabled' checkbox to indicate whether this Ultrasonic Probe does or does not have the water float installed.

If this tank is non-cylindrical, check the 'use strapping chart' checkbox to allow for data entry of the tank strapping chart in the dialog that follows.

Pathway Plus - Sonic / Sonic Node / Unleaded

Tank Properties

16 Points Height in: Inches
 32 Points Volume in: Gallons

Enter Information

Height	Volume	Height	Volume
006	0.00	054	0.00
012	0.00	060	0.00
018	0.00	066	0.00
024	0.00	072	0.00
030	0.00	078	0.00
036	0.00	084	0.00
042	0.00	090	0.00
048	0.00	096	0.00

Connected to "Sonic". Idle

For non-cylindrical tanks, use this dialog to enter in the product volume at each respective height for the tank in question.



Selections for the leak mode for the particular tank in question are selected here. For 'scheduled' mode, the tank will follow the schedule times set in the previous dialogs.

Pathway Plus - Sonic / Sonic Node / Unleaded

Tank Properties

Fuel Parameters

Select the type of fuel:

Initial Velocity:

Lt1 Coefficient:

Snd Coefficient:

Exp Coefficient:

Calibrated Temperature:

Connected to "Sonic".

Use this dialog to select the product type for this probe and tank given the pull-down list above. If the fuel type does not match any of the default types provided, select 'New Fuel Type' to create a new custom fuel type for this tank.

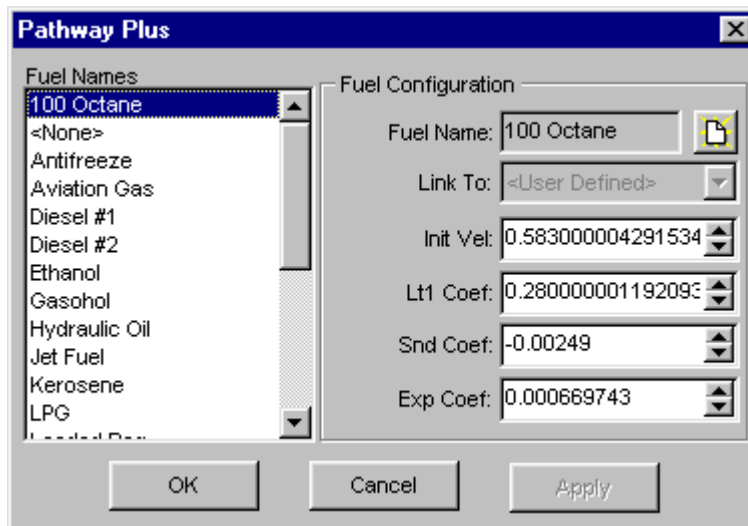

To create a custom fuel type, select the folded page button above and assign the new fuel type a custom name. In order for the new fuel type to be registered, the proper coefficients above must also be entered. Consult with Red Jacket Electronics technical support for information concerning the proper coefficients.

Pathway Plus - Sonic / Sonic Node / Unleaded

Tank Properties

Enter the alarm thresholds in the boxes below:

Min. Delivery Volume Threshold:	<input type="text" value="180"/>	Gallons
Min. Delivery Rate:	<input type="text" value="25"/>	Gallons
Delivery Wait Time:	<input type="text" value="600"/>	Seconds
Overfill Threshold:	<input type="text" value="10800"/>	Gallons
Low Product Threshold:	<input type="text" value="600"/>	Gallons
High Water Threshold:	<input type="text" value="5"/>	Inches

Previous Next Cancel Help

Connected to "Sonic". Idle

Min. Delivery Volume Threshold: Use this field to adjust the minimum volume inflow required by the card to recognize a delivery.

Min. Delivery Rate: Use this field to adjust the minimum delivery rate required on inflowing product to be recognized as a delivery.

Delivery Wait Time: This field specifies the wait time for closing and posting a delivery.

Overfill Threshold: The overfill alarm threshold can be adjusted by changing this setting (maximum setting is 95 percent of tank capacity).

Low Product Threshold: Use this field to set the alarm trigger point in volume for a low product condition.

High Water Threshold: Enter the water level threshold that will trigger a high water alarm.

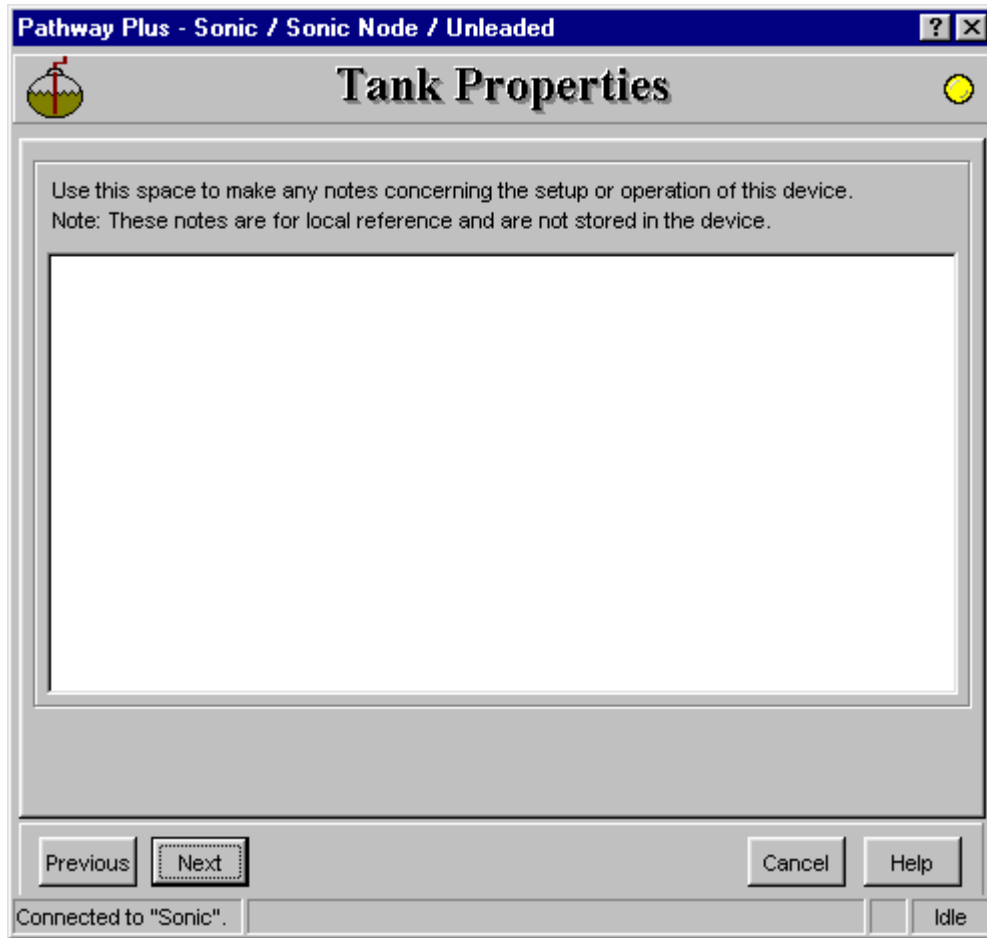

This is the user's opportunity to make any notes for future reference.



This section allows the user to select the Status Monitor. The Status Monitor is used to view the current state of the object and to verify that it is working correctly.

Pathway Plus - Gas Land #69 / Sonic #2 / Sonic Tank #01

Tank Properties

 ? X

Stop Sonic Tank #01 - Water

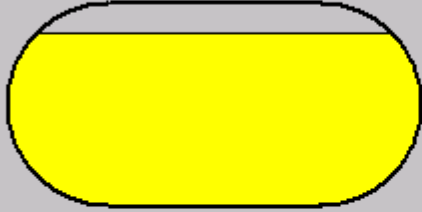

LP

HW

OV

Leak Test Passed:

Grs Vol:	12,972.6	liters	Height:	76.499	cm.
Net Vol:	12,951.5	liters	Water:	0.075	cm.
Temp:	23.1	°C	Ullage:	654.9	liters

Previous Next Cancel Help

Connected to "Gas Land #69". Idle

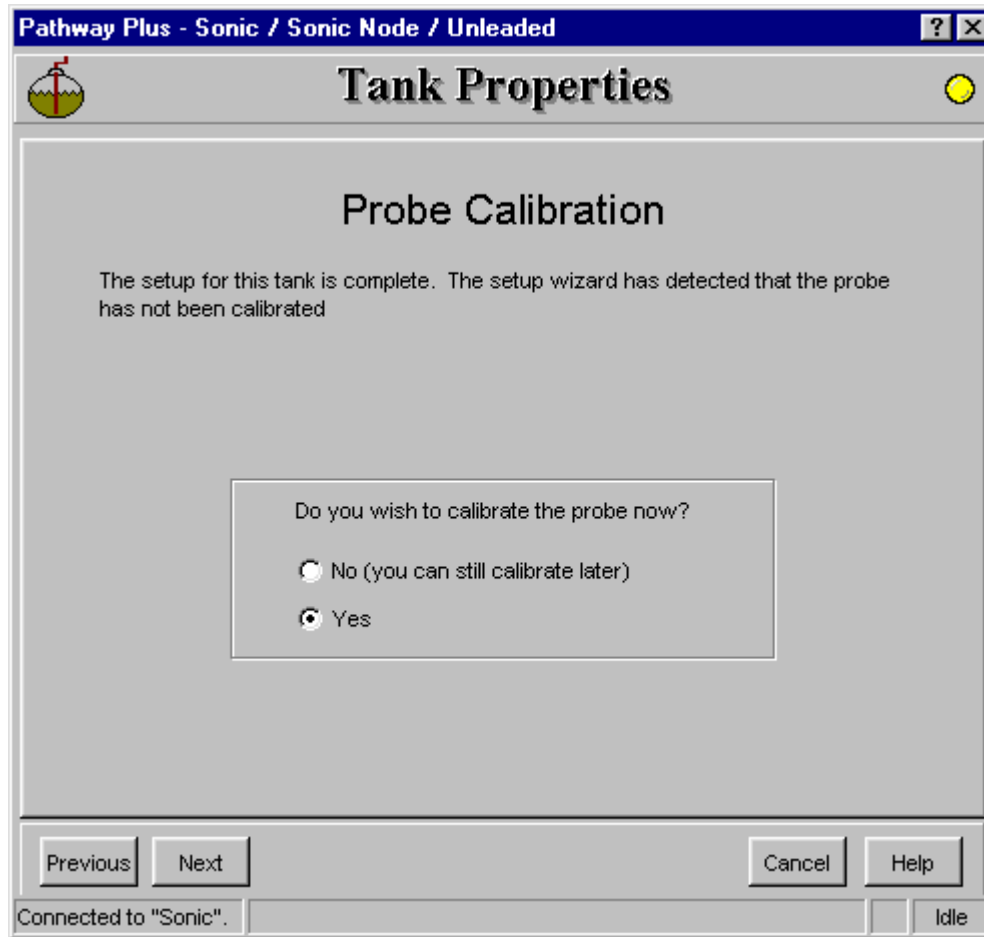

This section acknowledges that setup for the tank is complete and that the probe has not been calibrated. The user has the option to calibrate the probe at this point.

Pathway Plus - Sonic / Sonic Node / Unleaded

Tank Properties

The current calibration values are shown below. Press "Calibrate Height" to calibrate the probe to a stick reading.

Calibration Height: Inches

Transducer Top: Inches

Water Offset: Inches

Speed of sound at 20° C:

Connected to "Sonic".

Begin by selecting the 'Calibrate Height' button, and enter in a new height in the field provided. Follow up by selecting 'Calibrate top' and enter in the desired calibration height which will adjust the transducer top to the desired level. Select 'Calibrate Water' and 'Calibrate Temp.' to calibrate the water level and temperature repeatedly.



Setup is complete!

Appendix A: Replacement Parts

Part Number	Description
RJ400-685	Sonic Network Card

Ultrasonic Probe

Transceiver	Ultrasonic, sealed in proprietary epoxy
Crystal Frequency	1 MHz
Probe	316 Stainless steel
Cable	Twinaxial, Teflon jacket 100% shielded, 78 Ohm impedance
Transceiver Block	Brass (316 Stainless Steel for aviation fuels in MIL SPEC applications)

Compatible Products
100% Gasoline
100% Diesel
100% Methanol
100% Ethanol
M-85
E-85
Kerosene
Jet Fuel
Gasoline/Methanol Mixtures
Gasoline/Ethanol Mixtures
Gasoline with up to 15% MTBE
Diesel with up to 15% MTBE

Compatible Products

Special Products as Recommended by Red Jacket

To select proper sizing for the Ultrasonic probe for the straight hanger installation, refer to the section titled *Sizing Instructions for Ultrasonic probes Using a Straight Hanger* in Chapter 4 of this manual. To select proper sizing for the Ultrasonic probe for the offset hanger installation, refer to the section titled *Sizing Instructions for Ultrasonic probes Using an Offset Hanger* in Chapter 4 of this manual.

Ultrasonic Probe Sizes and Part Numbers

Part Number	Bottom of plate to bracket (cm)	Inches	Feet
RJ400-339-5	342.63	134.89	11.24
RJ400-338-5	326.23	128.44	10.70
RJ400-337-5	312.26	122.94	10.24
RE400-562-5	304.61	119.93	10.00
RJ400-319-5	295.86	116.48	9.71
RE400-561-5	288.21	113.47	9.46
RJ400-318-5	281.89	110.98	9.25
RE400-560-5	274.24	107.97	9.00
RJ400-336-5	265.49	104.52	8.71
RE400-559-5	257.84	101.51	8.46
RJ400-335-5	251.52	99.02	8.25
RE400-558-5	243.87	96.01	8.00
RJ400-334-5	235.12	92.57	7.71
RJ400-557-5	227.47	89.56	7.46
RJ400-317-5	221.15	87.07	7.26
RE400-556-5	213.50	84.06	7.00
RJ400-333-5	204.75	80.61	6.72
RJ400-555-5	197.10	77.60	6.47
RJ400-316-5	190.78	75.11	6.26
RE400-554-5	183.13	72.10	6.01
RJ400-332-5	174.38	68.65	5.72

Ultrasonic Probe Sizes and Part Numbers

Part Number	Bottom of plate to bracket (cm)	Inches	Feet
RE400-553-5	166.73	65.64	5.47
RJ400-315-5	160.41	63.15	5.26
RE400-552-5	152.76	60.14	5.01
RJ400-314-5	144.01	56.70	4.72
RE400-551-5	136.36	53.69	4.47
RJ400-331-5	130.04	51.20	4.27
RE400-550-5	122.39	48.19	4.02
RJ400-330-5	113.64	44.74	3.73
RE400-549-5	105.99	41.73	3.48
RJ400-313-5	99.67	39.24	3.27
RE400-548-5	92.02	36.23	3.02

Part Number	Description
RE400-324	CABLE, TWINAXIAL, 20 AWG., HDPE JACKET, .250" DIA, (BY THE FT.)
RE400-325	CABLE, TWINAXIAL, 20AWG., TEFLON JACKET, .125" DIA, (BY THE FT.)
RE400-644	CABLE, TWINAXIAL, 24AWG., HDPE JACKET, .180" DIA, (BY THE FT.)
RJ400-687-5	CABLE, TWINAXIAL, 24AWG., HDPE JACKET, .180" DIA, 1000' ROLL
RJ400-683-5	CABLE, TWINAXIAL, 24AWG., HDPE JACKET, .180" DIA, 1500' ROLL
RJ400-684-5	CABLE, TWINAXIAL, 24AWG., HDPE JACKET, .180" DIA, 2000' ROLL
RJ400-686-5	CABLE, TWINAXIAL, 24AWG., HDPE JACKET, .180" DIA, 2500' ROLL
RJ400-681-5	CABLE, TWINAXIAL, 24AWG., HDPE JACKET, .180" DIA, 500' ROLL
RJ400-682-5	CABLE, TWINAXIAL, 24AWG., HDPE JACKET, .180" DIA, 750' ROLL

Accessories

Part Number	Description
RJ400-305-5	12-ft.(3.65m) Coax Drop Tube (single)
RJ400-306-5	12-ft. (3.65m) Coax Drop Tube (4 pack)
RJ400-308-5	12-ft. (3.65m) Creased Drop Tube (single)
RJ400-309-5	12-ft. (3.65m) Creased Drop Tube (4 pack)
RJ400-310-5	Offset Hanger (for up to 48-in./122cm delivery risers)
RJ400-589-5	Straight Hanger (for PVC Cap)
RJ400-312	Installation Tool (for use on offset hanger install)
RJ400-380-5	Riser Pipe Extraction Tool
RJ400-585-5	Straight Hanger (for Locking Well Cap and Adapter Collar)
RJ400-538-5	Offset Hanger 6-ft./183cm (for risers over 48-in./122cm)
RJ400-620-5	Remote Audible Alarm
RJ400-379-5	Riser Pipe Adapter (3-in./7.6cm Pre-drilled for offset hanger)

Kits

Part Number	Description
RJ400-590-5	Riser Cap, 4-in. (10.1 cm) PVC
RJ340-009-5	Riser Cap, 2-in. (5cm) PVC
RJ400-322-5	Water Float Kit (included 3-in. (7.6cm) Riser Diesel Clip)
RJ400-396-5	Water Float Kit (included diesel clip)
RJ346-011-5	Locking Cap and Adapter Collar
RJ400-307-5	Straight Hanger for the 3-in.(7.6cm) PVC Well Cap
RJ400-592-5	Straight Hanger with 4-in. (10.1 cm) PVC Well Cap
RJ400-593-5	Straight Hanger with 4-in. (10.1 cm) Locking Well Cap and Adapter Collar

Ultrasonic Probe Parts

Part Number	Description
RE400-397-5	Diesel Clip
RE400-394-5	Transceiver (for use with ultrasonic probe up to 8-ft.(2.44m) in length)
RJ400-444-5	Transceiver (for use with ultrasonic probe over 8-ft. (2.44m) in length) 20ft. cable

Index

C

Caution, definition of	viii
Conduit Installation	3-1
Connections, Ultrasonic probe to the Sonic network card	5-3

D

DANGER, definition of	viii
Direct Bury Cable Installation	3-3

I

Information, intrinsic safety	1-1
Installation DOs and DON'Ts	1-2
Installation Requirements, Sonic network card ..	2-1
Introduction, Sonic network card	2-1

N

Notice, definition of	viii
-----------------------------	------

P

Precautions, intrinsic safety	1-1
Prolink Configuration Worksheet SAMPLE, ultrasonic probe	4-2
Prolink Programming Configuration Worksheet, information	2-2

R

Requirements, installation, sonic network card ..	2-1
---	-----

S

SAMPLE, Prolink Configuration Worksheet ..	2-2
--	-----

Sizing Instructions, Ultrasonic probe using a straight hanger	4-3
Sonic network card, installation in the Prolink chassis	5-1

T

Terminology	viii
-------------------	------

U

Ultrasonic probe installation, methods	4-1
Ultrasonic probe, installing in a dedicated riser ..	4-3
Ultrasonic probes, sizing instructions using a straight hanger	4-3

W

WARNING, definition of	viii
------------------------------	------