



AtlasX Fuel Systems

---

# Owner's Manual

## Computer Programs and Documentation

All Gasboy computer programs (including software on diskettes and within memory chips) and documentation are copyrighted by, and shall remain the property of, Gasboy. Such computer programs and documents may also contain trade secret information. The duplication, disclosure, modification, or unauthorized use of computer programs or documentation is strictly prohibited, unless otherwise licensed by Gasboy.

## Approvals

**Gasboy, Greensboro, is an ISO 9001:2000 registered facility.  
Underwriters Laboratories (UL):**

UL File#	Products listed with UL
MH66256	All AtlasX dispensers and self-contained pumping units.

## Trademarks

### Non-registered trademarks

AtlasX™  
Ultra-Hi™  
GOLD<sup>SM</sup>

### Registered trademarks

Gasboy®  
Gilbarco®

Additional US and foreign trademarks pending.

Other brand or product names shown may be trademarks or registered trademarks of their respective holders.

7300 W. Friendly Ave.  
Greensboro, NC  
27410, USA

<https://www.gasboy.com/us/content/contact-us-gasboy>

## Federal Communications Commission (FCC) Compliance Statement

This device complies with Part 15 of the FCC Rules. Operation is subject to the following two conditions:

- (1) This device may not cause harmful interference, and
- (2) this device must accept any interference received, including interference that may cause undesired operation.

## FCC Warning

This equipment has been tested and found to comply with the limits for a Class A digital device pursuant to Part 15 of the FCC Rules. These limits are designed to provide reasonable protection against harmful interference when the equipment is operated in a commercial environment. This equipment generates, uses, and can radiate radio frequency energy, and if not installed and used in accordance with the instruction manual, may cause harmful interference to radio communications. Operation of this equipment in a residential area is likely to cause harmful interference in which case the user will be required to correct the interference at his own expense. Changes or modifications not expressly approved by the manufacturer could void the user's authority to operate this equipment.



# Table of Contents

<b>1 – Introduction</b>	<b>1-1</b>
Purpose . . . . .	1-1
Intended Users . . . . .	1-1
Scope . . . . .	1-1
Abbreviations and Acronyms . . . . .	1-2
<b>2 – Important Safety Information</b>	<b>2-1</b>
<b>3 – The AtlasX Fuel System</b>	<b>3-1</b>
Pump/Dispenser Components . . . . .	3-1
Model Information . . . . .	3-1
Electronic Commercial High Flow Pumps and Dispensers . . . . .	3-1
Mechanical Commercial Pump/Dispenser . . . . .	3-3
Electronic Retail Pump/Dispenser . . . . .	3-4
Electronic Series Highlights . . . . .	3-4
Mechanical Series Highlights . . . . .	3-5
Common Functions . . . . .	3-5
Understanding Date Codes . . . . .	3-6
Pump Totals (9100 Series) . . . . .	3-7
Electronic Totals (8800/9800) . . . . .	3-7
Site Preparation . . . . .	3-8
Important Considerations for DEF Dispensers . . . . .	3-8
Guidelines in AtlasX Fuel Systems Documentation and Other Codes . . . . .	3-9
General Guidelines . . . . .	3-9
Hoses . . . . .	3-10
Determining Hose Length . . . . .	3-10
Install Warning Labels and Signs for Customers . . . . .	3-10
Operating Pumps/Dispensers . . . . .	3-11
Opening the Bezel Assembly . . . . .	3-11
Opening the Lower Panel Assembly . . . . .	3-13
Reassembling the Lower Panel . . . . .	3-14
Electronic Component Access . . . . .	3-16
Programming 8800/9800 Models . . . . .	3-16
Programming the 8800/9800 Series Electronic Units . . . . .	3-16
Level 1 Programming and Data Access . . . . .	3-16
Manager Keypad Key Definitions and Use . . . . .	3-17
Programming Steps . . . . .	3-17
Security/PIN Code Entry . . . . .	3-17
Programming Quick Reference: AtlasX . . . . .	3-17
Command Code 19: Set AtlasX Related Options . . . . .	3-20
Command Code 20: Set PPU Values . . . . .	3-21
Command Code 24: Set Operations Mode . . . . .	3-21
Level 2 Programming . . . . .	3-21
Level 3 Programming . . . . .	3-21
Level 4 Programming . . . . .	3-22
AtlasX Error Codes . . . . .	3-23
ATC Programming . . . . .	3-24
ATC Review Mode . . . . .	3-25

## Table of Contents

---

Real-time Data Review - ATC	3-25
ATC Specific Error Codes	3-26
Displaying Pump Totals	3-27
Shear Valve	3-27
Operating Sequence for Series 9100 Only	3-30
Pump	3-30
Remote Dispenser	3-30
Operating Sequence for Electronic Series	3-31
Self-Contained Pumping Unit	3-31
Dispenser Units - Fueling Unit with No Motor and Pump in the Bottom	3-31
Error Codes	3-32
Electronic Calibration	3-35
Start-up and Test Section for Electronic Series	3-38
Installation Completion Checklist	3-38
Start-up	3-39
POST Start-up Tests	3-39
Voltage	3-39
Tightness	3-39
Belts (Suction Pumps Only)	3-39
Safety Information	3-40
Preparing for Servicing the Pumps/Dispensers	3-40
Call Gasboy First	3-40
Service Preparation	3-41
Before Calling for Service	3-41
Description of Problem	3-41
Warranty Service	3-41
Replacement Parts	3-41
Specialized Training	3-42
Preventive Maintenance	3-42
Maintenance of Vendor Supplied Parts	3-43
Use Authorized Parts	3-43
Performing Inspections	3-43
Safety Warnings	3-44
General Inspections	3-44
Component Inspections	3-45
Power Reset External Adjustment (Mechanical Units)	3-45
Filter Strainer Replacement	3-46
Special Setup Required for Aircraft Fueling	3-47
Adjusting the Belts (Suction Pumps Only)	3-47
Preserve the Finish of Your Pumps	3-47

## Glossary

G-1

---

A	G-1
Authorized Service Contractor (ASC)	G-1
B	G-1
Breakaway	G-1
C	G-1
Couplings	G-1
Cradle	G-1
D	G-1
DEF	G-1
Dispenser	G-2
Drive Offs	G-2

---

E	.....	G-2
E85	.....	G-2
G	.....	G-2
Grade	.....	G-2
Graphite Lubricant	.....	G-2
H	.....	G-2
Hose Retriever	.....	G-2
Hydraulic Connections	.....	G-2
I	.....	G-2
J	.....	G-3
L	.....	G-3
M	.....	G-3
Mode of Operation	.....	G-3
N	.....	G-3
Nozzle	.....	G-3
Nozzle Hook	.....	G-3
O	.....	G-3
P	.....	G-3
Pump	.....	G-3
Pump Pulleys	.....	G-4
S	.....	G-4
Shear Valves	.....	G-4
Side A	.....	G-4
Side B	.....	G-4
Silicone Grease	.....	G-4
Standalone Mode	.....	G-4
Submersible Turbine Pump (STP)	.....	G-4
Swivels	.....	G-4
V	.....	G-4

*This page is intentionally left blank.*

# 1 – Introduction

---

## Purpose

This manual provides instructions for safely operating, programming, and maintaining the AtlasX Fuel Systems pumps/dispensers.

### CAUTION

Certain special alternative fuels such as E85 and additives can degrade pump/dispenser performance or integrity if the dispensers are not designed for use with such fuels. Additionally, converting to certain standard fuels (gasoline, diesel, kerosene, and so on) from alternative fuels such as those with ethanol (E85), methanol, or Biodiesel or from alternative fuels to standard fuels can degrade dispenser performance or integrity. Similar effects can also occur when converting units to different standard fuel types. **As per Underwriters Laboratory (UL®) 87A requirements, nozzles dispensing E85 fuel and Diesel Exhaust Fluid (DEF) must not be used to dispense any other type of fuel such as Gasoline.**

Leaks and potential environmental hazards can result or components may fail prematurely.

To avoid these issues, follow the guidelines provided for dispensing E85 fuel and DEF in this manual and *MDE-5692 AtlasX Fuel Systems Installation Manual*.

## Intended Users

This manual is written for the owners and the operators of the AtlasX Fuel Systems pumps and dispensers.

## Scope

This manual provides the following information about the AtlasX Fuel Systems pumps and dispensers:

- Operating the pumps/dispensers
- Preparing the pumps/dispensers for service
- Maintaining the pumps/dispensers

# Abbreviations and Acronyms

The following table contains a list of abbreviations and acronyms used in this manual.

*Note: For more detailed definitions, refer to “Glossary” on page G-1.*

<b>Term</b>	<b>Description</b>
ASC	Authorized Service Contractor
ATC	Automatic Temperature Compensation
CC	Command Code
CFR	Code of Federal Regulations
CPU	Central Processing Unit
DEF	Diesel Exhaust Fluid
E-CAL	Electronic Calibration
EC	Error Code
FCC	Federal Communications Commission
GPM	Gallons Per Minute
HF	High Flow
LCD	Liquid Crystal Display
LPM	Liters Per Minute
LSD	Least Significant Digits
MSD	Most Significant Digit
NEC®	National Electric Code
NFPA®	National Fire Protection Association
OSHA	Occupational Safety and Health Association
PCB	Printed Circuit Board
POS	Point of Sale
PPG	Price Per Gallon
PPL	Price Per Liter
PPU	Price Per Unit
RAM	Random Access Memory
ROM	Read-Only Memory
SF	Standard Flow
STP	Submersible Turbine Pump
UHF	Ultra High Flow
UL	Underwriters Laboratory

## 2 – Important Safety Information

**Notes: 1) Save this Important Safety Information section in a readily accessible location.**

**2) Although DEF is non-flammable, diesel is flammable. Therefore, for DEF cabinets that are attached to diesel dispensers, follow all the notes in this section that pertain to flammable fuels.**

This section introduces the hazards and safety precautions associated with installing, inspecting, maintaining or servicing this product. Before performing any task on this product, read this safety information and the applicable sections in this manual, where additional hazards and safety precautions for your task will be found. Fire, explosion, electrical shock or pressure release could occur and cause death or serious injury, if these safe service procedures are not followed.



### Preliminary Precautions

You are working in a potentially dangerous environment of flammable fuels, vapors, and high voltage or pressures. Only trained or authorized individuals knowledgeable in the related procedures should install, inspect, maintain or service this equipment.

### Emergency Total Electrical Shut-Off

The first and most important information you must know is how to stop all fuel flow to the pump/dispenser and island. Locate the switch or circuit breakers that shut off all power to all fueling equipment, dispensing devices, and Submerged Turbine Pumps (STPs).

**⚠ WARNING**

The EMERGENCY STOP, ALL STOP, and PUMP STOP buttons at the cashier's station WILL NOT shut off electrical power to the pump/dispenser. This means that even if you activate these stops, fuel may continue to flow uncontrolled.

You must use the TOTAL ELECTRICAL SHUT-OFF in the case of an emergency and not the console's ALL STOP and PUMP STOP or similar keys.

### Total Electrical Shut-Off Before Access

Any procedure that requires access to electrical components or the electronics of the dispenser requires total electrical shut off of that unit. Understand the function and location of this switch or circuit breaker before inspecting, installing, maintaining, or servicing Gasboy equipment.

### Evacuating, Barricading and Shutting Off

Any procedure that requires access to the pump/dispenser or STPs requires the following actions:



- An evacuation of all unauthorized persons and vehicles from the work area
- Use of safety tape, cones or barricades at the affected unit(s)
- A total electrical shut-off of the affected unit(s)

### Read the Manual

Read, understand and follow this manual and any other labels or related materials supplied with this equipment. If you do not understand a procedure, call a Gasboy Authorized Service Contractor or call the Gasboy Support Center at 1-800-444-5529. It is imperative to your safety and the safety of others to understand the procedures before beginning work.

### Follow the Regulations

Applicable information is available in National Fire Protection Association (NFPA) 30A; *Code for Motor Fuel Dispensing Facilities and Repair Garages*, NFPA 70; *National Electrical Code (NEC)*, Occupational Safety and Health Administration (OSHA) regulations and federal, state, and local codes. All these regulations must be followed. Failure to install, inspect, maintain or service this equipment in accordance with these codes, regulations and standards may lead to legal citations with penalties or affect the safe use and operation of the equipment.

### Replacement Parts

Use only genuine Gasboy replacement parts and retrofit kits on your pump/dispenser. Using parts other than genuine Gasboy replacement parts could create a safety hazard and violate local regulations.

### Safety Symbols and Warning Words

This section provides important information about warning symbols and boxes.

#### Alert Symbol

 This safety alert symbol is used in this manual and on warning labels to alert you to a precaution which must be followed to prevent potential personal safety hazards. Obey safety directives that follow this symbol to avoid possible injury or death.

#### Signal Words

These signal words used in this manual and on warning labels tell you the seriousness of particular safety hazards. The precautions below must be followed to prevent death, injury or damage to the equipment:

 **DANGER:** Alerts you to a hazard or unsafe practice which will result in death or serious injury.

 **WARNING:** Alerts you to a hazard or unsafe practice that could result in death or serious injury.

 **CAUTION with Alert symbol:** Designates a hazard or unsafe practice which may result in minor injury.

**CAUTION without Alert symbol:** Designates a hazard or unsafe practice which may result in property or equipment damage.

### Working With Fuels and Electrical Energy

#### Prevent Explosions and Fires

Fuels and their vapors will explode or burn, if ignited. Spilled or leaking fuels cause vapors. Even filling customer tanks will cause potentially dangerous vapors in the vicinity of the dispenser or island.

DEF is non-flammable. Therefore, explosion and fire safety warnings do not apply to DEF fluid lines. No Open Fire

## Important Safety Information



Open flames from matches, lighters, welding torches or other sources can ignite fuels and their vapors.

### No Sparks - No Smoking



Sparks from starting vehicles, starting or using power tools, burning cigarettes, cigars or pipes can also ignite fuels and their vapors. Static electricity, including an electrostatic charge on your body, can cause a spark sufficient to ignite fuel vapors. Every time you get out of a vehicle, touch the metal of your vehicle, to discharge any electrostatic charge before you approach the dispenser island.

### Working Alone

It is highly recommended that someone who is capable of rendering first aid be present during servicing. Familiarize yourself with Cardiopulmonary Resuscitation (CPR) methods, if you work with or around high voltages. This information is available from the American Red Cross. Always advise the station personnel about where you will be working, and caution them not to activate power while you are working on the equipment. Use the OSHA Lockout/Tagout procedures. If you are not familiar with this requirement, refer to this information in the service manual and OSHA documentation.

### Working With Electricity Safely

Ensure that you use safe and established practices in working with electrical devices. Poorly wired devices may cause a fire, explosion or electrical shock. Ensure that grounding connections are properly made. Take care that sealing devices and compounds are in place. Ensure that you do not pinch wires when replacing covers. Follow OSHA Lockout/Tagout requirements. Station employees and service contractors need to understand and comply with this program completely to ensure safety while the equipment is down.

### Hazardous Materials

Some materials present inside electronic enclosures may present a health hazard if not handled correctly. Ensure that you clean hands after handling equipment. Do not place any equipment in the mouth

#### WARNING

The pump/dispenser contains a chemical known to the State of California to cause cancer.

#### WARNING

The pump/dispenser contains a chemical known to the State of California to cause birth defects or other reproductive harm.



Gilbarco Veeder-Root encourages the recycling of our products. Some products contain electronics, batteries, or other materials that may require special management practices depending on your location. Please refer to your local, state, or country regulations for these requirements.

## In an Emergency

### Inform Emergency Personnel

Compile the following information and inform emergency personnel:

- Location of accident (for example, address, front/back of building, and so on)
- Nature of accident (for example, possible heart attack, run over by car, burns, and so on)
- Age of victim (for example, baby, teenager, middle-age, elderly)
- Whether or not victim has received first aid (for example, stopped bleeding by pressure, and so on)
- Whether or not a victim has vomited (for example, if swallowed or inhaled something, and so on)

#### WARNING



Gasoline/DEF ingested may cause unconsciousness and burns to internal organs. Do not induce vomiting. Keep airway open. Oxygen may be needed at scene. Seek medical advice immediately.

#### WARNING

DEF generates ammonia gas at higher temperatures. When opening enclosed panels, allow the unit to air out to avoid breathing vapors. If respiratory difficulties develop, move victim away from source of exposure and into fresh air. If symptoms persist, seek medical attention.

#### WARNING



Gasoline inhaled may cause unconsciousness and burns to lips, mouth and lungs. Keep airway open. Seek medical advice immediately.

#### WARNING



Gasoline/DEF spilled in eyes may cause burns to eye tissue. Irrigate eyes with water for approximately 15 minutes. Seek medical advice immediately.

#### WARNING



Gasoline/DEF spilled on skin may cause burns. Wash area thoroughly with clear water. Seek medical advice immediately.

#### WARNING



DEF is mildly corrosive. Avoid contact with eyes, skin, and clothing. Ensure that eyewash stations and safety showers are close to the work location. Seek medical advice/recommended treatment if DEF spills into eyes.

**IMPORTANT:** Oxygen may be needed at scene if gasoline has been ingested or inhaled. Seek medical advice immediately.

### Lockout/Tagout

Lockout/Tagout covers servicing and maintenance of machines and equipment in which the unexpected energization or start-up of the machine(s) or equipment or release of stored energy could cause injury to employees or personnel. Lockout/Tagout applies to all mechanical, hydraulic, chemical, or other energy, but does not cover electrical hazards. Subpart S of 29 CFR Part 1910 - Electrical Hazards, 29 CFR Part 1910.333 contains specific Lockout/Tagout provision for electrical hazards.

## Hazards and Actions

 <b>WARNING</b>	
	Spilled fuels, accidents involving pumps/dispensers, or uncontrolled fuel flow create a serious hazard.
	Fire or explosion may result, causing serious injury or death.
Follow established emergency procedures. DEF is non-flammable. However it can create a slip hazard. Clean up spills promptly.	

The following actions are recommended regarding these hazards:

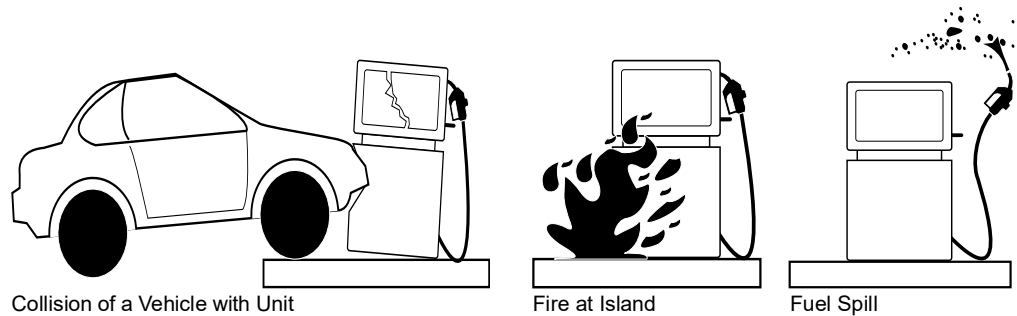

- Do not go near a fuel spill or allow anyone else in the area.
- Use station EMERGENCY CUTOFF immediately. Turn off all system circuit breakers to the island(s).
- Do not use console E-STOP, ALL STOP, and PUMP STOP to shut off power. These keys do not remove AC power and do not always stop product flow.
- Take precautions to avoid igniting fuel. Do not allow starting of vehicles in the area. Do not allow open flames, smoking or power tools in the area.
- Do not expose yourself to hazardous conditions such as fire, spilled fuel or exposed wiring.
- Call emergency numbers.

*This page is intentionally left blank.*

## 3 – The AtlasX Fuel System

### Pump/Dispenser Components

This section provides figures that show the internal and external components of pumps and provides information about these components. Refer to this section as you perform the procedures in this manual.

### Model Information

#### Electronic Commercial High Flow Pumps and Dispensers

The external components of a Gasboy pump/dispenser (Electronic Commercial) are shown in [Figure 3-1](#).

**Figure 3-1: Electronic Commercial Unit**

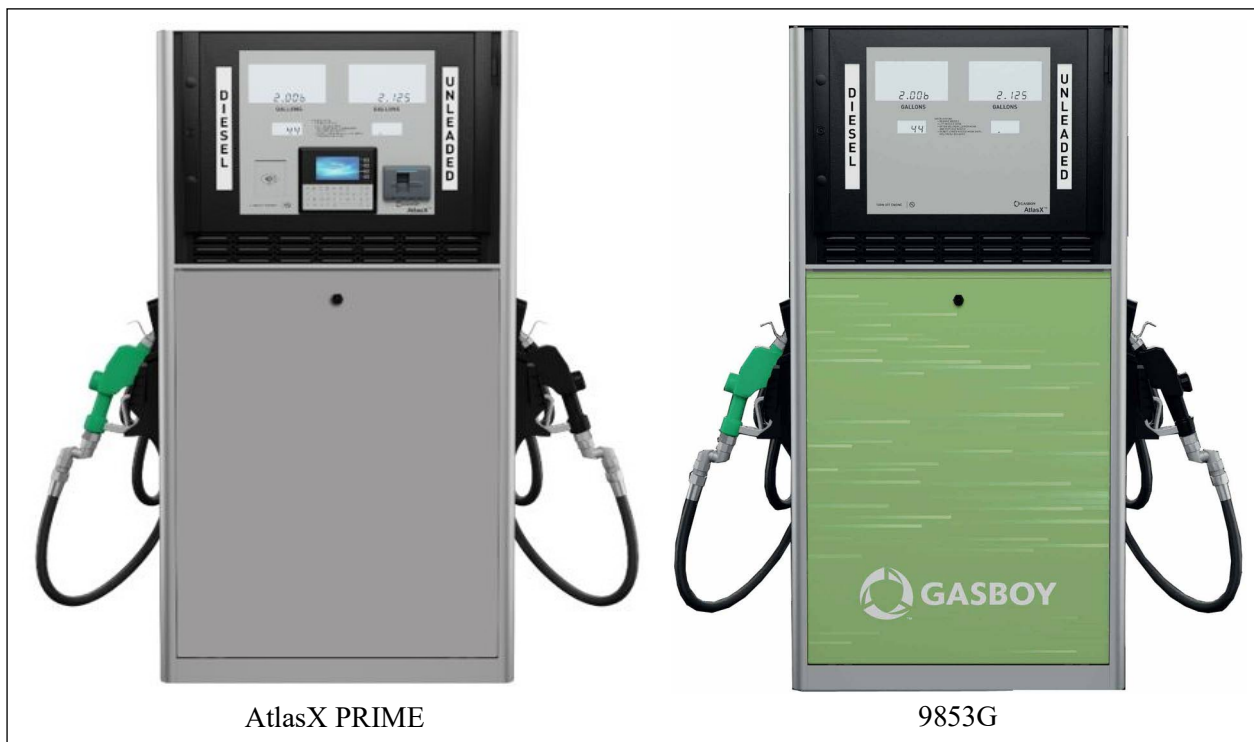
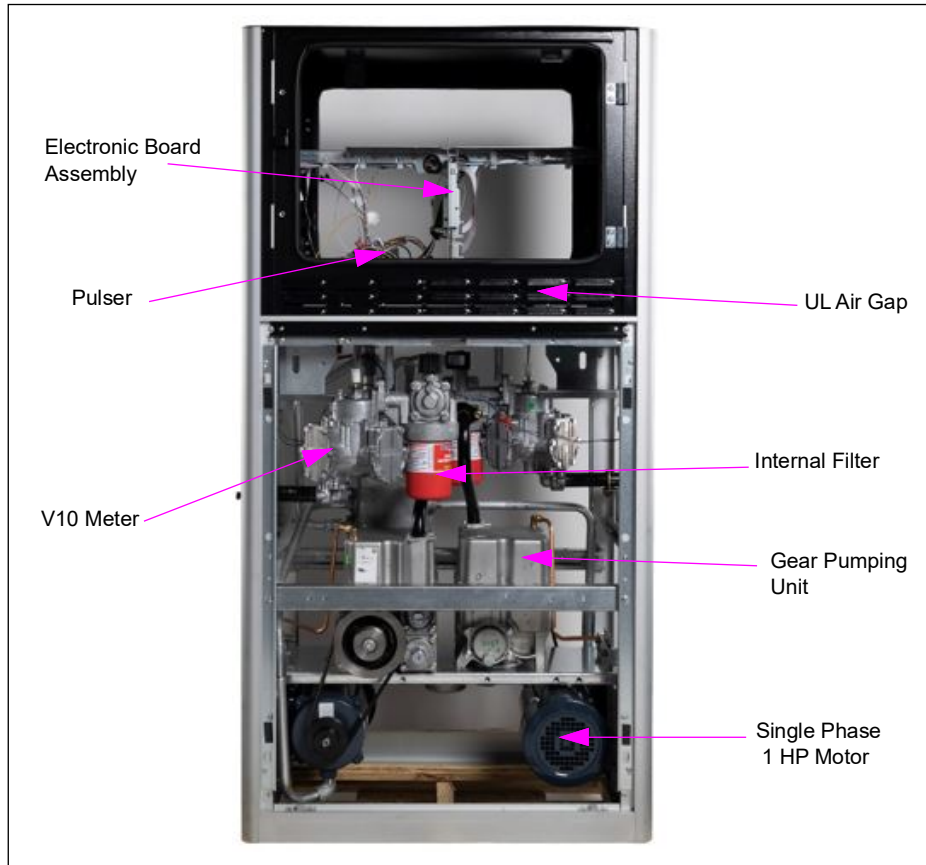

Figure 3-2: Internal Components



## Mechanical Commercial Pump/Dispenser

The external components of a Gasboy pump/dispenser (Mechanical unit) are shown in [Figure 3-3](#). Mechanical units have mechanical type displays as opposed to electronic digital type displays.

**Figure 3-3: AtlasX Mechanical Commercial Unit**



## Electronic Retail Pump/Dispenser

The external components of a Gasboy pump/dispenser (Electronic Retail unit) are shown in [Figure 3-4](#). Electronic units have digital displays as opposed to mechanical displays. In units that are Electronic Commercial instead of Retail, the external components are the same, except that they do not have a Monetary Sale amount, a PPU display, or Monetary Totalizer display.

**Figure 3-4: AtlasX Electronic Retail Unit**



## Electronic Series Highlights

The Gasboy AtlasX dispensing units are UL-listed and are available in a self-contained (suction pump) package or in a remote-controlled (dispenser) package. Both packages offer varieties of models which are available as single hose outlets or dual hose outlets (with single or dual product capability). The following models are available:

- High Flow (HF) models up to 22 GPM, 83 LPM, and 18 IPM

The rate of delivery for the remote-controlled packages will vary according to the size of the submersible pump. The delivery rate of both packages will also vary depending on the installation conditions and added accessories.

Visual identification can be quickly made between Commercial and Retail pumps/dispensers. Commercial pumps/dispensers have displays only for gallons/liters on a side(s), when Retail has displays for both gallons/liters, dollar total, and cost per gallon/liter.

## Mechanical Series Highlights

The Gasboy Series 9100G dispensing units are UL-listed and are available in a self-contained (suction pump) package or in a remote-controlled (dispenser) package. Both packages offer varieties of models which are available as single hose outlets or dual hose outlets (with single or dual product capability). The self-contained models are available in high speed, up to 83 LPM/22 GPM. The rate of delivery for the remote-controlled packages will vary according to the size of the submersible pump. The delivery rate of both packages will also vary depending on the installation conditions and added accessories.

All models of the Series 9100G offer mechanical non-computers complete with electric resets.

Mechanical pump registers show the total volume for a delivery. All non-computers will read up to 999.9 gallons or liters.

The AtlasX electronic units can either have Side Load or Front Load nozzle configuration. Mechanical units are side-load only. The AtlasX pump/dispenser offers the following features.

Models	Suction Pumps	Remote Dispensers	Features
HF Mechanical Commercial	9153G, 9153GTW1M, 9153GTW2	9153GX, 9153GXTW1, 9153GXTW2	<ul style="list-style-type: none"> <li>• Inlet: 1-1/2" NPT female threads</li> <li>• Discharge: 1" NPT female threads</li> <li>• Motor: (self-contained) 1 HP continuous duty</li> </ul>
HF Electronic Commercial	9853G, 9853GTW1M, 9853GTW2	9853GX, 9853GXTW1, 9853GXTW2	
HF Electronic Retail	8853G, 8853GTW1M, 8853GTW2	8853GX, 8853GXTW1, 8853GXTW2	
UHF Electronic Commercial	-	9850GX, 9850GXTW1, 9850GXTW2, 9850GXTW3	<ul style="list-style-type: none"> <li>• Inlet: 2" NPT female threads</li> <li>• Discharge: 1" NPT female threads</li> </ul>
UHF Electronic Retail	-	8850GX, 8850GXTW1, 8850GXTW2, 8850GXTW3	<ul style="list-style-type: none"> <li>• Inlet: 2" NPT female thread</li> <li>• Discharge: 1" NPT female threads</li> </ul>
DEF Dispenser Commercial	-	9862GX-Z, 9862GX-ZWW, 9862GX-WWW	<ul style="list-style-type: none"> <li>• Bottom Inlet: 1" BSPP female threads</li> <li>• Side Inlet: 1" BSPP male threads</li> <li>• Discharge: 1" BSPP male threads</li> </ul>
DEF Dispenser Retail	-	8862GX-Z, 8862GX-ZWW, 8862GX-WWW	

## Common Functions

This subsection provides instructions for common functions on the Gasboy AtlasX pumps/dispensers.

## Understanding Date Codes

A two letter date code is stamped on the serial number plate before the serial number. This code shows the month and year of manufacture. To determine the age of the equipment for warranty purposes, refer to the date code.

**Figure 3-5: Serial Number Plate**

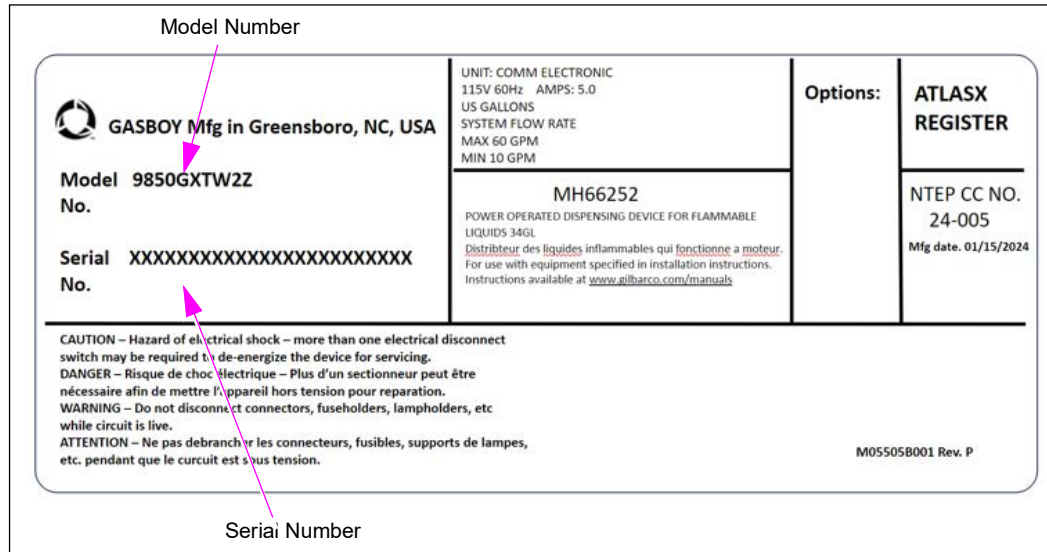

For example, a serial number plate stamped “BP AT000199” contains the following information:

- Date code [BP]—This unit was manufactured in B=February P=2005.
- Serial Number [AT000199]

To determine the date code on a Gasboy pump/dispenser, refer to the following tables.

Month Codes		
A = January	E = May	J = September
B = February	F = June	K = October
C = March	G = July	L = November
D = April	H = August	M = December

Year Codes		
P = 2005	A = 2012	L = 2022
R = 2006	B = 2013	M = 2023
S = 2007	C = 2014	N = 2024
T = 2008	D = 2015	P = 2025
U = 2009	E = 2016	R = 2026
V = 2010	F = 2017	S = 2027
X = 2011	G = 2018	T = 2028
	H = 2019	U = 2029
	J = 2020	W = 2030
	K = 2021	X = 2031

## Pump Totals (9100 Series)

Pump totals can be read from the totalizers. At the close of each day's business, the total can be read from the unit and subtracted from the day before to obtain the total for that day. If the unit is in use 24 hours a day, it is advisable to take the readings in the morning also, so as to monitor the night usage.

Figure 3-6: Pump Totals - 9100

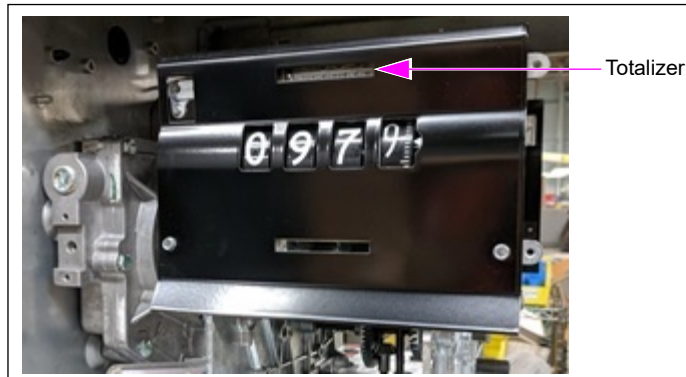

## Electronic Totals (8800/9800)

The AtlasX stores a running quantity total for each pump side. These electronic totalizers work independent of the optional electrical mechanical totalizers that may be installed and are shown as gallons (liters) on the displays (Totals will be display in both the volume and PPU area of the display). The totalizer data is stored in battery-backed memory. The AtlasX is supplied with a manager's keypad which allows you to view the electronic totalizers.

To view pump totalizers, ensure that the pump handles are off; and no transaction is in progress. Open the bezel door and locate the manager's keypad. Connect the keypad to P6405 on the A side active display. Press **VOL TOTAL** on the keypad. The totalizer data for side 1 will be displayed. To view the totals for side 2, press the **2** on the keypad. To clear the display, press the **CLEAR**. These totals cannot be reset.

## Site Preparation

To ensure safety and long-term reliability of your equipment, ensure that your units are installed by a knowledgeable Authorized Service Contractor (ASC). When your units are installed, ensure that the installer considers the guidelines in the following section.

### Important Considerations for DEF Dispensers

#### CAUTION

Applicable during Installation and Operation of the Dispenser: DEF freezes at approximately 11 °F (-11.5 °C). Power to the dispenser and heater must always remain ON in cold weather. If power is lost and the temperature drops below this point within the DEF cabinet, the system must be inspected for freeze damage before restart. For sites that experience occasional power losses or for sites that are located in very cold climates, it is recommended that a backup power generator be used to maintain constant power to the dispenser. Do not use any additives to lower the freezing point of DEF. Additives of any type must not be used in DEF. Freezing can result in damage or inoperative hose breakaways, fluid lines or components, valves, nozzles and meters.

Prolonged storage at temperatures above 77 °F (25 °C) can impair the quality of DEF and reduce its shelf life.

#### CAUTION

DEF is mildly corrosive. It can corrode components that are made from incompatible material(s) and reduce their integrity. The use of incompatible material(s) may lead to leaks and spills, and can contaminate and degrade the DEF. When dispensing DEF, verify with the manufacturer if the material of all plumbing components are compatible with the DEF being dispensed.

#### CAUTION

Do not use Prover Cans meant for engine fuel with DEF or vice versa. Use stainless steel Prover Cans for DEF. DEF and engine fuel must not be mixed with each other or be contaminated by each other. Else, damage to a vehicle's engine or pollution control devices could occur. DEF crystallizes as its water base evaporates. Pouring out liquid will not guarantee that no corrosive DEF remains in the Prover Can. DEF must not be contaminated with Diesel fuel, contaminants, or other fluids or materials. Such contamination can cause serious damage to vehicle catalytic converters.

- Conventional fluid handling precautions are also applicable to DEF.
- Avoid contact with eyes, skin, and clothing. Ensure that eyewash stations and safety showers are close to the work location.
- DEF is mildly corrosive and non-flammable.
- Clean the DEF spill with water and dry the area with clean rags, especially areas that contain metallic parts. Spilt DEF can be slippery and will corrode certain types of metallic parts. Wear eye protection and rubber gloves during any cleanup activity.
- DEF is heavier than gasoline. Be aware that prover cans, containers filled with DEF, and so on will be considerably heavier than gasoline.

## Guidelines in AtlasX Fuel Systems Documentation and Other Codes

The following manuals provide guidelines for installing AtlasX Fuel Systems pumps/dispensers:

- *MDE-5692 AtlasX Fuel Systems Installation Manual*
- *MDE-5693 AtlasX Fuel Systems Site Prep Manual*
- *FE-371 Field Wiring Diagram*

Ensure that the installer follows the instructions in the above listed manuals and adheres to all applicable local, state, and national codes.

## General Guidelines

Ensure that the installer, at a minimum, performs the following tasks:

- Attaches the hose breakaways.
- Follows all manufacturer installation instructions for devices attached to the dispenser, such as hoses, nozzles, and shear valves.
- Installs a line leak detection system for all dispensers (The system must comply with all local and state codes).
- Uses only UL-listed or approved attachments with the pump/dispenser.
- Installs shear valves for all dispensers and certain above ground tank pump applications properly.
- Follows all codes.
- Bolts units to the island properly.
- Tests hoses for conductivity before use as per the manufacturer's instructions.
- Uses appropriate safety signs as outlined in the manuals listed in "[Guidelines in AtlasX Fuel Systems Documentation and Other Codes](#)".
- Uses isolation relays for dispensers (required by National Electrical Codes).
- Uses the recommended hose lengths for each unit unless you are using hose retrievers.

*Note: This is not a complete list. For other requirements, refer to "[Guidelines in AtlasX Fuel Systems Documentation and Other Codes](#)".*

## Hoses

Hoses must be UL approved and conductive from end-to-end. To determine the hose length, refer to “[Determining Hose Length](#)”.

*Note: When determining the hose length, the effect of adding breakaways adds significantly to the actual hose length.*

### **WARNING**

Hoses of excessive length may create a trip hazard.

Serious injury could occur as a result of tripping over an excessively long hose.

Do not use excessive length hoses. Also ensure that hose retrievers are installed and are in good operating condition.

Do not install soft-wall hoses, they commonly cause a small sale to indicate when the unit is activated and the nozzle is closed.

### Determining Hose Length

To determine the correct hose length for various types of hoses, refer to the following table.

Type	Length
Standard hardwall 5/8 or 3/4 ID (without breakaway)	10 feet, 6 inches
Standard hardwall 5/8 or 3/4 ID (with breakaway)	9 feet, 6 inches
Standard breakaway whip hose	1 foot, 0 inches

## Install Warning Labels and Signs for Customers

Install warning labels and signs to ensure that customers are warned of potential safety hazards. Ensure that the warning labels and the signs are readily visible. At a minimum, install the following signs:

- Turn off the vehicle before fueling.
- No smoking; do not use matches or lighters nearby.
- Use only non-breakable, approved containers for storing fuel; ensure that the container is metal and identified properly for fuel storage.
- Static electricity hazards during fueling.

Promptly replace any missing, incomplete, or illegible labels or operating instructions.

### **WARNING**

Static electricity can cause an explosion.

Static electricity, including an electrostatic charge on your body, can cause a spark sufficient to ignite fuels and their vapors.

After getting out of a vehicle, touch the metal of your vehicle to discharge any electrostatic charge before you approach the dispenser island.

# Operating Pumps/Dispensers

This section describes the operation of the pump/remote dispenser. It provides information on how to:

- Access the electronic components
- Set the standalone

If you are using a point of sale device, refer to the manufacturer instructions.

## Opening the Bezel Assembly

To change the settings and/or programming in Gasboy AtlasX 8800 or 9800 series pumps and dispensers, the bezel assembly must be opened. To open the bezel assembly for AtlasX 8800 or 9800 series pumps and dispensers, proceed as follows:

- 1 Unlock the front panel.
  - a Loosen and remove the two screws and washers holding the bezel door assembly.  
*Note: Retain the screws for re-installation. Right side of the bezel door is hinged.*
  - b Unlock the lock using a key.

**Figure 3-7: Bezel Door Assembly**

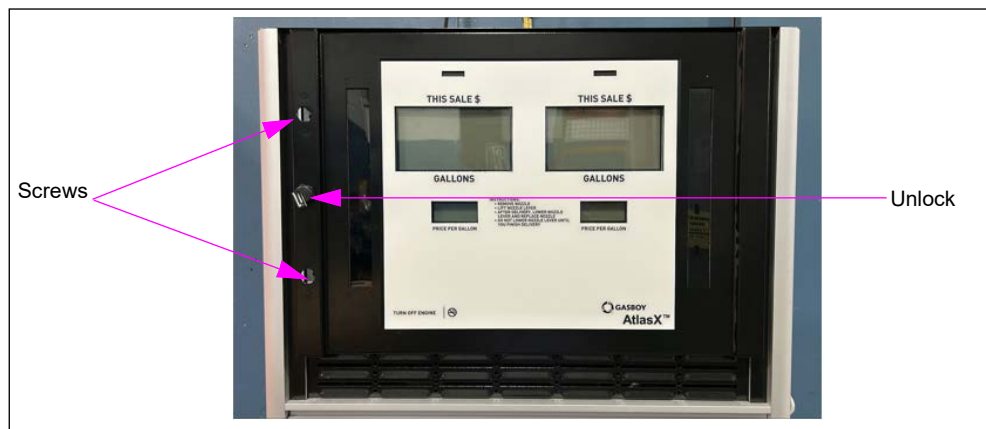

- 2 Open the bezel door 90 degrees until the prop rod engages.

**Figure 3-8: Opening the Bezel Door**



- 3 The bezel door will lock in place. Ensure that the door is locked in place before you proceed.

**Figure 3-9: Bezel Door Open**

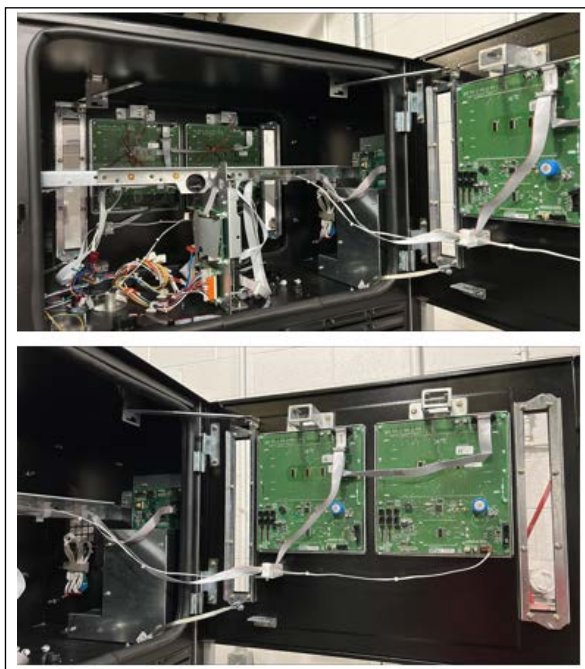

## Opening the Lower Panel Assembly

To access the lower panel, proceed as follows:

- 1 Unlock the lock using a key.

**Figure 3-10: Lower Panel Assembly**



- 2 Using the key in the lock, pull the door upward and then tilt outward.

**Figure 3-11: Opening the Lower Panel Door**



- 3 Remove the door by pulling up to unmount from the bottom hooks.

**Figure 3-12: Bottom Hooks**



## Reassembling the Lower Panel

To assemble the lower panel, proceed as follows:

- 1 Secure the door in the hooks on the bottom of the frame.

**Figure 3-13: Bottom Hooks**



- 2 Tilt the lower panel door back into position, aligning the slots on the door with the hooks.

**Figure 3-14: Closing the Lower Panel Door**



- 3 Lock the door using a key.

**Figure 3-15: Locking the Lower Panel Assembly**



## Electronic Component Access

This section describes the operation of the pump/remote dispenser. It provides information on how to:

- Access the electronic components
- Set the internal jumpers
- View the electronic totalizers using the manager’s keypad
- Operate both pumps and remote dispensers

## Programming 8800/9800 Models

### Programming the 8800/9800 Series Electronic Units

This section describes the Level 1 programming procedures and considerations for the 8800/9800 series.

**Figure 3-16: Programming of 8800/9800 Series Electronic Units**

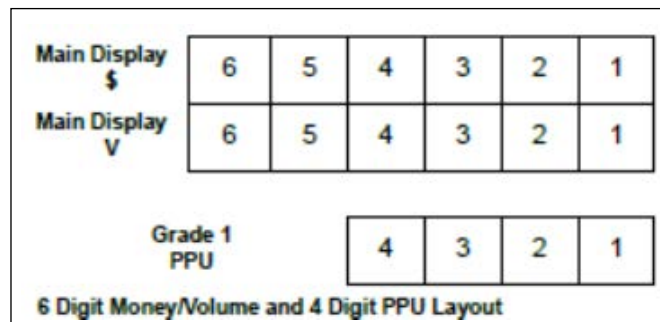

## Level 1 Programming and Data Access

**Figure 3-17: Manager’s Keypad**



## Manager Keypad Key Definitions and Use

Key(s)	Definition/Use
0-9	Numeric Values
F1	Function 1 – Used to start dispenser programming and sequence among programming and function codes. In general, each depression of F1 key will take user back to a previous programming function selection. Depressing F1 from the normal dispenser state will always initiate programming mode. <i>Note: Displays are always activated during programming mode.</i>
F2	Function 2 – Used to exit programming mode and return to normal mode. A unit warmstart also occurs after pressing F2 while in the programming mode.
\$Totals	Money Totals – Used to display money totals by side and grade. This key does not require a security code. <b>CLEAR</b> key is used to exit money totals mode.
Vol. Total	Volume Totals – Used to display volume totals by side and grade. This key does not require a security code. <b>CLEAR</b> key is used to exit volume totals mode.
ENTER	Value entry keys – sends the entered value to pump.
CLEAR	Clear key – Used to clear last keypad entry and exit money and volume total mode.

## Programming Steps

(In standalone mode, programming can be entered at any time by going to step 3.)

- 1 Authorize pump from POS or FCC.
- 2 Send PUMP STOP from POS or FCC (repeat steps 1 and 2 three times) \*.  
*Note: Once unlocked, the unit will remain unlocked for five minutes to allow access.*
- 3 Press F1.
- 4 Enter PIN code for higher-level programming as required (see below).
- 5 Toggle the Weights and Measures (W&M) switch to the ON position if required.
- 6 Program the unit as required.
- 7 When finished programming, toggle the W&M switch to the OFF position.
- 8 Press F2 to exit programming.  
*Note: \*If there is no POS or FCC or this is not possible with the controller being used, disconnect the current loop connection, and wait for the double beep (about 5 minutes).*

## Security/PIN Code Entry

It is strongly recommended that the appropriate station authority change/reset the security codes to enhance security. The security codes default factory settings are shown below.

## Programming Quick Reference: AtlasX

### Command Codes and Function Codes Quick Reference Chart

The following chart shows level command codes and function codes where applicable. Refer to the following pages for more details.

Level	Command Code	Function Code
<b>Level One Command Codes</b>	19 Set AtlasX Related Options	1 Set Pulse Out Mode
		2 Set Pulse Output Rate per Volume Unit
		3 Blank Money and PPU Display
	20 Set PPU Values	
	22 Set Preset Types and Values*	1 Set Preset Type
		3 Set PPU On/Off
		2 Set Preset Amounts
	24 Set Operations Mode	1 Two Wire
		2 Standalone/Pulse out
		3 IFSF
	25 Set Allocation	
	27 Review ATC	1 Audit Last Transaction
		2 Display Volume Correction Factor
		3 Display Fuel Density
		4 Display Temperature
5 Gross Volume Totals		
6 Software Version		
7 Real-Time Transaction		
8 Engineering Audit		
28 Change First Level PIN		
31 Money Allocation		
<b>Level Two Command Codes</b>	40 Set Two-Wire ID (pump number)	
	41 Set PPU Options	
	42 Set Decimal Point Options	1 Main Display Money
		2 Main Display Volume
		3 PPU for Calculations
		4 PPU for Display
	43 PPU Blinking Options	
	45 Set Lamp Test Time	
	46 Set Comma/Decimal Point	
	47 Set Reported Money Size	
	48 Zero Previous Transaction	
	49 STP Controls	1 Set STP Prestart
		2 Set STP Control
	51 Set Main Beeper	
	52 Set VaporVac Alarms*	
53 Set Time Outs	1 Set Beeper	
	2 Set Pre-Select	
	3 Set Dispenser	

Level	Command Code	Function Code
<b>Level Two Command Codes</b>	54 Slowdown Volume	
	55 Set Hose Pressurization	
	56 Set Stop Button Control*	
	58 Steering Valve to Nozzle Assignment*	
	59 System Reset Start	
	60 Set Clock and Calendar	
	62 Two-Wire Remapping Grade*	
<b>Level Three Command Codes</b>	71 Set Volume Units	
	72 Set Blend Ratios*	
	73 Set/Display Money Totals	
	74 Set/Display Volume Totals	
	75 Set Fuel Density	
	76 Display Rounding Method*	
	77 Change PIN Code	1 Level One
		2 Level Two
		3 Level Three
		4 Level Four
	80 Set Maximum Flow Rate	
	82 Calibration Can Size	
	83 Alternate and Third-party Fuel Modes	1 Set Alternate Fuel Hydraulics Setup
	2 Set Alternative Fuel Type	
	3 Alternative Fuel Equivalency	
<b>Level Four Command Codes</b>	84 Pulser Type*	
	90 Set Unit Type	
	91 Select Installed Options	1 Preset Type*
		2 Push to Start*
		3 Set VaporVac*
		5 Set Push to Stop*
		6 Set ATC
		7 Grade Select Function*
		8 Protection Method*
		9 Preset Indicator*
		11 Set Totalizer function
		12 Set Nozzle activated Pump Handle*
		26 Set Operation Mode Protection
		30 Pulser Error Reporting
		31 Unauthorized Flow Error
		32 Preset Roundup Minimum*
		33 Price Change Method
		34 Door Switch Method
		37 Door Switch Reporting*
	38 Door & Hydraulics Panel Alarms*	

Level	Command Code	Function Code
Level Four Command Codes	91 Select Installed Options	39 DEF/ARLA/Adblue Cold Weather Warning*
		40 Log Language
		41 Hydraulics Panel Switch Monitoring*
		42 Hydraulics Panel Switch Reporting*
		43 Hose Leak Test
		45 Special Option for Door Security*
		47 PC Serial Communication Protocol
		49 Nozzle Guard Time
		92 Set Side Exits
		94 Set Zero PPU Option
		96 Feature Set*
		98 Inlet Assignment Per Grade for Universal Blender*

Note: \*Not used with AtlasX. Leave at the default value.

The following section contains the Command Codes/ Function Codes used to set up an AtlasX electronic pump/dispenser. For a full list of Command Codes/Function Codes, refer to *MDE-5694 AtlasX Start-up/Service Manual*.

### Command Code 19: Set AtlasX Related Options

- Press **1, 9**, and then press **ENTER**.

#### Function Code 1: Set Pulse Out Mode

- Press **1** and then press **ENTER**.
- Press Configuration number and then press **ENTER** where:
  - 1 = Disabled\*
  - 2 = Enabled (Activate Pulse Out Mode, unit must be set for stand-alone, CC24 set to 2)

#### Function Code 2: Set Pulse Out Mode

- Press **2** and then press **ENTER**.
- Press Configuration number and then press **ENTER** where:
  - 0 = Not Programmed\*
  - 1 = 1 Pulse per Volume Unit
  - 2 = 10 Pulse per Volume Unit
  - 3 = 100 Pulse per Volume Unit
  - 4 = 250 Pulse per Volume Unit (N/A for liters)
  - 5 = 500 Pulse per Volume Unit (N/A for liters)

#### Function Code 3: Blank Money and PPU Displays

- Press **3** and then press **ENTER**.
- Press Configuration number and then press **ENTER** where:
  - 1 = Disabled\*
  - 2 = Enabled (Blank \$TOTAL and PPU displays, must be enabled for 9800 series units)

### Command Code 20: Set PPU Values

- Press **2,0** and then press **ENTER**.
- Select Side [1, 2, or 3 (both)] and then press **ENTER**.
- Select **Grade** and then press **ENTER**. (Should always be Grade 1 for AtlasX)
- Select **Price Level** and then press **ENTER**. (Should always be Grade 1 for AtlasX)
- Enter new PPU and then press **ENTER**.

(Repeat for other Side, Grade, and Price Level)

### Command Code 24: Set Operations Mode

- Press **2,4**, and then press **ENTER**.
- Press Configuration number and then press **ENTER** where  
0 = Standalone mode or Pulse Out  
1 = Two-wire mode (default)

## Level 2 Programming

### Command Code 40: Two-wire ID (Pump Number)

- Press **4, 0**, and then press **ENTER**.
- Select side **1** (A) or **2** (B) and then press **ENTER**.
- Enter ID 1 - 16 and then press **ENTER**. (Side 1 = 7; Side 2 = 11 are the default settings)

### Command Code 60: Set Date/Time Functions

- Press **6, 0**, and then press **ENTER**.

#### Function Code 1: Set Unit Time

- Press **1** and then press **ENTER**.
- Enter time (HHMM) and then press **ENTER**. (Time is entered in a 24-hour format)

#### Function Code 2: Set Unit Date

- Press **2** and then press **ENTER**.
- Enter date (MMDDYY) and then press **ENTER**.

#### Function Code 3: Set Unit Daylight Savings Time Mode

- Press **3** and then press **ENTER**.
- Enter number (see values below) and then press **ENTER**.  
1 = Disabled (default)  
2 = USA  
3 = Canada  
4 = Mexico

## Level 3 Programming

### Command Code 71: Set Volume Units

- Press **7, 1**, and then press **ENTER**.
- Enter number (see values below) and then press **ENTER**.  
0 = None (default)  
1 = US Gallons  
2 = Liters  
3 = Imperial (UK) Gallons  
4 = Reversed  
5 = Hawaiian Gallons

**Command Code 77: Change PIN Codes**

PIN Codes are a security feature. Changing PIN Codes from default can enhance station security. Revised PIN Codes must be safely stored at the site and ASC such that they can be accessed, as required. They must not be misplaced or lost. For more on resetting PIN Codes, refer to the MDE-5694 AtlasX Start-up/Service manual.

*Note: PIN Code **must** be entered twice.*

This CC allows the programmer to set new PIN Codes to enter the four different programming levels. When accessed, all codes are shown as “- - -”. Entering new digits for new codes changes the display, as they are entered. The display does not show the actual PIN digit but shows “0” to denote that a number was entered. The same PIN Code must be entered twice for it to be allowed. The first pass at entering a PIN Code is signaled by “1” appearing in the Pass Code display (last digit of the \$Total). The second pass is signaled by “2” in the Pass Code display. Acceptance of a PIN Code is signaled by “3” appearing in the Pass Code display. A “0” in the Pass Code display indicates that the PIN Code was unaccepted.

To change the PIN CODES:

- Press **7, 7**, and then press **ENTER**.
- Press **X** (where X is the level 1-4 of the PIN Code being changed) and then press **ENTER**.
- Enter the new code (4 digits) and then press **ENTER**. (**2** will be displayed in the last digit of the \$Total).
- Enter the new code again and then press **ENTER**. (If accepted, **3** will be displayed).

If the pass number display (last digit of the \$Total) shows the value of “0”, it indicates that the first and second PIN Code entries did not agree. Press F1 to start the PIN Code entry sequence from the beginning. If the new code is entered correctly twice, the pass number display will display a value of 3 to indicate the acceptance of the new PIN Code.

**Command Code 80: Set Maximum Flow Rate**

- Press **8, 0**, and then press **ENTER**.
- Select side **1** (A) or **2** (B) and then press **ENTER**.
- Press **1** and then press **ENTER**. (AtlasX only has 1 grade per side)
- Press **9, 8**, and then press **ENTER**.\*

*Note: \*Flow rate must be set to 98 for AtlasX. For retail units that require flow control of 10 GPM or less, an external flow restrictor must be used.*

**Command Code 82: Set Calibration Can Size**

- Press **8, 2**, and then press **ENTER**.
- Select side **1** (A) or **2** (B) and then press **ENTER**.
- Enter calibration can size in whole units (1-999) and then press **ENTER**.  
Default can size is 5 for gallons (US or Imperial) or 20 for liters.

**Level 4 Programming****Command Code 90: Set Units Type**

- Press **9, 0**, and then press **ENTER**.
- Press **1, 0**, and then press **ENTER**.\*

*Note: \*For AtlasX models, the unit type should be set to 10. The default unit type is 1, which will also work for AtlasX single units.*

**Command Code 91: Select Installed Options**

- Press **9, 1**, and then press **ENTER**.
- Press **1, 1**, and then press **ENTER**.\*
- Enter number (see values below) and then press **ENTER**.
  - 1 = Disabled (default)
  - 2 = Enable totalizer per meter/side (AtlasX setting)
  - 3 = Enable totalizer per inlet

*Note: \*The ATC (see later in this section) and totalizer are the only options that should be changed from their default value for AtlasX. Refer to the MDE-5694 AtlasX Start-up/Service manual for a full list.*

**Command Code 92: Set Side Exists**

- Press **9, 2**, and then press **ENTER**.
- Enter number (see values below) and then press **ENTER**.
  - 1 = Both Sides exist (default)
  - 2 = Side 1 Only (Set for Single units)
  - 3 = Side 2 Only

**AtlasX Error Codes**

- Error Codes (E1 - E11) are displayed on the Main Money display.
- Error Codes (20 - 5614) that appear on the PPU display when an error occurs are useful in diagnosing problems with the pump/dispenser. For a full list of error codes, refer to *MDE-5694 Start-up/Service Manual* or *MDE-3860 Programming Quick Reference Guide*.

## ATC Programming

Use the following Command Codes/Function Codes to enable ATC (Automatic Temperature Compensation) when the unit is equipped with the ATC components (temperature probes, M18983A001 ATC-I.S. Barrier-Tmeter PCA, etc.) and ATC is required at the site location.

### Command Code 71: Set Volume Units

- Press **7, 1**, and then press **ENTER**.
- Enter the number (see values below) and then press **ENTER**.
  - 0 = None (default)
  - 1 = US Gallons
  - 2 = Liters
  - 3 = Imperial (UK) Gallons
  - 4 = Reversed
  - 5 = Hawaiian Gallons

### Command Code 75: Set Fuel Density

- Press **7, 5**, and then press **ENTER**.
- Select side **1 (A)** or **2 (B)** and then press **ENTER**.
- Press **1** and then press **ENTER**. (AtlasX only has 1 grade per side)
- Enter the number (see values below) and then press **ENTER**.
  - 0 = Not programmed (default)
  - 1 = Gasoline (730)
  - 2 = Diesel (840)

### Command Code 91: Select Installed Options

- Press **9, 1**, and then press **ENTER**.
- Press **6**, and then press **ENTER**.
- Enter the number (see values below) and then press **ENTER**.
  - 1 = Disable (default)
  - 2 = Enable

## ATC Review Mode

Command Code 27 is entered in Level 2 programming to access ATC data. Function Codes in this programming level provide read-only access to ATC operating parameters. No changes can be made to operating parameters at this level. Default FC (1) provides an audit of the last transaction data.

### Command Code 27: Set Volume Units

- Press 2, 7, and then press ENTER.
- Enter the number (see values below) and then press ENTER.

1 = (Default) Audit last transaction:

Provides display of uncompensated and compensated product volumes (single meter) in main money and volume displays respectively. The average transaction temperature is shown in the PPU display for the selected meter. ATC data is reported after inlet selection has been entered in the main volume display.

2 = Display Volume Correction Factor (VCF):

Provides display of VCF for a selected product (meter). VCF is based on the currently sensed meter temperature. ATC data is reported after meter selection has been entered in the main volume display.

3 = Display fuel density:

Provides display of density for a selected meter. Displayed density for a particular grade reflects the density assignment made in Level 4 programming. ATC data is reported after grade selection has been entered in the main volume display.

4 = Display temperature:

Provides display of the temperature in Celsius for a selected meter.

5 = Display gross volume totals:

Provides display of gross volume totals for a selected meter.

6 = Display software version:

Provides display of ATC neuron software version number.

### Real-time Data Review - ATC

When a dispenser is configured to use ATC, it has a requirement to perform a running transaction to show Uncompensated Volume, Compensated Volume, and Temperature for Audit Review of the system. When a transaction is being performed on one side of the dispenser, the user can press 7 on the manager keypad to have the Uncompensated Volume replace Money information and have Temperature replace the Price in the PPU. Pressing 7 again will return the data to the normal Money/Volume/PPU display. If a handle is lowered or an error occurs to end the transaction, the Money/Volume/PPU will be displayed. This transaction is also counted for all totalizers and reported to any controller over 2-wire communications if configured.

## ATC Specific Error Codes

Error Code	Description
5091	ATC node communication failure
5092	ATC node present but not configured for ATC
5093	ATC node software download successful
5094	ATC node software download Authentication
5095	ATC node software download CRC error
5096	ATC node software download Flash error
5097	ATC node software download Incomplete
5098	T-Meter not connected
5099	ATC - number of probes exceeds the number of meters
5100	ATC - number or meter exceeds the number of probes
5101	No Pulse train detected from T-meters (T-meter is connected)
5600	Fuel Density note not programmed
5601	ATC temperature out of range
5602	ATC node incorrect software version
5606	ATC node subscription failed
5609	ATC software is not up to date

**Figure 3-18: Manager's Keypad**



## Displaying Pump Totals

During service, it is often required to access pump totals. This can be done at the POS or at the pump/dispenser. Access is simple through the manager keypad.

### To View Side 1 Totals:

- 1 Press **\$TOTAL**. Combined cash and credit total appears for Grade 1, Side 1.
- 2 Press **VOL TOTAL**. The volume total appears for the grade selected.
- 3 Press **Enter** to view Side 2 totals.
- 4 Press **Clear** to exit.

## Shear Valve

### **WARNING**

High alcohol percentage fuels such as E85 or fluids such as DEF may be incompatible with certain plumbing materials and hydraulic components.

Use of incompatible materials or components with E85 can result in leaks. For E85, unexpected failures of components may also occur resulting in fire or explosion or environmental damage. .

When dispensing alternative fuels such as E85 or fluids such as DEF, verify with the manufacturer if the material of all plumbing components are compatible with the fuel (E85) or fluid being dispensed.

*Note: The AtlasX 9862 utilizes a special shear valve manufactured by OPW, model 60.*

Shear valves, required by NFPA 30A, are intended to shut-off the flow of fuel at the dispenser base (hydraulics area) during vehicle impact or fires. A single-poppet shear valve prevents the fuel flowing from the underground tank. A double-poppet shear valve prevents fuel flowing from the underground tank and the dispenser. In an event that the product fails to exit the dispenser/pump hose, ensure that the shear valve is not closed.

A shear valve in the open position is shown in [Figure 3-19](#) on [page 3-28](#).

*Note: The shear valve is located inside the dispenser on the lower cross brace in the pit box area.*

Figure 3-19: Open Position of Shear Valve

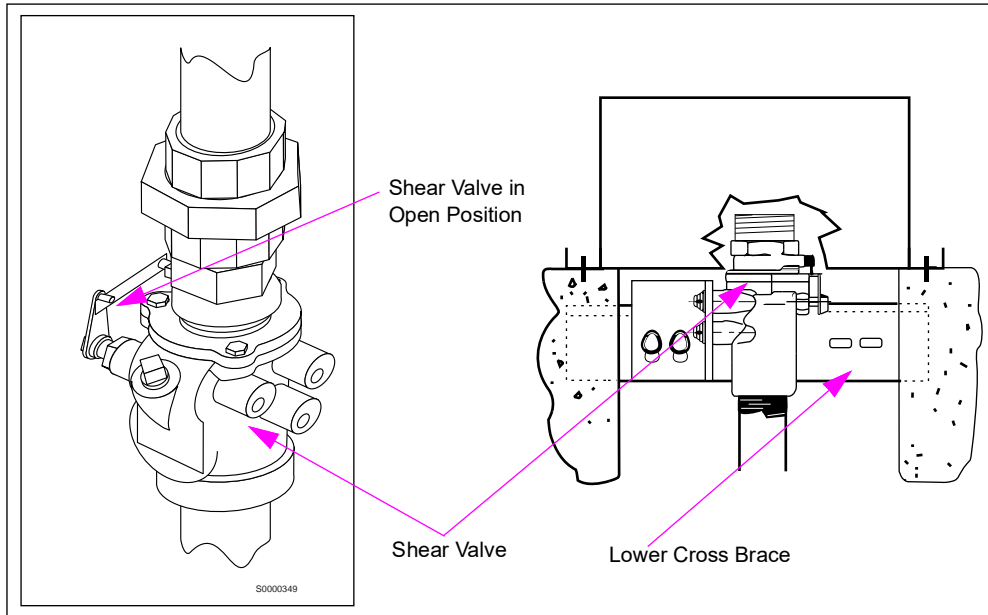

**⚠ WARNING**

Shear Valves may stick parochially in the open position causing fuel to flow through a shear valve thought to be closed. Always test for proper closing by attempting to dispense fuel into an approved container. Fuel must not continue to flow after pressure has been relieved.

For maintenance information, refer to “Preventive Maintenance Table” on page 3-48.

**Figure 3-20: Closed Position of Shear Valve**

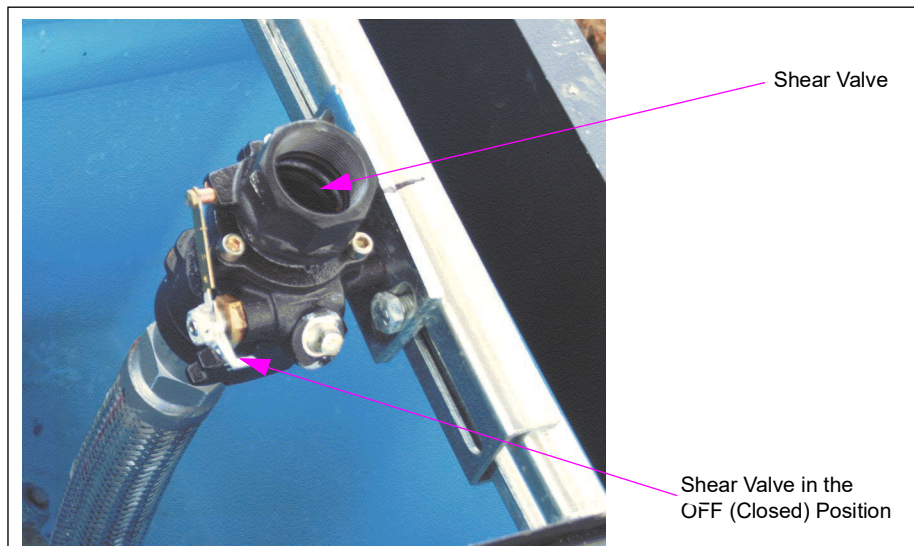

**Figure 3-21: OPW Model 60 Shear Valve**

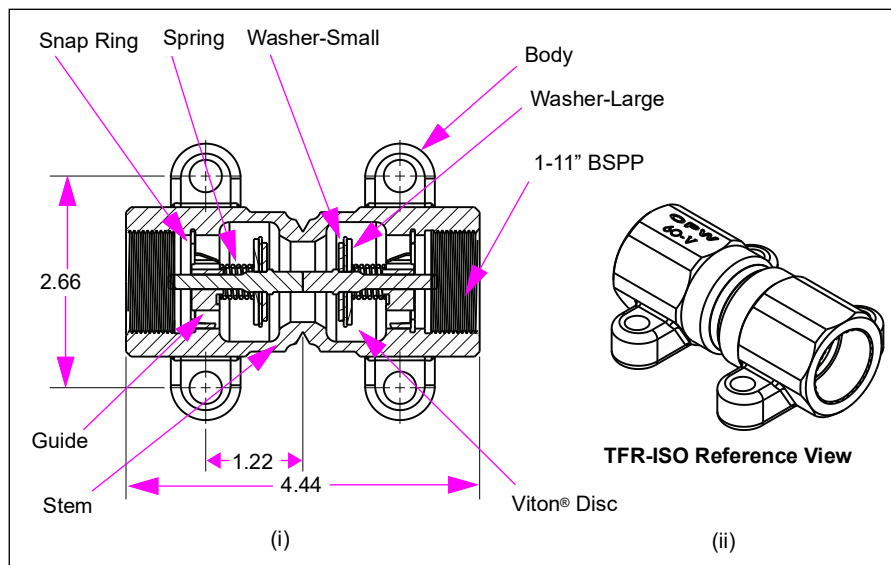

# Operating Sequence for Series 9100 Only

## Pump

- 1 AC Power (115/230 VAC International) must be provided to the pump motor control and the reset the motor feed (solenoid valve feed, if applicable).
- 2 When the pump handle is switched on, power (115/230 VAC International) is supplied to the electric reset motor, which immediately begins to reset the values on the pump's non-computer register to zero.
- 3 When the reset is complete, power is removed from the reset motor and the internal switches in the reset unit change to the normally open contacts. This supplies power (115/230 VAC International) to the pump motor control and to the reset complete/solenoid valveline. If this pump contains a slow flow/fast flow or closure type solenoid valve, the valves will open at this time.
- 4 The user begins to dispense fuel.
- 5 The register displays the total volume. If an optional pulser kit is attached, it supplies pulses which may be recorded by an external Fuel Management System such as the Gasboy Islander PRIME.
- 6 The fueling transaction continues to run until the user turns off the pump handle.

## Remote Dispenser

- 1 AC power (115/230 VAC International) must be provided to the submersible feed and solenoid valve feed and reset motor feed. If a submersible starter relay is used, AC power (115/230 VAC) must be supplied to the input contacts of the submersible starter relay.
- 2 When the pump handle is switched on, power (115/230 VAC International) is supplied to the electric reset motor which immediately begins to reset the values on the pump non-computer register to zero.
- 3 When the reset is complete, power is removed from the reset motor and the internal switches in the reset unit change to the normally open contacts. This supplies power (115/230 VAC International) to the submersible starter relay, which in turn closes and supplies power to the submersible motor. If a starter relay is not used, the hot leg is supplied directly to the submersible motor. The remote dispenser contains a slow flow/fast flow or closure type solenoid valve, which opens at this time. At the same time that the valve opens, the Reset Complete line goes to 115/230 VAC International.
- 4 The user begins to dispense fuel.
- 5 The register displays the total volume. If an optional pulser kit is attached, it supplies pulses which may be recorded by an external Fuel Management System such as the Gasboy Islander PRIME.
- 6 The fueling transaction continues to run until the user turns off the pump handle.

# Operating Sequence for Electronic Series

The exact sequence of events that occur during the operation of the pump or remote dispenser is determined by various programming options, inputs, and the user. A typical transaction is explained below:

## Self-Contained Pumping Unit

- 1 Turn on the pump handle. The reset cycle begins. The display (Electronic units):
  - Goes blank for one second.
  - Shows all 8s for one second.
  - Goes to 0.000 (gallons) or 0.00 (liters) until fuel starts.

The pump motor switches on and the Reset Complete line becomes active.

- 2 The pump continues to run until one of the following conditions occur. These conditions switch off all relays as follows:
  - The handle is turned off.
  - In Pulse Out Mode, the AUTH line is switched off by the POS or fuel management system.
  - A pulser error is detected.
  - A time-out is reached (if the unit is programmed with a time out value). If connected to a fuel management system, the time-out loaded into the system is used (commercial electronic only). The unit turns off if it is idle for a preprogrammed time when no fuel is flowing.
  - A quantity of 990.000 gallons (9900.00 liters) is reached. If connected to a fuel management system, the limit set in the system is used.
  - The pump is halted by an operator of a fuel management system.
  - An AC power failure occurs.
  - Station Emergency Stop button is pressed.

## Dispenser Units - Fueling Unit with No Motor and Pump in the Bottom

- 1 Turn on the pump handle. The reset cycle begins and the submersible pump switches on. The display (Electronic Unit):
  - Goes blank for one second.
  - Shows all 8s for one second.
  - Goes to 0.000 (gallons) or 0.00 (liters) and remains until fueling begins.
- 2 The user begins to dispense fuel.

- 3 The remote dispenser continues to run until one of the following conditions occurs. These conditions turn off all relays as follows:
- The handle is turned off.
  - In Pulse Out Mode, the AUTH line is turned off at the POS or fuel management system.
  - A pulser error is detected.
  - A time-out is reached (if the unit is programmed with a time out value). If connected to a fuel management system, the time-out loaded into the system will be used (commercial electronic only). The unit will turn off if it is idle for a preprogrammed time when no fuel is flowing.
  - A quantity of 990.000 gallons (9900.00 liters) is reached. If connected to a fuel management system, the limit set in the system will be used.
  - The pump is halted by an operator of a fuel management system.
  - An AC power failure occurs.
  - Station Emergency Stop button is pressed.
  - Several error conditions (Error Code displayed on PPU display)

## Error Codes

Error Codes (E1 - E11) are displayed on the Main Money display.

Error Codes (20 - 5616) that appear on the PPU display when an error occurs are useful in diagnosing problems with the pump/dispenser.

*Note: Not all possible error codes are listed below.*

For more error code information, refer to *MDE-3860 Programming Quick Reference Guide*.

### E1 - E12

Code	Description	Level
E1	Database Corrupted	Super Major
E2	Flash Corrupted. Press F1/F2 to clear.	Super Major
E3	LON configuration error	Not available on AtlasX
E4	One or more tasks not started	Super Major
E5	Coldstart was forced	Super Major
E6	Redundant data storage error	Super Major
E8	Data base changed, set as default the new values	Super Major
E10	Software updated, Security Switch NOT ON	Information only
E11	Software DSS changed, Security Switch NOT ON	Information only
E12	Restore Calibration from Door Node	Information only

### 0 - 50

Code	Description	Level
20	Pulser connected and the product is not mapped	Super Major
20	Pulser Disconnected/Error	Super Major
24	Volume unit type not set	Major
26	Pump not calibrated	Major
27	Two-wire ID changed side A	Undefined

Code	Description	Level
28	Two-wire ID changed side B	Undefined
29	Valve not open	Medium
30	VaporVac power supply or cabling failure	Not available on AtlasX
31	DEF dispenser lines frozen	Information only
33	Push-to-Stop activated	Not available on AtlasX
35	Configuration data error	Medium
37	Pin code 1 changed	Undefined
38	Pin code 2 changed	Undefined
39	Cash/Credit option changed	Not available on AtlasX
41	Side exists option changed	Undefined
42	Fill/Authorization Timeout	Undefined
44	Pump handle on at power up	Medium
46	Minimum Preset -	Not available on AtlasX
50	Two-wire communications lost (disconnected)	Minor

**4000 - 4999**

Code	Description	Level
4321	Valve stuck	Super Major
4322	Valve board not responding	Super Major

**5000 - 5099**

Code	Description	Level
5024	ATC enabled	Undefined
5025	ATC disabled	Undefined
5026	ATC base value changed	Undefined
5027	Sealable switches have been accessed	Undefined
5028	Measurement unit volume changed to liters	Undefined
5029	Measurement unit volume changed to gallons	Undefined
5030	Measurement unit volume changed to Imp. gallons	Undefined
5031	Measurement unit volume changed Hawaiian gallons	Undefined
5041	Power Fail-Power circuit registers a power loss	Undefined
5047	Reverse flow detect	Medium
5048	No flow detect	Minor
5049	Unauthorized flow detected	Medium
5050	Invalid Pulser-Pulser Pattern does not fit profiled meter	Medium
5056	Transaction started with Security Switch ON	
5066	STP 1 configured for but not connected	Super Major
5067	STP 2 configured for but not connected	Super Major
5079	Valve Not Configured for but is responding	Minor
5091	ATC option set but ATC Node not detected	Super Major
5092	ATC node present but not configured	Minor
5098	T-Meter Not Connected	Super Major

**5100 - 5199**

<b>Code</b>	<b>Description</b>	<b>Level</b>
5100	ATC - number of meters exceeds number of probes	Medium
5101	ATC T-Meter pulse train not detected	Super Major
5111	Door Node Communication Failure	Super Major
5115	Door Node Download Error Medium	
5116	Door Node software download incomplete	Medium
5126	Key stuck on the Manager Keypad	Minor
5151	Door Node not addressed correctly	Major
5171	Power Fail Manager Keypad mode exited	Undefined
5183	Totalizer present but no return pulse detected	Major
5198	Measurement unit changed not programmed	Undefined
5199	Measurement unit changed 500 pulses per gallon	Undefined

**5600 - 5616**

<b>Code</b>	<b>Description</b>	<b>Level</b>
5600	Fuel density not programmed	Super Major
5601	ATC temperature out of range	Medium
5602	Door Node Software updated, Security Switch NOT ON	Minor
5603	ATC Node Software updated, Security Switch NOT ON	Minor
5606	ATC Node Communication Failure	Super Major
5607	Door Node Communication Failure	Super Major

## Electronic Calibration

Current AtlasX units are pre-calibrated at the factory, but calibration must be verified during installation. Verify calibration after recalibrating the unit. A unit type (CC 90) and volume units (CC 71) must be programmed into a unit before it can be calibrated. Ensure that the can size in CC 82 matches the calibration that can be used. Purge a minimum of 35 gallons for new units, 25 gallons after major dispenser service (meter replacement and so on), or 10 gallons for minor service (filter change, hose change, and so on) before any calibration verification or recalibration.

- 1 Connect the manager's keypad to the Combi display board (P6405).
- 2 Remove the nozzle and lift the lever of the hose (meter) to be calibrated.
- 3 Dispense product in calibration can be exactly to the zero mark.
- 4 Do not hang up nozzle. Turn ON/OPEN the ECAL/security switch by sliding it as shown below (It will be necessary to slide the security bracket up to allow the switch to be moved).

**Figure 3-22: Turn ON/OPEN ECAL Security Switch**

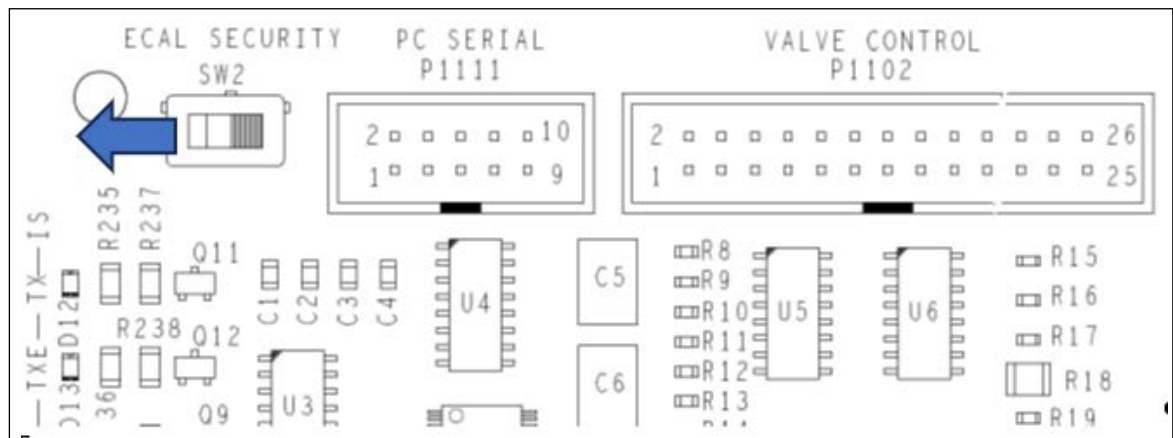

- 5 Wait for a double beep.
- 6 Lower the pump handle lever and hang up the nozzle.

- 7 Turn OFF/CLOSE the ECAL/security switch by sliding it in the opposite direction.

**Figure 3-23: Turn OFF/CLOSE ECAL Security Switch**

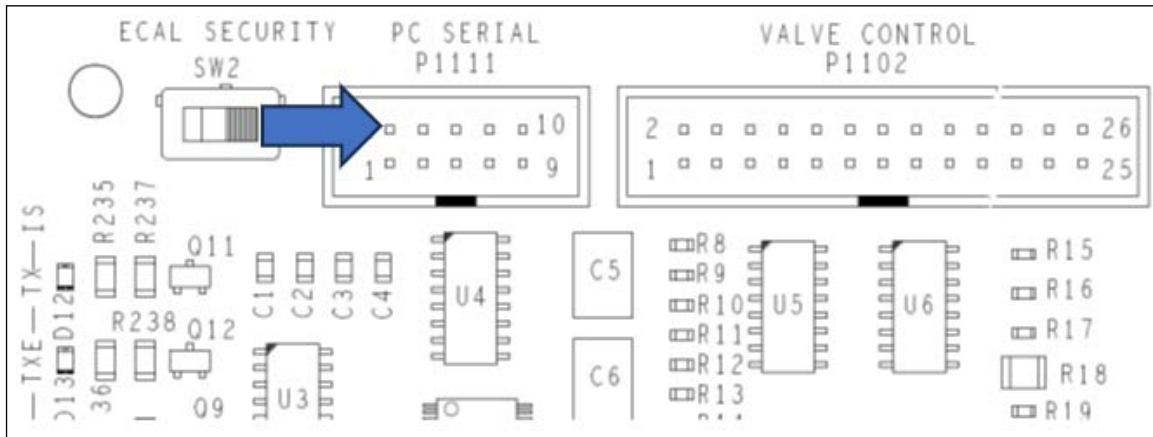

- 8 Enter the level 4 PIN code. You **do not** need to press F1.
- 9 Press ENTER and wait for a double beep.

For dual units, repeat the steps for the second side. The meter is now calibrated. The ECAL/security switch should be sealed.

- Notes:*
- 1) The above method will not be affected if steps 6 and 7 are reversed.
  - 2) For Automatic Temperature Compensation (ATC) units, gross volume can be displayed on the money display by pressing 7 on the manager keypad.
  - 3) Electronic totals ARE updated when this method is used.

Error code 26 on the Price Per Unit (PPU) display means a unit does not have a calibration factor. If error code 26 is displayed, use the following procedure:

- 1 Turn ON/OPEN the ECAL/security switch by sliding it as shown below (It will be necessary to slide the security bracket up to allow the switch to be moved.). The Price per Unit (PPU) displays contain the number of days since the last calibration for each meter. The Least Significant Digit (LSD) of money contains the Volume Unit Type (1 = USG, 2 = Liters) and the 3 Most Significant Digits (MSD) of money contain the calibration can size. An alternate can size can be programmed in CC 82.

**Figure 3-24: Turn ON/OPEN ECAL Security Switch**

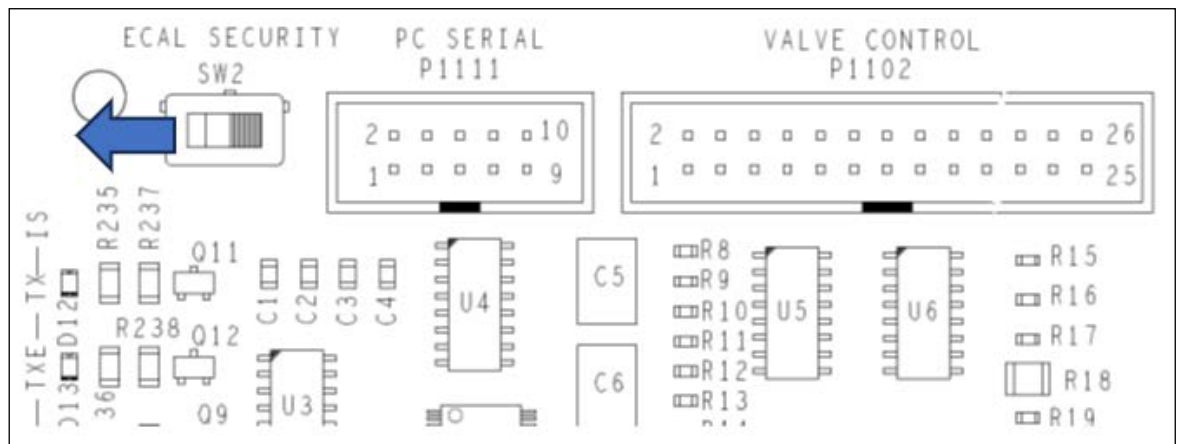

- 2 Enter the level 4 PIN code.
- 3 Remove the nozzle and lift the lever of the hose (meter) to be calibrated.
- 4 Dispense product in calibration can be exactly to the zero mark. The volume display will show the number of uncalibrated pulses.
- 5 Lower the pump handle lever & hang up the nozzle.
- 6 If calibrating a dual unit, calibrate the second hose (meter) by repeating steps 3 through 5.
- 7 If all meters have been calibrated, turn OFF/CLOSE the ECAL/security switch by sliding it in the opposite direction.

Figure 3-25: Turn OFF/CLOSE ECAL Security Switch

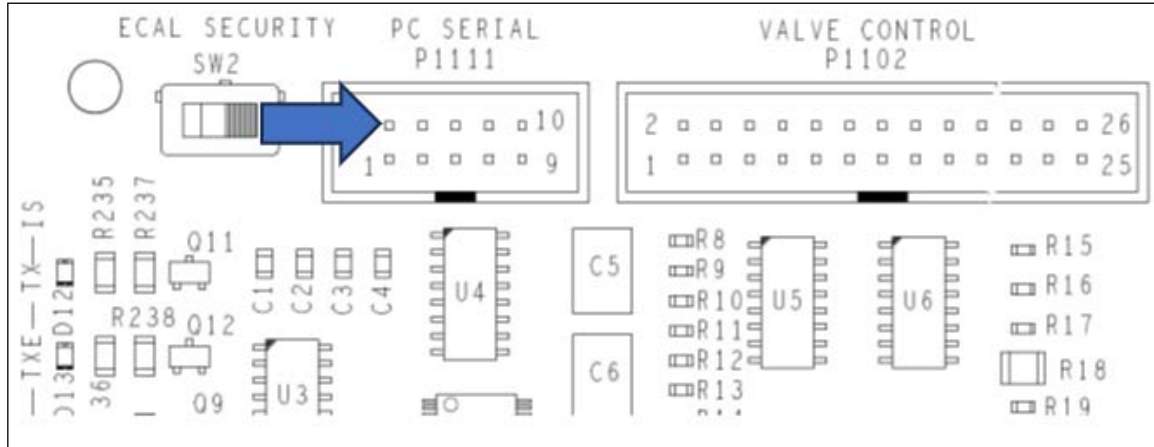

The meter(s) are now calibrated. The ECAL/security switch should be sealed.

*Note: Electronic totals are not updated when this method is used*

## Start-up and Test Section for Electronic Series

### Installation Completion Checklist

Review the following information to verify the proper installation of the Electronic Series dispensing unit. If the installation does not meet the criteria listed, correct the problem before the start-up is performed.

- 1 To avoid damage to the internal PC board, verify that the RESET COMPLETE, FAST FLOW, SUBM. STARTER DRIVE, and SLOW and FAST SATELLITE RETURN wires are not shorted to the conduit or chassis.
- 2 The unit must be secured to the island properly.
- 3 All plumbing must be complete and tight. All liquid-carrying lines must be checked for leaks.
- 4 When DC pulser or Pulse out lines are used in the pump for connecting to Gasboy fuel management systems, the AC and DC wires must not share any conduits, junction boxes, or troughs.
- 5 All conduit work must be complete. All junction box covers must be secured. Conduits must not be sealed until the wiring is verified through proper operation.
- 6 The unit must be grounded properly.
- 7 Before any testing begins, remove any water in the tank through a fill opening, using a suitable pump.  
*Note: Do not use the Gasboy pump or remote dispenser and submersible pump to remove water. Serious damage may occur.*
- 8 A sufficient volume of fuel must be put in the tank to ensure that the liquid level is above the bottom of the suction pipe (suction pumps) or is high enough to allow the submersible pump to operate efficiently (remote dispensers).

## Start-up

After successfully verifying the installation against the completion checklist, the unit is ready for start-up. To perform an orderly start-up of the Electronic Series, proceed as follows:

- 1 Turn the circuit breakers on for the CD Module and brand panel lights. Verify if both lights are lit.
- 2 Authorize the hose for Side 1 through the fuel management system, if available.
- 3 Remove the nozzle for Side 1 from its holder and turn the pump handle on. Verify that the display goes through the reset sequence as explained in [“Operating Sequence for Electronic Series”](#) on [page 3-31](#).
- 4 Dispense fuel. Verify that the high flow valve opens, if equipped. Inspect all plumbing for leaks at this time.
- 5 Turn the pump handle off. Open the nozzle. No fuel must be dispensed at this time.
- 6 Verify if the correct quantity was recorded by the fuel management system, if available.
- 7 If applicable, repeat steps 2 to 6 for Side 2.
- 8 Run the unit through all standard calibration procedures.

## POST Start-up Tests

### Voltage

The incoming voltage to the pump and remote dispenser must be inspected and any reading that is not within 10% of the rated voltage must be corrected before the testing is continued. When dealing with suction pumps, it is a good practice to take voltage readings while the suction pump is operating on bypass and also while making a delivery. Any voltage drop in excess of 10% during either of these operating states must be considered a low voltage condition. Corrective action must be taken to insure an adequate power supply to the pump.

### Tightness

After determining that the pump is operating satisfactorily and the system is fully primed, inspect the pump and piping to ensure that all connections are tight. In the case of a remote dispenser, follow the submersible pump manufacturer’s instructions to ensure the system for tightness. We recommend that the tank and the piping must not be covered until this test is complete.

### Belts (Suction Pumps Only)

Since belts stretch slightly during the first few minutes of operation, inspect the belt tension after completing the operational test. A properly tightened belt permits twisting the belt 180 degrees midway between the motor and pump pulleys.

## Safety Information

For safety information before operating pumps/dispensers, refer to “[Important Safety Information](#)” on [page 2-1](#).

### **WARNING**

Running vehicles can generate sparks, which could ignite fuel.

Running vehicles could create a safety hazard, such as a fire or an explosion.

Never dispense fuel into a vehicle with its motor running.

## Preparing for Servicing the Pumps/Dispensers

This section provides instructions for preparing your site for servicing, done by a Gasboy-trained ASC.

### **WARNING**

The pump/dispenser contains pressurized flammable fuel and lethal voltages.

Servicing a Gasboy unit incorrectly could result in severe injury or death.

Do not attempt to service Gasboy pump/dispenser yourself and do not allow untrained personnel to service Gasboy pumps/dispensers. Only Gasboy-trained ASCs must service a Gasboy unit.

### **WARNING**

Unapproved modifications could result in hazardous conditions.

Making unapproved modifications could result in improper equipment operation and violation of state and local codes and could also create a hazardous condition, such as fire, explosion, or electrical shock.

Do not make unapproved modifications to Gasboy equipment. Consult your ASC, distributor, or Gasboy for approved modifications and kits.

## Call Gasboy First

Before calling an ASC, call the Gasboy Help Desk at 1-800-444-5529. The Help Desk may be able to resolve the issue for you. If you have a service maintenance contract with Gasboy, you may contact the Help Desk first.

## Service Preparation

Use a Gasboy-trained ASC to efficiently service and maintain your Gasboy pumps/dispensers. Gasboy trains and certifies ASCs to service and maintain Gasboy pumps/dispensers in a safe manner.

### Before Calling for Service

Perform the following tasks before you call for service:

- Obtain complete information from the station personnel about the problem.
- Confirm that the tank has fuel.
- Confirm that the power, pump lights, and circuit breakers are on.
- Record Error Codes that may exist on the Main Display (Electronic Units only).
- Ensure that you know the unit model number and serial number. For details, refer to [“Understanding Date Codes”](#) on [page 3-6](#).

### Description of Problem

Provide the ASC with a complete problem description including all symptoms. Give the serviceman complete and accurate information. This ensures faster repairs and keeps downtime costs to a minimum.

### Warranty Service

All warranty service must be performed by an ASC. Failure to use an ASC to perform warranty service could result in loss of warranty coverage.

## Replacement Parts

Use only genuine Gasboy replacement parts and retrofit kits on your pump/dispenser.

### WARNING

Non-Gasboy replacement parts may create safety hazards and violate local regulations. Non-Gasboy replacement parts could also affect the pump/dispenser's performance, reliability, and warranty.

Use of non-Gasboy replacement parts could create a hazardous condition, such as fire, explosion, or electrical shock.

Only use Gasboy replacement parts and retrofit kits.

## Specialized Training

For safety reasons, do not attempt to service Gasboy pump/dispenser yourself unless you have been trained and certified by Gasboy or an authorized Gasboy certified trainer.

### **WARNING**

The pump/dispenser contains pressurized flammable fuel and lethal voltages.

Servicing a Gasboy unit incorrectly could result in severe injury or death.

Do *not* attempt to service Gasboy pump/dispenser yourself and do not allow untrained personnel to service Gasboy pumps/dispensers. Only Gasboy-trained ASCs must service a Gasboy unit.

To receive specialized training for servicing Gasboy pumps/dispensers, contact a Gasboy-trained contractor or distributor. Training may be available locally at various regional centers.

Contractors and distributors may charge a nominal training fee. For more information, contact your nearest distributor. To locate a distributor near you, visit [www.gasboy.com](http://www.gasboy.com) and click the **Locate Distributor** link.

## Preventive Maintenance

Gasboy pumps and remote dispensers are designed for many years of uninterrupted service. However, certain dispenser or pump parts experience normal wear and therefore require periodic inspections. For example, detecting fuel leaks that may occur, belt tension and belt condition, lubrication, and strainer cleanliness are all important to maintain safe and efficient unit operation. Therefore, to avoid annoying pump shut downs, a periodic preventive maintenance inspection plan must be established and followed.

Procedures requiring leak repair, shear valve maintenance, and disassembly of portions of the pump/remote dispenser must be performed by an ASC.

### **WARNING**

To avoid electrical shock or hazard of an explosion or fire, when servicing remote pump/dispenser:

- Turn off and lock out all power to the pump/remote dispenser (in submersible pump applications turn off and lock out power to the submersible pump and any other remote dispensers which use that submersible pump. AC power can feed back into a shut-off dispenser when remote dispensers share a common submersible pump or starter relay).
- Turn off and lock out all power to the remote dispenser and submerged pumps at the master panel and close and test any impact valve before performing any maintenance or service to the remote dispenser, including changing any fuel filters or strainers.
- Block island so no vehicles can pull up to the remote dispenser when the dispense is being worked on.

**CAUTION**

Moisture from rain can damage the internal components of a pump/dispenser.

Internal components that are exposed to moisture may not operate correctly.

Do *not* open the electronics cabinet to perform any other tasks when it is raining.

 **WARNING**

High alcohol percentage fuels such as E85 or fluids such as DEF may be incompatible with certain plumbing materials and hydraulic components.

Use of incompatible materials or components with E85 can result in leaks. For E85, unexpected failures of components may also occur resulting in fire or explosion or environmental damage.

When dispensing alternative fuels such as E85 or fluids such as DEF, verify with the manufacturer if the material of all plumbing components are compatible with the fuel (E85) or fluid being dispensed.

## Maintenance of Vendor Supplied Parts

Certain parts of the dispenser/pump are produced by vendors for Gasboy (hoses, nozzles, and so on) and as such may have documentation separate from that which Gasboy supplies. In such cases, it is required to consult the vendor documentation for service intervals and any adjustments that is required for your dispenser/pump.

### Use Authorized Parts

The use of unauthorized parts can:

- Void your warranty.
- Cause the loss of continuity of the Underwriters Label on the pump.
- Cause inefficient operation.
- Possibly cause an operational hazard.

Always use new gaskets and seals when servicing or rebuilding Gasboy equipment.

## Performing Inspections

This section provides instructions for scheduling two types of maintenance inspections:

- General inspections
- Component inspections

## Safety Warnings

Follow all safety precautions to prevent injury when inspecting a pump/dispenser at the islands.

### WARNING

You are performing inspections and maintenance in a potentially dangerous environment of flammable fuels/vapors and high voltage.

Fire, explosion, or electrical shock could result in severe injury or death if you do not follow safe procedures.

Read and obey all safety precautions in this manual to prevent potential injury or death.

## General Inspections

Perform a general inspection of each pump/dispenser as follows:

- Each week to ensure that all pumps/dispensers are operating properly
- Whenever you receive a complaint about potential unit problems

As part of your general inspection, inspect all areas for signs of damage or sharp edges. Replace any missing or damaged warning labels. Gasboy also strongly recommends that an ASC inspects the equipment periodically, as outlined in the next subsection.

### WARNING

Leaking fuel can be ignited, causing a fire or explosion.

Fire, explosion, or electrical shock could result in severe injury or death if you continue to use damaged pumps/dispensers.

If you find any leaks or damage, stop using the pump/dispenser and contact your local ASC.

### WARNING

Personnel servicing a pump/dispenser can be injured if the pump/dispenser is not barricaded to all unauthorized personnel and vehicles.

If proper precautions are not taken, the person servicing the unit can be injured by a vehicle.

Before servicing a pump/dispenser evacuate all unauthorized persons and vehicles; then, use safety tape or cones as barricades.

## Component Inspections

To schedule component inspections, refer to “Preventive Maintenance Table” on page 3-48. The station owner must only inspect for problems. For safety reasons, several tasks in the “Preventive Maintenance Table” on page 3-48 including all repairs, must be performed only by an ASC. To determine if an ASC must perform a task, refer to “Who Performs the Inspection/Repair” on page 3-48.

### WARNING

The pump/dispenser contains pressurized flammable fuel and lethal voltages.

Servicing a Gasboy unit incorrectly could result in severe injury or death.

Do not attempt to service Gasboy pump/dispenser yourself and do not allow untrained personnel to service Gasboy pumps/dispensers. Only Gasboy-trained ASCs must service a Gasboy unit.

### WARNING

Leaking fuel can be ignited, causing a fire or explosion.

Fire, explosion, or electrical shock could result in severe injury or death if you continue to use damaged pumps/dispensers.

If you find any leak or damage, stop using the pump/dispenser and contact your local ASC.

### CAUTION

Improperly installed or maintained equipment can create a hazard.

Improperly installed or maintained equipment could cause a fire, explosion, or electrical shock.

For any component not supplied by Gasboy (for example, hoses and nozzles), consult and follow the installation and maintenance instructions provided by the manufacturer.

## Power Reset External Adjustment (Mechanical Units)

If the pump or remote dispenser unit fails to reset or shut-off properly, the reset motor must be adjusted. To adjust, proceed as follows:

- 1 Loosen the lock nut on the adjusting screw and back screw out until it stops.
- 2 Move the reset lever to the ON position.
- 3 Turn adjustment screw in until reset motor starts.
- 4 Advance adjustment screw an additional 1/2 to 3/4 turn. Hold screw in this position and tighten the lock nut.

- 5 Move the reset lever to the OFF position, and then back to the ON position to verify if the reset motor operates properly. The reset coupling must make one revolution and stop.

**Figure 3-26: Power Reset for Pump or Remote Dispenser Unit**

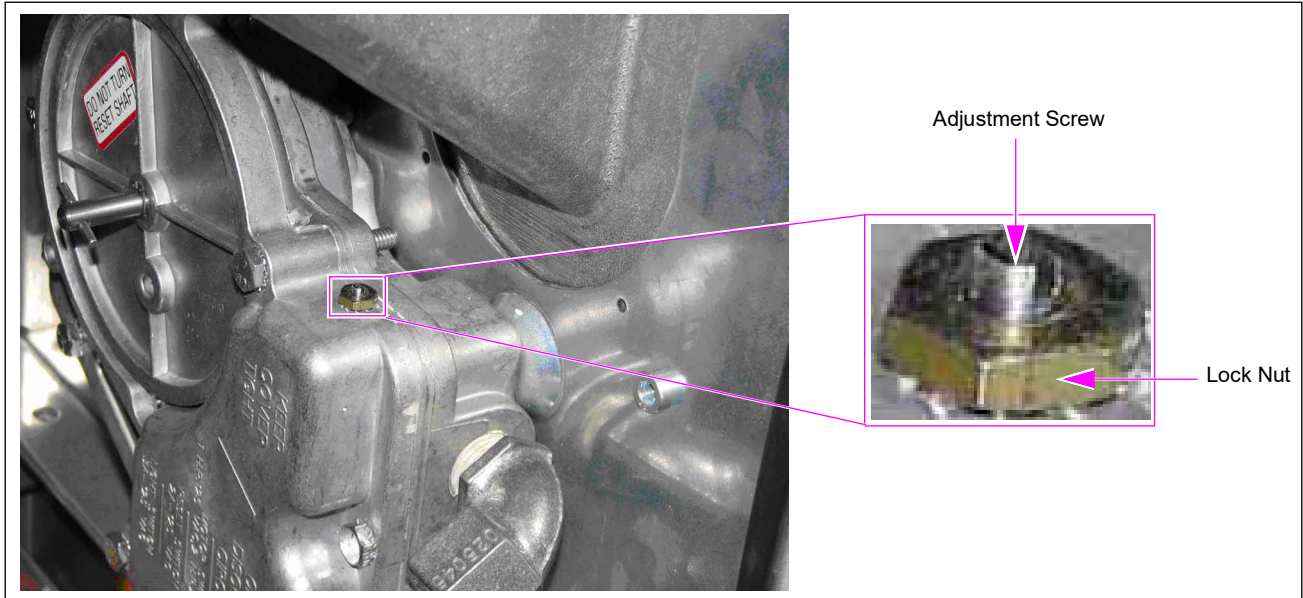

## Filter Strainer Replacement

If the unit is equipped with a strainer and filter, inspect and change it at regular intervals (refer to “[Filter change and strainer cleaning](#)” in “[Preventive Maintenance Table](#)” on [page 3-48](#)).

A dirty strainer or filter in a pump or remote dispenser causes a slower delivery rate. Refer to the accessories section of your parts manual to ensure that you replace the strainer if required and filter with one designed for your model. Always use a drip pan and absorbent material directly below the filter when removing the cartridge to prevent contamination of both the soil and the electrical components within the cabinet. This service must not be done by untrained individuals.

### **WARNING**

High alcohol percentage fuels such as E85 or fluids such as DEF may be incompatible with certain plumbing materials and hydraulic components.

Use of incompatible materials or components with E85 can result in leaks. For E85, unexpected failures of components may also occur resulting in fire or explosion or environmental damage.

When dispensing alternative fuels such as E85 or fluids such as DEF, verify with the manufacturer if the material of all plumbing components are compatible with the fuel (E85) or fluid being dispensed.

## Special Setup Required for Aircraft Fueling

### CAUTION

Aircraft require finely filtered fuel.

Improperly filtered fuel could cause the engine to fail.

Do not use Gasboy pumps/dispensers for direct fueling of aircraft without auxiliary filters, separators, and other equipment is required to ensure product purity.

## Adjusting the Belts (Suction Pumps Only)

With the proper care, belts give exceptionally good service. A loose belt not only cuts down dispensing speed, due to slipping, but also results in excessive wear. For more information, refer to “[Preventive Maintenance Table](#)” on [page 3-48](#). This service must not be done by untrained individuals.

## Preserve the Finish of Your Pumps

Nearly all gasoline pumps are installed outdoors where their surfaces are subjected to the weather conditions. As a result, it is required to give the finish a reasonable amount of care, if an attractive appearance is to be maintained.

The finish on Gasboy pump housings is a high-heat baked synthetic enamel, similar to that used on automobiles. The life of this finish can be lengthened several years if, at regular intervals, the painted surfaces are thoroughly cleaned with a high grade automobile polish and then protected with a coat of paste wax. Do not use abrasive cleaners or polish. Do not use high pressure spraying equipment. Do not use window cleaner with ammonia on the electronic display.

In order to retain the unmarked finish on stainless steel, occasional cleaning is required. In corrosive atmospheres, such as coastal areas, a more frequent cleaning schedule is required. Under ordinary conditions, washing with detergent or soap and water, followed by a clean water rinse, is sufficient. If hard water is used, the surface must be wiped dry with a soft clean cloth to prevent the formation of water spots. Marks or spots, such as grease, oily fingerprints, and smudges that resist soap and detergents, may have to be removed with a stronger cleaner.

### IMPORTANT INFORMATION

DO NOT use ordinary steel wool as iron particles may adhere to the surface and cause corrosion. Care must be taken in choosing a cleaner because any cleaning compounds or powders which contain abrasives can scratch a mill-rolled finish. Exercise care to ensure that any polishing is done with the lines in the steel, never across them. After cleaning, an application of paste wax is recommended to protect the surface and prolong the interval between cleaning.

## Preventive Maintenance Table

Components	Recommended Frequency	Recommended Maintenance	Who Performs the Inspection/Repair
Stainless Steel sheathing and lower doors	Monthly	For stains on stainless steel, use a cleaner specifically formulated for cleaning stainless steel. Gasboy recommends Bar Keepers Friend®. Ensure that you thoroughly rinse off all cleaner. Ensure that you do not spray water/cleaner directly at or into card readers, cash acceptors, or printer chutes.	Once every three months (in harsh environments, once a month)
Hoses, swivels	At least once a week or if a customer complaint arises	<ol style="list-style-type: none"> <li>1 Inspect each hose for leaks, abuse, and excessive wear.</li> </ol>	Owner—Inspect/Repair and test

**WARNING**

Leaking fuel can be ignited, causing a fire or explosion.

Fire, explosion, or electrical shock could result in severe injury or death if you continue to use damaged pumps/dispensers.

If you find any leaks or damage, stop using the pump/dispenser and contact your local ASC.

- 2 Inspect each hose, breakaway, whip hose, and vapor hose for the following wear or damage:
  - Bulges or Reinforcement showing
  - Cracks - Soft spots
  - Damage - Tears
  - Flattened spots - Weaknesses
  - Holes - wear through
- 3 Ensure that the vapor recovery hoses do not touch the ground when the nozzle is seated properly in the nozzle boot.
- 4 Consult the manufacturer for any additional inspections required.
- 5 If repair is required, call an ASC.

**WARNING**

The pump/dispenser contains pressurized flammable fuel and lethal voltages.

Servicing a Gasboy unit incorrectly could result in severe injury or death.

Do not attempt to service Gasboy pump/dispenser yourself and do not allow untrained personnel to service Gasboy pumps/dispensers. Only Gasboy-trained ASCs must service a Gasboy unit.

**WARNING**

Hoses of excessive length may create a trip hazard.

Serious injury could occur as a result of tripping over an excessive length hose.

Do not use excessive length hoses.

Components	Recommended Frequency	Recommended Maintenance	Who Performs the Inspection/Repair
Hose retrievers	Once a week or if a customer complaint arises	<ol style="list-style-type: none"> <li>1 Inspect hose retrievers for frayed or broken cables.</li> <li>2 Inspect hose retrievers for cables wrapped around hoses.</li> <li>3 If repair is required, call an ASC.</li> </ol>	Owner—Inspect/Repair and test

### **WARNING**

The pump/dispenser contains pressurized flammable fuel and lethal voltages.

Servicing a Gasboy unit incorrectly could result in severe injury or death.

Do not attempt to service Gasboy pump/dispenser yourself and do not allow untrained personnel to service Gasboy pumps/dispensers. Only Gasboy-trained ASCs must service a Gasboy unit.

### **WARNING**

Hoses that are not recoiled properly create a trip hazard.

Serious injury could occur as a result of tripping over an excessive length hose.

Repair or replace broken hose retrievers promptly.

Components	Recommended Frequency	Recommended Maintenance	Who Performs the Inspection/Repair
Nozzles and boot area	Once a week or as notified about a potential problem	1 Inspect nozzles for the following wear or damage: <ul style="list-style-type: none"> <li>• Damage</li> <li>• Leaks</li> <li>• Loose nozzle spouts</li> <li>• Missing parts, such as retainer springs and splash guards</li> </ul>	<ul style="list-style-type: none"> <li>• Owner—Inspect</li> <li>• ASC only—Repair and test</li> </ul>

** WARNING**

Leaking fuel can be ignited, causing a fire or explosion.

Fire, explosion, or electrical shock could result in severe injury or death if you continue to use damaged pumps/dispensers.

If you find any leak or damage, stop using the pump/dispenser and contact your local ASC.

- 2 Inspect vapor recovery boots (bellows) for proper seal and damage.
- 3 Consult the nozzle manufacturer for any additional required inspections.
- 4 If repair is required, call an ASC.

** WARNING**

The pump/dispenser contains pressurized flammable fuel and lethal voltages.

Servicing a Gasboy unit incorrectly could result in severe injury or death.

Do not attempt to service Gasboy pump/dispenser yourself and do not allow untrained personnel to service Gasboy pumps/dispensers. Only Gasboy-trained ASCs must service a Gasboy unit.

Components	Recommended Frequency	Recommended Maintenance	Who Performs the Inspection/Repair
Leaks, external	Once a week, or as notified about a potential leak	<ol style="list-style-type: none"> <li>Inspect the following for any signs of damage or leaks, such as cracks or cuts: <ul style="list-style-type: none"> <li>Couplings</li> <li>Hose outlet castings</li> <li>Swivels</li> </ul> </li> <li>Review all documentation provided by each component's manufacturer.</li> <li>If you find any leak, stop using the pump/dispenser and make arrangements to repair the leak.</li> </ol>	<ul style="list-style-type: none"> <li>Owner—Inspect</li> <li>ASC only—Repair and test</li> </ul>

### WARNING

Leaking fuel can be ignited, causing a fire or explosion.

Fire, explosion, or electrical shock could result in severe injury or death if you continue to use damaged pumps/dispensers.

If you find any leak or damage, stop using the pump/dispenser and contact your local ASC.



### WARNING

The pump/dispenser contains pressurized flammable fuel and lethal voltages.

Servicing a Gasboy unit incorrectly could result in severe injury or death.

Do not attempt to service Gasboy pump/dispenser yourself and do not allow untrained personnel to service Gasboy pumps/dispensers. Only Gasboy-trained ASCs must service a Gasboy unit.

Displays (Electro/Mechanical Units)	Once a week	<ol style="list-style-type: none"> <li>Inspect displays for proper reading of all digits.</li> <li>Verify that displays are properly backlit.</li> </ol>	<ul style="list-style-type: none"> <li>Owner—Inspect</li> <li>ASC Repair and test</li> </ul>
--	-------------	--	--

Components	Recommended Frequency	Recommended Maintenance	Who Performs the Inspection/Repair
Breakaways	Once a week or after drive-offs	<ol style="list-style-type: none"> <li>1 Inspect breakaways for secure connection to hose and for any leaks.</li>   <li>2 For units with hose retrievers, position the breakaway coupling between the retriever connection to the hose and the nozzle. The breakaway whip hose must be attached to the nozzle.</li> <li>3 Consult the breakaway manufacturer for any additional required inspections.</li> <li>4 If repair is required, call an ASC.</li> </ol>	<ul style="list-style-type: none"> <li>• Owner—Inspect</li> <li>• ASC only—Repair and test</li> </ul>
<p><i>Note: Not all breakaways are reusable after separation. Follow manufacturer directions for inspection and resetting for inspection and resetting adjustable types.</i></p>			
<div style="background-color: black; color: white; padding: 5px;"><b> WARNING</b></div> <p>Leaking fuel can be ignited, causing a fire or explosion.</p> <p>Fire, explosion, or electrical shock could result in severe injury or death if you continue to use damaged pumps/dispensers.</p> <p>If you find any leak or damage, stop using the pump/dispenser and contact your local ASC.</p>			
<div style="background-color: black; color: white; padding: 5px;"><b> WARNING</b></div> <p>The pump/dispenser contains pressurized flammable fuel and lethal voltages.</p> <p>Servicing a Gasboy unit incorrectly could result in severe injury or death.</p> <p>Do not attempt to service Gasboy pump/dispenser yourself and do not allow untrained personnel to service Gasboy pumps/dispensers. Only Gasboy-trained ASCs must service a Gasboy unit.</p>			
Warning tags and operating instructions	Once a week	Inspect for and replace all missing, damaged, or unreadable warning tags or operating instructions.	<ul style="list-style-type: none"> <li>• Owner—Inspect</li> <li>• Owner or ASC—Replace</li> </ul>
Hose continuity	Once a month	Verify that the hose continuity (including breakaway whip hose) complies with the hose manufacturer’s requirements.	<ul style="list-style-type: none"> <li>• Owner—Inspect</li> <li>• ASC only—Repair</li> </ul>

** WARNING**

The pump/dispenser contains pressurized flammable fuel and lethal voltages.

Servicing a Gasboy unit incorrectly could result in severe injury or death.

Do not attempt to service Gasboy pump/dispenser yourself and do not allow untrained personnel to service Gasboy pumps/dispensers. Only Gasboy-trained ASCs must service a Gasboy unit.

Components	Recommended Frequency	Recommended Maintenance	Who Performs the Inspection/Repair
Meters, Valves	Once a month, after drive-offs, or as notified about a potential leak	<ol style="list-style-type: none"> <li>1 Whenever possible, Gasboy recommends removing power to the unit before performing these inspections.</li> <li>2 Block off the pump/dispenser to prevent customers from operating the pump/dispenser during inspection.</li> <li>3 Remove the lower panels slowly and carefully.</li> <li>4 Inspect all hydraulic connections and seals, including the following: <ul style="list-style-type: none"> <li>• Meters</li> <li>• Valves</li> </ul> </li> <li>5 If wetness or dripping fuel is found, stop using the pump/dispenser and make arrangements for repairing the leak. <i>Note: Some staining of parts around seals is normal and does not necessarily indicate a leak.</i></li> <li>6 Monitor repaired components closely.</li> </ol>	<ul style="list-style-type: none"> <li>• Owner—Inspect</li> <li>• ASC only—Repair and test</li> </ul>

### WARNING

Gasoline or other fuels can damage the eyes.

Fuel sprayed into the eye can burn eye tissue.

To prevent potential injury, wear eye protection when performing these inspections.

### WARNING

Self-contained pumps have a pinch point between the belts and the pulleys.

Severe injury could occur if part of the body is pulled into the pinch point.

To prevent injury when inspecting self-contained units, do not place your hands near the belts, pulleys, or motors. Turn off the power before servicing the unit. Do not operate the unit with the door removed.

### WARNING

Leaking fuel can be ignited, causing a fire or explosion.

Fire, explosion, or electrical shock could result in severe injury or death if you continue to use damaged pumps/dispensers.

If you find any leak or damage, stop using the pump/dispenser and contact your local ASC.

### WARNING

The pump/dispenser contains pressurized flammable fuel and lethal voltages.

Servicing a Gasboy unit incorrectly could result in severe injury or death.

Do not attempt to service Gasboy pump/dispenser yourself and do not allow untrained personnel to service Gasboy pumps/dispensers. Only Gasboy-trained ASCs must service a Gasboy unit.

Components	Recommended Frequency	Recommended Maintenance	Who Performs the Inspection/Repair
Filter change and strainer cleaning	New Installations— After 50,000 gallons (200,000 liters), or after one month  After first filter change—Every 300,000 gallons (1.0 million liters), every six months, or when fuel delivery rate significantly slows.	Replace filters, and clean strainers regularly. An ASC must perform these tasks.	ASC

** WARNING**

The pump/dispenser contains pressurized flammable fuel and lethal voltages.

Servicing a Gasboy unit incorrectly could result in severe injury or death.

Do not attempt to service Gasboy pump/dispenser yourself and do not allow untrained personnel to service Gasboy pumps/dispensers. Only Gasboy-trained ASCs must service a Gasboy unit.



Inspect and lubricate shear valves	Every six months	To inspect valve operation, perform the following tasks. If you are not sure which device is the shear valve, have the ASC inspect and lubricate this device for you. <i>Note: Shear valves are typically only used on dispensers. If you have pumps, consult your installer to determine if they were installed on your pump.</i> <ol style="list-style-type: none"> <li>1 Trip the valve. For details, refer to <a href="#">"Shear Valve"</a> on <a href="#">page 3-27</a>.</li> <li>2 Authorize the hose at the console, if required.</li> <li>3 Lift the operating handle.</li> <li>4 Place the discharge nozzle in an approved container.</li> <li>5 Squeeze the nozzle operating lever. If flow continues after several seconds, the valve is defective.</li> <li>6 Place a few drops of SAE10 oil on valve body shaft.</li> <li>7 Open and close valve with a wrench several times.</li> <li>8 Place valve back in service.</li> <li>9 If repair is required, call an ASC.</li> </ol>	<ul style="list-style-type: none"> <li>• Owner—Inspect</li> <li>• ASC only—Repair and test</li> </ul>
------------------------------------	------------------	---	---

** WARNING**

The pump/dispenser contains pressurized flammable fuel and lethal voltages.

Servicing a Gasboy unit incorrectly could result in severe injury or death.

Do not attempt to service Gasboy pump/dispenser yourself and do not allow untrained personnel to service Gasboy pumps/dispensers. Only Gasboy-trained ASCs must service a Gasboy unit.

Components	Recommended Frequency	Recommended Maintenance	Who Performs the Inspection/Repair
Pump pulleys, belts, and belt tension	Every six months or if a squealing noise occurs during unit operation	<ol style="list-style-type: none"> <li>1 Remove power to the unit.</li> </ol>	<ul style="list-style-type: none"> <li>• Owner—Inspect</li> <li>• ASC only—Repair and test</li> </ul>
<div style="background-color: black; color: white; padding: 5px;"><b> WARNING</b></div> <div style="border: 1px solid black; padding: 10px; margin-top: 5px;"> <p>Failure to remove power to the unit before servicing it could result in injury.</p> <p>Failure to remove power could create a hazard, such as electrical shock.</p> <p>Remove power to the unit before servicing it.</p> </div>			
<div style="background-color: black; color: white; padding: 5px;"><b> WARNING</b></div> <div style="border: 1px solid black; padding: 10px; margin-top: 5px;"> <p>Self-contained pumps have a pinch point between the belts and the pulleys.</p> <p>Severe injury could occur if part of the body is pulled into the pinch point.</p> <p>To prevent injury when inspecting self-contained units, do not place your hands near the belts, pulleys, or motors. Turn off the power before servicing the unit. Do not operate the unit with the door removed.</p> </div>			
<ol style="list-style-type: none"> <li>2 Inspect belts for fraying/cracks.</li> <li>3 Inspect pulleys for excessive wear in grooves and excessive bearing play.</li> </ol>			
Tank	Every six months	<ol style="list-style-type: none"> <li>1 Monitor water levels in tank with electronic tank monitor or water detection pasted on tank measuring stick.</li> <li>2 If repair is required, call an ASC.</li> </ol>	Owner - Inspect

** WARNING**

The pump/dispenser contains pressurized flammable fuel and lethal voltages.

Servicing a Gasboy unit incorrectly could result in severe injury or death.

Do not attempt to service Gasboy pump/dispenser yourself and do not allow untrained personnel to service Gasboy pumps/dispensers. Only Gasboy-trained ASCs must service a Gasboy unit.

Components	Recommended Frequency	Recommended Maintenance	Who Performs the Inspection/Repair
Nozzle hooks and shafts	Every six months	<ol style="list-style-type: none"> <li>1 Lubricate with silicone spray, if required.</li> <li>2 Inspect for damage.</li> <li>3 Verify that the locking tab locator is not broken. (The locking tab locator helps hold the nozzle in the nozzle boot and enables the station owner to lock the nozzle boot with a clasp padlock).</li> <li>4 If repair is required, call an ASC.</li> </ol>	<ul style="list-style-type: none"> <li>• Owner: Inspect</li> <li>• ASC only: Repair and test</li> </ul>

** WARNING**

The pump/dispenser contains pressurized flammable fuel and lethal voltages.

Servicing a Gasboy unit incorrectly could result in severe injury or death.

Do not attempt to service Gasboy pump/dispenser yourself and do not allow untrained personnel to service Gasboy pumps/dispensers. Only Gasboy-trained ASCs must service a Gasboy unit.

Mechanical computers	Every six months	Lubricate well. See Veeder-Root® manuals for lubrication points.	ASC only
----------------------	------------------	--	----------

** WARNING**

The pump/dispenser contains pressurized flammable fuel and lethal voltages.

Servicing a Gasboy unit incorrectly could result in severe injury or death.

Do not attempt to service Gasboy pump/dispenser yourself and do not allow untrained personnel to service Gasboy pumps/dispensers. Only Gasboy-trained ASCs must service a Gasboy unit.

Door locks	Every six months or if door locks become difficult to open and close	Lubricate with a graphite lubricant or lock oil. Follow manufacturer's instructions. Do not over-lubricate. Use a rag to wipe any excess that may drip.	Owner
------------	--	---	-------

Water in Tank	After every fuel tank fill-up	Remove with a sump pump <ol style="list-style-type: none"> <li>1 Gasboy recommends removing power to the unit before performing these inspections and process.</li> <li>2 Block off the pump/dispenser to prevent customers from operating the pump/dispenser during procedure.</li> <li>3 Access and Insert sump pump into tank and draw off water.</li> </ol>	<ul style="list-style-type: none"> <li>• Owner: Inspect</li> <li>• ASC only: Repair and test</li> </ul>
---------------	-------------------------------	---	---

Components	Recommended Frequency	Recommended Maintenance	Who Performs the Inspection/Repair
Wax pump/dispenser	Every six months or once a month in harsh areas	Wax metal parts with high-grade, detergent-resistant, nonabrasive automobile wax. Do not wax textured surfaces.	Owner

- Adhere to the following guidelines for waxing the pumps/dispensers:
- Before waxing, clean the pumps/dispensers and touch up deep scratches on painted surfaces.
  - Wax painted surfaces with a high grade, long lasting, detergent resistant, non-abrasive automobile wax.

*Note: Gasboy recommends more frequent waxing for pumps/dispensers located in salty or corrosive environments, such as near the ocean or near pollution sources.*

### CAUTION

Textured surfaces of Gasboy pumps/dispensers can become damaged if waxed.

Waxing the textured surfaces can damage the units, adversely affecting the appearance of the units.

Do not wax textured surfaces.

### CAUTION

The main and PPU displays of Gasboy pumps/dispensers can become difficult to read if waxed.

Waxing the main and PPU displays may impede a customer's ability to read the display because the display may appear hazy.

Do not wax the displays on the pump/dispenser.

Components	Recommended Frequency	Recommended Maintenance	Who Performs the Inspection/Repair
Wash pump/dispenser	As required	Clean with automobile cleaning products. Clean plastic surfaces and poly carbonate graphics with water and mild detergent. Do not wash with a hose. Do not use window cleaner with Ammonia on Electronic display windows.	Owner
<p><i>Note: Gasboy recommends more frequent cleaning for pumps/dispensers located in salty or corrosive environments, such as near the ocean or near pollution sources.</i></p>		<p>Adhere to the following guidelines for washing the pumps/dispensers:</p> <ul style="list-style-type: none"> <li>• Clean and protect your equipment with automobile cleaning and protection products.</li> <li>• Clean plastic surfaces and poly carbonate graphics with a solution of water and mild detergent.</li> <li>• Use a soft cloth, paper towel, or sponge to clean displays separately. Window cleaners are preferred.</li> <li>• Wash pumps/dispensers by hand, or use a hose nozzle set to a fine gentle spray.</li> </ul>	
<div style="background-color: black; color: white; padding: 5px;"><b>CAUTION</b></div> <p>Moisture can damage the internal components of a pump/dispenser.</p> <p>Internal components exposed to moisture may not operate correctly.</p> <p>Do not use a pressure washer to clean the pumps/dispensers.</p>			
<div style="background-color: black; color: white; padding: 5px;"><b>CAUTION</b></div> <p>The exterior surface of Gasboy pumps/dispensers can become damaged if cleaned with harsh cleaners.</p> <p>Harsh cleaners can damage the units, adversely affecting the appearance of the units.</p> <p>Do not use solvents, harsh detergents, degreasers, steel wool, abrasive cleaners, or petroleum-based solvents on the pumps/dispensers.</p>			
Display windows	As required	Clean with nonabrasive cloth or paper towel with commercial glass cleaner. Do not use window cleaner with Ammonia. Do not wax or use any abrasive cleaners or fuels.	Owner

---

# Glossary

---

## A

### **Access Door**

Locked Access door on pump/dispenser.

### **Authorized Service Contractor (ASC)**

A Gasboy-trained and authorized service contractor.

## B

### **Boot Area**

The part of the pump/dispenser where the nozzle is stored.

### **Breakaway**

Device attached to the hoses on pump/dispensers that detaches if a customer drives off with the nozzle still attached to the vehicle; the device protects against gasoline being spilled and a resulting fire, and it minimizes damage to the pump/dispensers in the event of a drive off and stops fuel flow through the separated hose.

## C

### **Component Inspections**

Periodic inspections by the station manager of various pump/dispenser components; the station manager must look for signs of damage and wear for each component.

*Note: For a list of components and the recommended frequency of inspection, refer to “[Component Inspections](#)” on page 3-45.*

### **Couplings**

Plumbing used to join ordinary pipes or hoses together; see also “[Breakaway](#)”.

### **Cradle**

Refer to “[Boot Area](#)”.

## D

### **Date Code**

Two-letter code that is printed on the pump/dispenser before the serial number; shows the month and year of manufacture.

### **DEF**

Diesel Exhaust Fluid. A clear, colorless, non-toxic, non-flammable, non-combustible liquid. It is made up of 32.5% urea with the balance distilled or de-ionized water. Urea and water are completely miscible and do not separate in storage. DEF is mildly corrosive.

### **Dispenser**

A device that uses an STP in the storage tank to move fuel from the storage tank.

### **Drive Offs**

Situations where customers forget to remove the nozzles from the tanks in their vehicles and drive away from the pump/dispenser; the hose detaches from the pump/dispenser at the breakaway.

## **E**

### **Electrical Junction Box**

Refer to [“Junction Box”](#) on [Glossary-3](#).

### **E85**

E85 is an alcohol fuel mixture that contains up to 85% denatured fuel ethanol, and gasoline or other hydrocarbon by volume.

## **G**

### **General Inspections**

Weekly inspections by the station manager of all of the pumps/dispensers on the site; the station manager must ensure that all pumps/dispensers are operating properly, that no warning labels are missing, and that there is no evidence of damage or sharp edges.

### **Grade**

Quality of fuel, such as unleaded or premium.

### **Graphite Lubricant**

Type of lubricant used on the door locks of pumps/dispensers.

## **H**

### **Hose Outlet Castings**

Fuel discharge port on the pump/dispenser where the hose is attached to the unit.

### **Hose Retriever**

Device (option) at the pump/dispenser that retracts and pulls the hose close to the pump/dispenser after the customer has completed fueling.

### **Hydraulic Connections**

Any fuel-handling hardware where castings, hoses, and pipes are joined through threads, O-rings, or other seals.

## **I**

### **Inspections**

Refer to [“Component Inspections”](#) on [page 3-45](#) and [“General Inspections”](#) on [page 3-44](#).

**J****Junction Box**

The explosion-proof box on the pump/dispenser that contains the main electrical connections between the pump/dispenser and the main power and data source.

**L****Lock Oil**

Type of lubricant used on the door locks of pumps/dispensers.

**M****Meter**

Device in the pump/dispenser that measures fuel flow.

**Mode of Operation**

The method of functioning of the pump/dispensers.

**N****National Fire Protection Association (NFPA)**

An international nonprofit organization dedicated to protecting lives and property from the hazards of fire; publishes 280 recognized codes and standards, including the *National Electrical Code*.

**Nozzle**

On the pump/dispenser, the projecting part at the end of the hose that regulates and directs the flow of fuel.

**Nozzle Hook**

In the boot area on the pump/dispenser; place upon which the nozzle rests when the pump/dispenser is not in use.

**O****Occupational Safety and Health Association (OSHA)**

U.S. agency that develops and enforces regulations for the safety and health of workers engaged in interstate commerce.

**P****Price Per Unit (PPU)**

The price of each unit of gasoline dispensed.

**Pump**

A device that uses a self-contained pumping unit and motor to move fuel from the storage tank.

### **Pump Pulleys**

Ordinary pulley wheels used on self-contained suction pumps and motors.

## **S**

### **Seals**

Substances used to prevent seepage of gasoline or vapor from the pump/dispenser.

### **Shear Valves**

Device at the base of each pump/dispenser that shuts off the fuel flow in case of a vehicle impact or fire at the base of the pump/dispenser.

### **Side A**

Normally the side of the pump/dispenser with the electrical junction box (For front load units, Side A may be the side opposite to the junction box.).

### **Side B**

The side opposite to that of side A.

### **Silicone Grease**

Type of lubricant used on the nozzle hooks and shafts of pumps/dispensers.

### **Standalone Mode**

Authorization and payout occur at the pump.

### **Submersible Turbine Pump (STP)**

Submerged turbine pump in underground storage tank.

### **Swivels**

A fastening that permits the free turning of attached parts to the pump/dispenser.

## **V**

### **Volume Allocation**

The maximum amount of product the pump/dispenser will dispense.

# Index

---

## A

abbreviations 2  
accessories 10  
Acronym table 2  
actuator 13  
ASC 16  
AtlasX Fuel Systems 1

## C

Commercial 8  
Component inspections 59

## D

Date code 12  
Date codes 11  
DEF 3  
dual hose 10

## E

E85 dispensers 16  
Emergency 4  
Encore series  
    Diagram 7

## G

gallons 8  
General inspections 58  
Glossary 1  
ground tank 18

## H

Hazards and Actions 5  
hose lengths 18

## I

Inspections  
    Component 59  
    General 58

## J

Jumpers 23

## L

leak detection 18

## M

Maintenance 56  
Safety warnings 58

## O

Operating pumps/dispensers 20

## P

Parts  
    Replacing 55  
    Pipe Sealant 16  
    pivot 21  
    Preliminary Precautions 3  
    pump hydraulics 25

## R

readings 12  
remote-controlled 10  
Replacement parts 55  
Retail 8

## S

Safety Information 3  
Safety Symbols 3  
segment test 25  
Serial Number 12  
Preparing for 54  
Warranty 55  
Specialized training 56  
submersible 10  
submersible pump 24

## T

TopKAT 24  
totalizers 8  
Specialized 56  
trip hazard 19

## V

Visual identification 10

## W

Warning Words 3  
warranty 11  
Warranty service 55



© 2024 GASBOY  
7300 West Friendly Avenue · Post Office Box 22087  
Greensboro, North Carolina 27410  
Phone 1-800-444-5529 · <http://www.gasboy.com> · Printed in the U.S.A.  
MDE-5695B AtlasX Fuel Systems Owner's Manual · October 2024